

# INTERNATIONAL ENERGY JOURNAL

Volume 21, Special Issue 1A  
January 2021

**BANGABANDHU CHAIR SPECIAL ISSUE (VOLUME 2)**

**Energy, Disaster, Climate Change:  
Sustainability and Just Transitions in Bangladesh**

**Guest Editors:**

*Joyashree Roy, Sheikh Tawhidul Islam, and Indrajit Pal*

Published by the

**REGIONAL ENERGY RESOURCES INFORMATION CENTER**  
Asian Institute of Technology  
P.O. Box 4, Klong Luang, Pathumthani 12120, Thailand





পররাষ্ট্র মন্ত্রী  
FOREIGN MINISTER

بِسْمِ اللَّهِ الرَّحْمَنِ الرَّحِيمِ



GOVERNMENT OF THE  
PEOPLE'S REPUBLIC OF BANGLADESH  
DHAKA

I am happy to note that *Bangabandhu Chair* at the Asian Institute of Technology is going to publish the second volume of 'Bangabandhu Chair Special Issue of the International Energy Journal' a research journal, dedicated exclusively to the Sustainable Energy Development discourse of Bangladesh. The publication comes with a promise to make a significant contribution to Sustainable Energy Development in Bangladesh as well as her long term adaptation to climate change.



*Bangabandhu Chair* was first established at AIT, Bangkok in 2018 in honour of the Father of Nation of Bangladesh Bangabandhu Sheikh Mujibur Rahman with a view to broadening our regional and global outreach in public (energy) policy discourse and particularly dissemination of knowledge on cutting edge technology to the service of developing societies. Under the tutelage of this Chair, a doctoral level advanced technological research has been supported keeping in mind sustainable development goals and strategies for the benefits of our people and the global community as a whole.

I take this opportunity to thank government of the Kingdom of Thailand and the AIT for their continuous support to the *Bangabandhu Chair*. I hope the Bangabandhu Chair Professor Dr. Joyashree Roy will continue her efforts at the AIT in setting a trend for exchange of knowledge among the scholars from different parts of the region and beyond. She deserves our sincere appreciation for presenting extremely complex and technically demanding subjects in a lucid and reader friendly manner.

I wish the *Bangabandhu Chair* special edition of International Energy Journal-published in the Mujib Year (2020-2021) – a grand success.

  
(Dr. A. K. Abdul Momen, MP)

**International Energy Journal**  
Volume 21, Special Issue 3A, January 2021

**Bangabandhu Chair Special Issue (Volume 2)**  
**Energy, Disaster, Climate Change: Sustainability and Just Transitions in Bangladesh**

**GUEST EDITORS**

**Prof. Joyashree Roy**

Bangabandhu Chair Professor  
Sustainable Energy Transition Program  
Department of Energy, Environment and Climate Change  
School of Environment Resources and Development  
Asian Institute of Technology  
P.O. Box 4, Klong Luang, Pathumthani 12120, Thailand  
Professor of Economics, Jadavpur University, India (on lien)  
Email: [joyashree@ait.asia](mailto:joyashree@ait.asia)

**Prof. Sheikh Tawhidul Islam**

Professor, Department of Geography and Environment  
Director, Institute of Remote Sensing  
Jahangirnagar University, Bangladesh  
Email: [s.t.islam@juniv.edu](mailto:s.t.islam@juniv.edu)

**Dr. Indrajit Pal**

Assistant Professor and Chair, Disaster Preparedness, Mitigation and Management  
Department of Development and Sustainability  
School of Environment Resources and Development  
Asian Institute of Technology  
P.O. Box 4, Klong Luang, Pathumthani 12120, Thailand  
Email: [indrajit-pal@ait.ac.th](mailto:indrajit-pal@ait.ac.th)

# International Energy Journal

## Volume 21, Special Issue 1A, January 2021

### Bangabandhu Chair Special Issue (Volume 2) Energy, Disaster, Climate Change: Sustainability and Just Transitions in Bangladesh

#### CONTENTS

Implementation Framework for Sustainable Development: What Matters in the Context of Bangladesh.....	1
<i>Joyashree Roy, Sheikh Tawhidul Islam, and Indrajit Pal</i>	
Policy Paper on the Post Covid-19 Sustainable Energy Options for Power Generation in Bangladesh.....	9
<i>Sakib Bin Amin, Adib Ahmed, Abdul Mahidud Khan, and Farhan Khan</i>	
Utilization of Soft Energy: Approach to Eco-Development in Rural Bangladesh.....	21
<i>Md. Hafiz Iqbal and Md Masumur Rahaman</i>	
Small Windmill as Alternative Power Source for Bangladesh: a Feasibility Survey Under Wind Speed Scenarios .....	33
<i>Md. Anwarul Karim</i>	
Feasibility of Geoscience to Determine the Location of Micro-hydro Power Potential for Rural Areas.....	41
<i>Stevanus Nalendra Jati, Samuel R.O. Manik, Dewi Puspita Sari, and Dendy Adanta</i>	
Solution to Optimum Gas Well Operation Problem for Developing Countries.....	57
<i>Kamil K. Mamtiyev, Tarana A. Aliyeva, and Ulviyya Sh. Rzayeva</i>	
Thermodynamic Analysis of Biomass Gasification for Energy Sustainability in Bangladesh and Major Crop Producing Asian Countries.....	69
<i>Sampad Kumar Das and Prokash C. Roy</i>	
Does Biomass Energy Consumption Improve Human Development? Evidence from South Asian Countries.....	81
<i>Shamal C. Karmaker, Shahadat Hosan and Bidyut B. Saha</i>	
A Comparative Study of Microgrid Policies for Rural Electricity Transition between Bangladesh and Thailand.....	93
<i>Thongchai Meenual and Parnuwat Usapein</i>	
Carbon Footprint Reduction with the Adoption of the Electricity-Powered Vehicles.....	101
<i>Olumide A. Towoju</i>	

International Cereal Trade of Bangladesh: Implications for Virtual Land, Water, and GHG Emissions from Agriculture.....	107
<i>Parmeshwar Udmale, Indrajit Pal, Sylvia Szabo, and Malay Pramanik</i>	
Factors Affecting Small-Scale Fishers Adaptation toward the Impacts of Climate Change: Reflections from South Eastern Bangladeshi Fishers.....	119
<i>Edris Alam, Al-Ekram Elahee Hridoy, and Mohammad Naim</i>	
Gender Perspectives of Energy, Disaster Management and Climate Actions in Rural Bangladesh.....	133
<i>Anusree Ghosh and Tapas Ranjan Chakraborty</i>	
White Paper Top Ten Priorities: in Implementation of Low Carbon Sustainable Energy Development and Adaptation Framework to Reduce Disaster Impact in the Context of Bangladesh.....	143
<i>Joyashree Roy, Sheikh Tawhidul Islam, Indrajit Pal, and Hasan Mahmud</i>	



[www.ericjournal.ait.ac.th](http://www.ericjournal.ait.ac.th)

## Implementation Framework for Sustainable Development: What Matters in the Context of Bangladesh

Joyashree Roy<sup>\*+,1</sup>, Sheikh Tawhidul Islam<sup>^</sup>, and Indrajit Pal<sup>#</sup>

**Abstract** - COVID 19 recovery path, economic growth path and climate resilient path have much in common to help in building back better for Bangladesh which experienced multiple hazards due to hydro-meteorological disasters during the pandemic year. Changing the framework around this intersection of sustainable developmental actions can strengthen the productive base of the economy which can create momentum for the attainment of equitable human wellbeing for people of Bangladesh. For successful implementation of actions updated methods, community involvement and data are the most important elements.

### 1. INTRODUCTION

21st century economic growth agenda especially after COVID-19 pandemic need a better evolved framing compared to the preceding century. What should be the “changed framing” of growth agenda? Lesson learnt from COVID-19 is just not about one of its kind of a health-related disaster due to appearance and spread of an unknown virus. It reflects much deep-rooted implication of how human activities (Dutta 2020, Roy 2020a) are planned, managed, how societies are governed, how individuals, communities, businesses (Tarafder 2020), international trade, resource extraction and above all the two institutions: market and the state function, perform and are monitored through transparent accounting process or fall short of managing new challenges in the absence of a visionary approach.

Post industrial revolution society over past one century experienced unprecedented technological progress due to various scientific discoveries, understanding and innovation (Kar 2020a, 2020b). The market and the state as complementary institutions grew over time historically according to societal organizational dynamics, power structure and resource ownership to address resource allocation issues within the society (Roy 2020b). The resources which market and state manage for allocation has property right defined to either private ownership or state ownership. Despite all such technological and institutional marvels of the past century it is a reality that in this century we inherit an unequal world with wide gap in capability and opportunities and access to technologies (UN 2020). This century begins in a world with approximately seven

billion human souls where approximately 50% are excluded from access to all the basic needs for a dignified living. Majority of them live in South Asia, East Asia and Africa. Also, science is now clear and can say with high confidence that it is the state of the climate system, state of the local natural assets, health of the forest, state of wild biodiversity, water, air, ocean, rivers systems, coasts are going to determine the economic outcome of this century and consequent human wellbeing. But systems are interconnected. Through the feedback loop choices of development pattern made by economic activity sectors and nations will also determine the state of all these natural resources, state of the climate system and disaster intensity, cascades and frequency (Roy, Islam and Pal, 2020). A frequently asked question for the fast-developing economies of 21st century like Bangladesh is, economic development first or climate first? Based on current scientific discourse due to interconnectedness of systems, answer is both need to happen together, and it is possible to choose a development pathway which is climate friendly and disaster resilient as well. A development path that reduces inequity and over all carbon footprint of production and consumption practices is one of such examples (Roy *et al.*, 2018). But that can happen in multiple ways through individual country level actions or through mutually beneficial global cooperation. Such actions increase economic activities, creates jobs and do not worsen climate change. Nature based solutions such as, sparing the nature to do the regulatory services (Shah *et al.*, 2020), mangrove or other forest conservation, protecting coastal salt marshes, floodplains, sea grass, investment in managing soil quality, air quality, or choosing an economic activity that prevents greenhouse gas emissions, local air polluting emissions, reduces solid and liquid wastes are all climate friendly economic activities. All these preventive activities have much higher multi-dimensional human wellbeing impact compared to building a concrete embankment for flood defense.

\* Bangabandhu Chair Professor, School of Environment Resources and Development, Asian Institute of Technology, P.O. Box 4, Klong Luang, Pathumthani 12120, Thailand.

<sup>+</sup> Professor of Economics, Jadavpur University, India (on lien).

<sup>^</sup> Professor, Jahangirnagar University, Bangladesh.

<sup>#</sup> Disaster Preparedness, Mitigation and Management, Asian Institute of Technology, P.O. Box 4, Klong Luang, Pathumthani 12120, Thailand.

<sup>1</sup>  
E-mail: [joyashree@ait.asia](mailto:joyashree@ait.asia)

## 2. IMPLEMENTATION FRAMEWORK: FOR CLIMATE FRIENDLY, DISASTER RESILIENT, SUSTAINABLE DEVELOPMENT FOR ECONOMIC GROWTH

**Economic systems** narrowly managed through market and state led regulations are unable to cover all the wider impacts of many of the current economic activities happening worldwide. Both formal and informal human activities do generate jobs and livelihood for many people. According to Report on Labor Force Survey 2010, the informal employment in Bangladesh is more than 85%. However, many informal activities might create impacts which go unregulated within current narrowly defined economic systems and can create larger social impact with cost burden on the society at large. One such example is air pollution and which is known as external effect (Dasgupta *et al.*, 2015, Dasgupta *et al.*, 2016) of private or government led economic activities within GDP framework (more discussion is there in [Volume 1 of this special issue](#)). COVID 19 can also be seen as one such external effect of wild animal trade and consumption. Wilderness is seen and mostly managed as an open access resource without exclusive property rights defined and thus have unintended tendency to get over exploited by the users. Climate change is an important example in this category and the consequent disasters are the wider negative impacts. MERS, SARS, EBOLA in the past were the precursors of current pandemic and alerts were on from scientific community. There has been discussion led by environmental economists, ecological economists for more than three decades to manage external effects of mainstream economic activities on environment and consequent feedback through implementation of broader framework of sustainable development. So, while polluting activities like coal extraction get accounted for in increasing GDP and economy's progress but adverse health impact of that or environmental impact remain unaccounted for. Pollution reducing activity, preventive health care actions do not get adequately captured by GDP but they do help in advancing human wellbeing and sustainable development. So, in post COVID 19 world what needs to change is framing the national economic progress indicators towards sustainable development.

In earlier volume 1 we presented the conceptual and operational framework. Here in this volume 2 (Figure 1) we present the components of implementation framework. For fast growing economies since majority of the energy infrastructure will be built in these next two/three decades (Mahmud and Roy, 2020) one driving force is implementing investment plans to accelerate the assessment of alternative resource potential of renewable resources using advanced scientific tools and methods. Methods of estimating costs and benefits quantitatively and qualitatively need to be advanced to be able to take into consideration the wider social and environmental costs and benefits and not just private costs and benefits. In terms of economic impact, a

disaster may be considered the opposite of an investment project. The three basic parameters of an investment project are the amount of the initial investment, the lifetime of the project and the flow of costs and benefits generated by the project over its lifetime. From an economic standpoint, project viability and disaster impacts can be assessed by comparing costs to benefits but going beyond standard techno-economic elements. Disasters cause damage to assets. It can be imagined as "disinvestments" which impacts the production of goods and services adversely. Inadequate methodologies give rise to uncertainties on climate change impact related and disaster related costs estimation (Hallegatte *et al.*, 2010). What is important to make clear is how the economic system can react to shocks from changing climate and disasters. How, preventive actions can help avoid, reduce shocks, disasters and resultant costs. But, this needs better understanding of how markets and non-market institutions function outside equilibrium, and of how various actors/economic agents behave under situations of high uncertainty. Opportunity costs and externalities that affect the wellbeing of society, non-market valuation methods become important tools for assessment. The boundary of externality/wider impact can be very different depending on the nature of disaster. It can be on neighbourhood community, national and/or international. The natural and anthropogenic hazards may lead to disasters, which might cause short and long term impacts on social and economic development of the country (Rahman *et al.*, 2020). Disaster cost estimation are not only to arrive at compensation, relief or insurance purposes but also for making choice among alternative recovery projects or prior preventive actions. For designing any policy or a governance programme, the functional need has to be translated into a functional requirement, a detailed quantitative and operational statement (Pal and Bhatia, 2017). To make it happen, experiential knowledge and a deeper understanding of the domain plays an essential role in guiding our search for plausible design alternatives (Pal *et al.*, 2017).

## 3. IMPLEMENTATION FRAMEWORK: FOR NEW INSTITUTIONS, GOVERNANCE AND ROLE OF COMMUNITY

Governments can enhance preventive action which can be cost effective than costly and sometimes uncertain "cure through relief" approach which needs huge resource mobilization and quick spending. Preventive actions are mostly in Public service categories so governments have an important role to play. Vulnerability to disasters is embedded in a complex system of societal structures and processes. Resilience to disasters is driven by a combination of social, economic, environmental, institutional, and other relevant processes that interact with and influence each other (Choudhury and Haqqe, 2016, Pal *et al.*, 2021). Djalante *et al.*, (2012) justify the use of the Hyogo Framework as a tool of analysis on the basis that (1) the Hyogo Framework is an internationally agreed



framework for disaster risk reduction to increase the resilience of nations and communities, and (2) the Hyogo Framework has been well received and well adopted in order to enable a comprehensive analysis on how countries implement various disaster risk reduction activities. However, that the Hyogo Framework initiated a strategic and systematic approach to building disaster resilience has rarely received critical analyses (Djalante *et al.*, 2012). Subsequently Sendai Framework for Disaster Risk Reduction (SFDRR) 2015- 2030 drive the national and subnational level risk governance and advocate the build back better for resilient communities with better adaptive capacity. Disaster impacts across the community grossly depends on their exposure, sensitivity and related vulnerability. Bottom-up approach considering community as central entity for spatial variations of the local level vulnerability as well as adaptive governance (Thanvisitthpon *et al.*, 2020).

#### 4. IMPLEMENTATION FRAMEWORK: ROLE OF EVIDENCE, INFORMATION AND DATA

**Insufficient data** give rise to uncertainties on total costs and benefits of climate change, unsustainable development and disaster. National statistics are usually blind to interaction between regular incremental cycles, crises and long disaster related shocks. Data sets run parallel and independently and makes cost estimates using standard macro data sets erroneous. The role of various systems and sub-systems/critical infrastructures e.g., electric system, water distribution, transportation have very important role to play in sustainable development through the supply-chain links. Interdependence of these systems/ structures play a very crucial role in terms of cost assessment and recovery of any economy.

Disaster shock led asset loss both at private and public level impacts long term recovery and sustainability. Asset loss and uncertainty creates impact on private decisions (households and company level) because of insufficient resources. The quality of response and recovery actions are primarily dependent on availability of context specific granular evidence base on multiple key indicators that determine total impact on people and their wellbeing and sustainable development indicators. So preventive actions, role of financial institutions and regulations can reduce indirect cost.

While globally accepted methods can be used but data types and needs usually vary by national circumstances and especially at community scale. They will be varying depending on socio-technical, economic and political agency of the individuals and social groups in any local contexts. However, digitalization can help in overcoming this agency problem by appropriate evidence and governance mechanism if these are built into the digital platform in inclusive way.

Globally, statistics show with resources allocation and technology, effective prevention can be planned to reduce disaster led loss and damage. In Bangladesh which is now on fast economic growth path costs of disaster impacts will rise significantly as a result of the greater concentration and value of societal activities

through asset creation. Reduction of loss and damage of people and to the nation as a whole and globally from disasters depend on quality of informed decision making for maximizing benefits from ‘response and recovery actions’.

To make information easily available and accessible and trustworthy there is urgent need to create this under public sector management:

- a) Maps of disasters at granular scale (neighbourhood/community scale) involving local institutional capacity. This granular database should be properly geocoded so that other relevant information could be added with it when necessary.
- b) Identification of hotspots through over lay of maps of multiple disasters.
- c) Maps of infrastructure and their risk levels to various disaster types.
- d) Maps of varying disaster impacted/exposed locations temporally to enable dynamic baseline determination possibility to help in planning long term recovery path.
- e) Map of protected coasts by type: nature based or manmade structures, embankment.
- f) Map of reliable and safe public transport system/routes to reduce loss and damage due to immobility of people e.g., to enable quick movement from unsafe areas to safer locations, home to work place and back.
- g) Map of agro-ecological systems based on contemporary data on soils, hydro-meteorological parameters, tidal amplitude and influence (especially for coastal resources).
- h) High spatial resolution terrain models based on accurate land elevation data so that locational attributes are adequately registered.
- i) High resolution demographic and health related data.
- j) Provisions for data sharing among the agencies should be made so that data-driven, effective decisions could be made.
- k) State of the art data, methods and techniques such as geospatial data and techniques (*i.e.* GIS, optical and radar remote sensing, LiDAR, GPS *etc.*) should be used for updating existing data and to generate new data where necessary.

Government of Bangladesh has an initial institutional arrangement to get information and estimate disaster loss and damage for different sectors. In this vertically connected governance structure through bottom up process, local government representatives and government officials use a prescribed form (‘D’ form and ‘SOS’ form) to collect information related to financial loss, number of affected households, challenges faced by different communities *etc.* In addition, other agencies like Bangladesh Bureau of Statistics (BBS) has taken initiatives to gather climate change induced disaster impacts data by undertaking a project titled ‘Generation of Disaster Related Statistics 2020: Climate Change and Natural Disaster



Perspectives'. Data are going to be generated from different disaster hot-spots every year by using mobile phone enabled smart data collection tool. BBS is also going to prepare four disaster and climate change focused reports under the framework of Bangladesh Environmental Statistics Framework (BESF 2016-2030). The major reports will be Report No. 3: Climate Change and Disaster Related Statistics (what is currently underway), Report No. 10: Disaster Risk Reduction Expenditure Accounts, Report No. 11: Climate Change and Natural Disaster Impacts Vulnerability Index and Report No. 13: Climate and Natural Disaster Induced Survey. In 2015, BBS conducted 'Impact of Climate Change on Human Life (ICCHL) Survey' and produced national level data on disaster impacts for the first time in Bangladesh. This data generation needs active involvement of local communities and stakeholders in a variety of ways to make the process inclusive.

Planning Commission conducted background studies (Report No. 11a and 11b) on disaster and climate change impacts to better understand the risks and vulnerabilities of the communities, which finally gave directives to formulate related targets for Seventh Five Year Plan (SFYP). The Eighth Five Year Plan (that is currently under preparation) has incorporated a number of DRR indicators in the scope of actions. The CPEIR (Climate Public Expenditure and Institutions Review) study undertaken by Planning Commission, CFF (Climate Fiscal Framework) published by Ministry of Finance are significant documents that provide valuable insights in understanding local level disaster risks and vulnerabilities. In parallel many other activities in allied fields were performed by different agencies, such as forest (e.g. REDD+, coastal afforestation project), water

resources (e.g. Blue Gold Project by BWDB and DAE, The Bangladesh Delta Plan 2100), and education (e.g. production of report on Climate Change Education for Sustainable Development, by the Ministry of Education through BANBEIS). These study reports are useful sources of information and conceptual construct to better understand disaster vulnerabilities and action plans in the context of Bangladesh. However, it is important to note that the existing set of data are not adequate to fulfil national need for policy implementation as mentioned in the sustainable development framework (Figure 1) and at the same time maintain international commitments on data reporting. For example, Bangladesh is currently absent in the UNDRR (United Nations Office for Disaster Risk Reduction) disaster impact database 'DesInventar' that does not go with longstanding good posture of Bangladesh in disaster management. Similarly Bangladesh is not fully ready for submitting information as per the guidelines provided by UN-FDES and SEEA, ESSAT *etc.*

This is the second volume of the **Bangabandhu Chair Special issue of *International Journal of Energy***. The first volume published in October 2020 aimed to present how the intellectuals and experts from within the country, region and from outside the region situate sustainable energy transition of Bangladesh in the context of national economic growth aspiration, responses to climate risk, disaster risk and dynamics of regional cooperation and global common good goal. In this special Volume 2 our aim is to carry forward the intellectual discourse and expert view which is very much relevant for the post COVID recovery phase of Bangladesh.

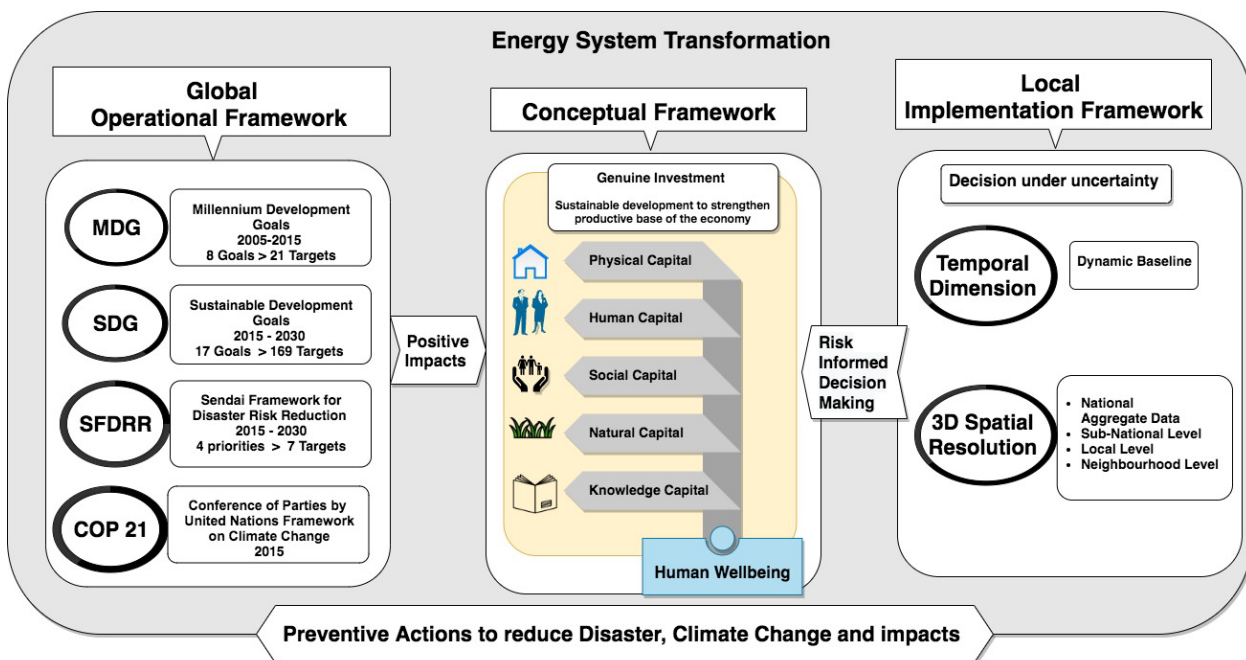

Fig. 1. Essential elements in contextualization for implementation of conceptual framework at various levels.

## 5. OUTLINE OF THE SPECIAL ISSUE: VOLUME 2

This Volume 2 examines the hypothesis that for contextualizing the conceptual and operational framework presented in volume 1 for successful implementation, methodological advancement in scientific assessment and analysis, data at various scales macro, meso and micro level are indispensable along with new institutional arrangements. Decision under uncertainty should be driven by appropriate methods, risk informed decision making process and this cannot happen improve unless data base is temporally maintained to help tracking progress and monitoring. Any decision over time need to depend on dynamic baseline as situations changes and a country progresses. So, in our 21<sup>st</sup> century conceptual framework in which core is sustainable development for human wellbeing with fairness/equity/justice we take a deeper look into the (1) various methodological advancements that help in modelling the resource potential better to diversify energy resource base going beyond traditional sources (2) find various means and capacities to collect and manage data base systematically with continuous updates and reviews by engaging national institutions and experts more closely both to reduce transaction cost and make use of internally sourced human and local knowledge capital (3) climate response strategy and sustainable development paths need to evolve covering mitigation and adaptation needs and very localized needs and especially in post pandemic period recovery path focusing especially on marginalized communities who are vulnerable. The articles compiled in this journal volume 2, through double blind peer review process addresses the following broad research questions:

- How can in post COVID recovery period Bangladesh economy expand its clean energy sources with application methodological advancement and by including people to share costs along with benefits?
- What is the scope of new major technological and social, economic innovations that can reduce carbon footprint and enhance adaptive capacity of various economic activities and social actors?
- How data generation and for a natural disaster exposed nation like Bangladesh how people, community and institutions interact to build resilience organically and which needs to be strengthened by scientific approaches?
- How is Bangladesh community at the margin coping with increasing disasters?

The original inspiration for this volume 2 comes from overwhelming response from researchers expressed through large number of submissions to our call for papers for a special issue. Idea of special issue germinated under the umbrella of Bangabandhu Chair endowment at AIT, Thailand by the Government of Bangladesh, Ministry of Foreign Affairs. The call for papers kept the basic thematic area under the endowment “Energy Sector Development in Bangladesh” and this journal’s core focus area of Energy.

Therefore, of all the articles that have been chosen and included in this volume bias is more towards energy. It is complemented by articles on climate change and disasters as they pose valid threats to sustainable development directly or indirectly. Content diversity has been managed in such a way that policy makers in Bangladesh can get useful tools and information to decide on a course of action with sustainability goal. Researchers on Bangladesh economy can get a status review of a broader interconnected branch of knowledge and identify the research gaps that can add value through future knowledge gap filling studies.

What basic areas Bangladesh need to critically examine in Post COVID-19 period under energy, climate change and disaster to continue on its sustainable development path are covered in this volume.

*Ahmed, Amin et al.* provide recommendations for post COVID-19 sustainable energy options for power generation in Bangladesh by revisiting the national policies in already in place. Methodology applied to do the analysis is state of the art Dynamic General Equilibrium (DGE) model for Bangladesh economy to capture the long-run consequences of the COVID-19 towards energy sector and economy. Such methods help in analysis of the sectoral changes within an economy caused by sudden shocks like the COVID 19. One major conclusion is that in the context of Bangladesh stimulus packages can build enough incentives to accelerate the private sectors and societal investment in renewable energy sector expansion.

The article by *Iqbal and Rahaman* take an approach where they consider ‘soft energy’ from a whole portfolio of renewable resources for rural households in Bangladesh like many other countries can come from biomass resources e.g., animal manure, crop residues, and kitchen and green wastes, solar radiation, water and wind and at the same time create jobs, meet modern energy demand, enhance wellbeing. They apply contingent valuation method and estimate truncated mean willingness-to-pay (WTP) to derive economic value that households in Bangladesh place so call soft energy as alternative sources.

Article by *Karim* presents how using a handmade small windmill local expert can investigate the voltage generation, current generation and power generation with respect to the wind speed in Bangladesh. According to the experimental results from small windmill and the survey reports on wind speed especially in coastal areas of the country suggest that the wind energy can be an alternative power source for Bangladesh.

Article by *Jati, Manik et al.*, makes an assessment and discusses about the importance of micro-hydro power plant (MHPP) as a viable solution to the electricity crisis in rural areas in Bangladesh. There is lack of implementation in the absence of enough information and the constraints for location review. The paper proposes and explains the process to determine the ideal location of micro-hydel power. The ideal source is field observations. Analytical hierarchy process (AHP) and geographical information systems (GIS) have been

used to determine the locations of micro-hydel power especially in the rural areas.

Article by *Mamtiyev, Aliyeva et al.*, present advancement in knowledge in methods for assessing optimum management of gas wells, especially relevant for Bangladesh. Resource conservation and efficiency in operation not only reduces cost of production and increase affordability but is a necessary condition for sustainable development.

Article by *Das and Roy* suggest a method to conduct thermodynamic analysis of biomass gasification for major crop producing Asian countries including Bangladesh. Biomass gasification is a very complex chemical process. They present a model with new kind of nonlinear stoichiometric coefficient for reaction rate constant, with no propagation of error to the next level of calculation. Such studies help in design and development of appropriate technologies to reduce environmental impacts from waste generated in agriculture and livestock sectors as well as provide affordable energy security through diversification of sources.

*Karmaker, Hosan and Saha* in their paper discussed about the effect of biomass energy consumption on the economy, environment and human development. It also talks about the reliance of large number of people on biomass energy usages in South Asia. The study also investigates whether biomass energy is contributing positively to human development or not. The study suggests that the usage of biomass energy has an adverse effect on human development in South Asian countries.

The article by *Meenual and Usapein* investigates rural electricity transition for Bangladesh and Thailand. Publicly accessible data related to microgrid policies in Bangladesh and Thailand have been collected and synthesized. The research represents comparative case study to offer a range of possible synergies across different dimensions and sectors to help transform energy sector in developing countries. The transition of rural electricity driven by microgrid policy in both the countries can be achieved by adopting new electricity market structure and regulation.

Article by *Towaju* emphasizes the importance of electric vehicles to provide increasing but clean mobility demand in developing countries following the growing global trend. But also demonstrates by estimating carbon footprint of electricity sector in various country contexts how single minded focus on electric vehicle cannot be a solution unless electricity generation sectors in many countries are made carbon free through renewable energy penetration.

The article by *Udmale, Pal et al.*, provide an insight on how in deciding on development pattern trade and domestic production can be thought of in an integrated way. An integrated management of water, energy, and low carbon can be one of the strategies to increase the cereal crop production and reduce GHG emissions from agriculture in Bangladesh. Energy use in agriculture, mainly for mechanization and irrigation purposes and there is potential to reduce GHG emissions from agriculture through various alternative actions and

also to meet INDCs. The methodology used for the study is virtual land and water flows through international cereal imports in Bangladesh.

The discussion by *Alam, Hridoy and Naim* addresses how fishing community on the ground perceive changes and their expectations concerning adaption action. Field level first hand source of information provide rich evidence base. Exploratory factor analysis and a binary logistic regression are used to derive results from empirical study. Despite lack of formal and institutional responses some of the impacted community adopt various coping mechanisms to continue fishing in the future.

*Ghosh and Chakraborty* show the intensity and frequency of natural disasters are increasing in Bangladesh. These are inducing challenges in energy sector in terms of availability, options, access with increased burden on women, especially in the rural Bangladesh. Participatory action research tools helped in bringing the gender perspectives of energy, disaster management and climate. The study concludes in favour of adaptive actions that address gender equity from very design of the projects.

Finally, as we mentioned in volume 1, an interesting aspect of this volume, from a sustainable development perspective, is that all of its lead authors, as well as a large majority of its other contributing authors, are from the region and from the country. While this author mix outcome has been mostly incidental, as it is outcome of an open call for papers widely circulated. It does demonstrate that there is a pool of highly qualified researchers and thinkers all around the world ready to commit time and effort to influence academic and policy discourses at the highest levels in the field of sustainable energy transformations, climate change and disaster risks in the context of Bangladesh. Unfortunately, despite the efforts of the editors it was not possible to keep all the submissions as 30% had to be rejected after double blind peer review process either due to divergence of the objectives from the thematic goal of this special issue or because they did not satisfy the scientific rigour and standard of the Journal.

Guest Editors and Bangabandhu chair researcher at AIT, synthesize the recommendations that emerge from the research studies and presents at the end in the form of a white paper which will be useful for decision makers in Bangladesh. Guest editors acknowledge with thanks cooperation from a large number of experts from various continents and institutions for their full cooperation, sometimes very tight timeline for review, taking the burden of reviewing more than one article, and sometime to review twice/thrice after resubmission in response to review comments. We acknowledge with thanks the voluntary time commitment of reviewers. Our sincere thanks to all the experts Professors/Dr/Ms/Mr. Abdul Salam, Amir Safari, Alak Pal, Anamika Barua, Anjal Prakash, Anupa Ghosh, B.B. Saha, Bikram Raha, Biswajit Thakur, Biswanath Roy, Byomkesh Talukdar, Chioma Onyige, Debalina Chakravarty, G.P. Ganapathy, Homam Nikpey Somehsaraei, Indrila Guha, J.G. Singh, Jonathan Rigg, Mani Nepal, Maria Figueroa, Md. Anwarul Abedin, Md. Rafiqul Islam, Md. Younus Mia,

Mohsen Assadi, Mofazzal Hossain, Oleg Lugovoy, Parimita Mohanty, Rajib Shaw, Ranjan Ganguli, Ranjana Chowdhury, S. Kumar, Sabuj Mandal, Sajjad Zohir, Sakib Bin Amin, Samir K. Saha, Sarmistha Das, Sasi Kottayil, Sebak K. Jana, Shyamasree Dasgupta, Soumyendra Kisore Datta, Souran Chatterjee, Suyash Jolly, Swarnendu Sen, Tejal Kanitkar, Tuhin Ghosh, V.R. Singh, Weerakorn Ongsakul, Yonariza, who helped us in the double blind review process. Also, we are extremely obliged to Editors of this Journal Prof. Kumar and Prof. Salam and the IEJ editorial support staff led by Kathrina for their excellent systematic, efficient, meticulous and prompt actions. Remaining errors are the responsibilities of the Guest Editors.

## REFERENCES

- [1] Choudhury M. and C.E. Haque, 2016. We are more scared of the power elites than the floods: Adaptive capacity and resilience of wetland community to flash flood disasters in Bangladesh. *International Journal of Disaster Risk Reduction* 19: 145-158.
- [2] Dasgupta P., Duraiappah A., Managi S., Barbier E., Collins R., Fraumeni B., Gundimeda H., Liu G., and Mumford K.J., 2015. How to measure sustainable progress. *Science* 350(6262): 748. DOI: 10.1126/science.350.6262.748.
- [3] Dutta S., 2020. Sustainability is the Sustainer of GAIA. Retrieved from the World Wide Web: <https://www.change framing.space/answering-the-burning-questions/sustainability-is-the-sustainer-of-gaia>.
- [4] Djalante R., Thomalla F., Sinapoy M., and Carnegie M., 2012. Building resilience to natural hazards in Indonesia: Progress and challenges in implementing the Hyogo Framework for Action. *Natural Hazards* 62: 779–803.
- [5] Hallegatte S. and V. Przyluski, 2010. The Economics of Natural Disasters: Concepts and Methods. The World Bank Sustainable Development Network Office of the Chief Economist December 2010. *Policy Research Working Paper* 5507.
- [6] Kar S., 2020a. Decoding Natural Laws: Scientific Journey through the Centuries. Retrieved from the World Wide Web: <https://www.change framing.space/answering-the-burning-questions/decoding-natural-laws-scientific-journey-through-the-centuries>.
- [7] Kar S., 2020b. Decoding Natural Laws: Scientific Journey Continues through the Centuries. Retrieved from the World Wide Web: <https://www.change framing.space/answering-the-burning-questions/decoding-natural-laws-scientific-journey-continues-through-the-centuries>.
- [8] Mahmud H. and J. Roy, 2020. Sustainable energy sector for fast growing economy like Bangladesh: How relevant are the past Asian precedents? *International Energy Journal* 20 (Special Issue 3A): 381-394.
- [9] Thanvisitthpon N., Shrestha S., Pal I., Ninsawat S., and Chaowiwat W., 2020. Assessment of flood adaptive capacity of urban areas in Thailand. *Environmental Impact Assessment Review* 81. doi:10.1016/j.eiar.2019.106363.
- [10] Pal I. and S. Bhatia, 2017. Disaster risk governance and city resilience in Asia-pacific region. *Science and Technology in Disaster Risk Reduction in Asia: Potentials and Challenges* 137-159. doi: 10.1016/B978-0-12-812711-7.00009-2.
- [11] Pal I., Ghosh T., and Ghosh C., 2017. Institutional framework and administrative systems for effective disaster risk governance – Perspectives of 2013 cyclone Phailin in India. *International Journal of Disaster Risk Reduction* 21: 350-359. doi:10.1016/j.ijdr.2017.01.002.
- [12] Pal I., Doydee P., Utarasakul T., Jaikaew P., Razak K.A.B., Fernandez G., Huang T., and Chen C.S., 2021. System approach for flood vulnerability and community resilience assessment at the local level: A case study of Sakon Nakhon province, Thailand. *Kasetsart Journal of Social Sciences* 42(1): 67–76. doi.org/10.34044/j.kjss.2021.42.1.xx.
- [13] Rahman K.F., Pal I., and Parven A., 2020. Energy security and disaster risk governance in energy sector of Bangladesh. *International Energy Journal* 20 (Special Issue 3A): 523 - 534.
- [14] Djalante R., Holley C., and Thomalla F., 2011. Adaptive governance and managing resilience to natural hazards. *International Journal of Disaster Risk Science* 2: 1–14. doi: 10.1007/s13753-011-0015-6.
- [15] Roy J., 2020a. Framing 21<sup>st</sup> Century problems with 21<sup>st</sup> century vision. Retrieved from the World Wide Web: <https://www.change framing.space/answering-the-burning-questions/falling-back-to-14th-century-to-solve-21st-century-problems>.
- [16] Roy J., 2020b. City of joy is confronted with the reality of two disasters. Retrieved from the World Wide Web: <https://www.change framing.space/answering-the-burning-questions/city-of-joy-is-confronted-with-the-reality-of-2-disasters>.
- [17] Roy J., Tschakert P., Waisman H., et al., 2018. Sustainable Development, Poverty Eradication and Reducing Inequalities. In: Global Warming of 1.5 °C. *An IPCC special report on the impacts of global warming of 1.5 °C above pre-industrial levels and related global greenhouse gas emission pathways, in the context of strengthening the global response to the threat of climate change, sustainable development, and efforts to eradicate poverty*. 445–538.
- [18] Roy J., Islam S.T., and Pal I., 2020. Energy, disaster, climate change: Sustainability and just transitions in Bangladesh. *International Energy Journal* 20 (Special Issue 3A): 373-380.
- [19] Shah M.A.R., Renaud F.G., Anderson C.C., Wild A., Domeneghetti A., Polderman A., Votsis A.,

- Pulvirenti B., Basu B., Thomson C., Panga D., Pouta E., Toth E., Pilla F., Sahani J., Ommer J., El Zohbi J., Munro K., Stefanopoulou M., Loupis M., Pangas N., Kumar P., Debele S., Preuschmann S., and Zixuan W., 2020. A review of hydro-meteorological hazard, vulnerability, and risk assessment frameworks and indicators in the context of nature-based solutions. *International Journal of Disaster Risk Reduction* 50: 101728. doi:10.1016/j.ijdr.2020.101728.
- [20] Tarafder S., 2020. The topsy-turvy commerce of the 21<sup>st</sup> century. Retrieved from the World Wide Web: <https://www.change framing.space/answering-the-burning-questions/the-topsy-turvy-commerce-of-the-21st-century>.
- [21] Udmale P., Pal I., Szabo S., Pramanik M., and Large A., 2020. Global food security in the context of COVID-19: A scenario-based exploratory analysis. *Progress in Disaster Science*. doi.org/10.1016/j.pdisas.2020.100120.
- [22] UN, 2020. World Social Report 2020. Inequality in a rapidly changing world. United Nation's Department of Social and Economic Affairs. Retrieved from the World Wide Web: <https://www.un.org/development/desa/dspd/wp-content/uploads/sites/22/2020/02/World-Social-Report2020-FullReport.pdf>.
- [23] [www.rericjournal.ait.ac.th/index.php/reric/issue/view/Volume%2020%2C%20Special%20Issue%203A%2C%20October%202020](http://www.rericjournal.ait.ac.th/index.php/reric/issue/view/Volume%2020%2C%20Special%20Issue%203A%2C%20October%202020).
- [24] Bangladesh Bureau of Statistics, Statistics Division, Ministry of Planning, Government of the People's Republic of Bangladesh. *Report on Labour Force Survey 2010*. <https://doi.org/10.1016/j.ijdr.2016.08.004>.





## Policy Paper on the Post Covid-19 Sustainable Energy Options for Power Generation in Bangladesh

[www.ericjournal.ait.ac.th](http://www.ericjournal.ait.ac.th)

Sakib Bin Amin\*<sup>1</sup>, Adib Ahmed<sup>+</sup>, Abdul Mahidud Khan<sup>+</sup> and Farhan Khan\*

**Abstract** – The central role of electricity in shaping the worldwide economy is broadly acknowledged in the energy literature. Having identified the then ongoing crisis of the electricity sector, the present Awami League government initiated restructuring the energy sector since 2009 to quicken the pace of the developmental activities. All these efforts resulted in landmark achievements in the Bangladesh energy sector, especially in increasing the electricity generation capacity. However, the global Covid-19 pandemic and its aftermath effects on the Bangladesh economy require a policy revision in Bangladesh's energy sector and electricity generation mix. To our knowledge, there is no study to analyse the adverse consequences of the Covid-19 in Bangladesh energy sector. By employing a SARIMA forecasting model, we reveal that electricity demand will remain less than the actual generation in the upcoming two years. Also, the DGE model finds that due to Covid-19, the economic growth rate will be around 4.5 percent in the long-run. We further simulate that the steady-state electricity demand and standard consumption values would fall by 8-10 percent and 6 percent, respectively. We recommend that a review of the power sector master plan is needed for future energy security and economic stability in Bangladesh.

**Keywords** – Bangladesh, Covid-19, dynamic general equilibrium model, SARIMA model, sustainable energy options.

### 1. INTRODUCTION

The novel Coronavirus Disease 2019 (Covid-19), which emerged at Wuhan, China, in December 2019, has spread worldwide in a quick time and declared a pandemic by World Health Organization (WHO) on March 11, 2020. Though the outbreak of this pandemic has been diminished in China as a local shock [1], the number of Covid-19 affected people and the death toll keeps increasing worldwide as a global shock. As of August 2020, around 25.27 million infected cases were confirmed, and 0.87 million deaths were reported around the world (Figure 1(a)) [2].

In Bangladesh, the first Covid-19 report was confirmed for March 8, 2020. Since then, the number of affected people has been increasing rapidly. Bangladesh has reported 0.3 million infection cases and 4,281 deaths until August 2020 (Figure 1 (b)) [2]. Although it may be evident that the severity of Covid-19 has slowed down recently as the global lockdown is withdrawn globally, Strzelecki has found evidence of a worldwide second wave of coronavirus from the outbreaks in South Korea, Italy, and Iran [3].

The covid-19 pandemic has constrained economic mobility, caused the shutting down of the factories, and stopped the education and training of people around the world [4]. Besides, restrictions on international travel

and tourism, and many other sectors are also severely affected by the outbreak [5].

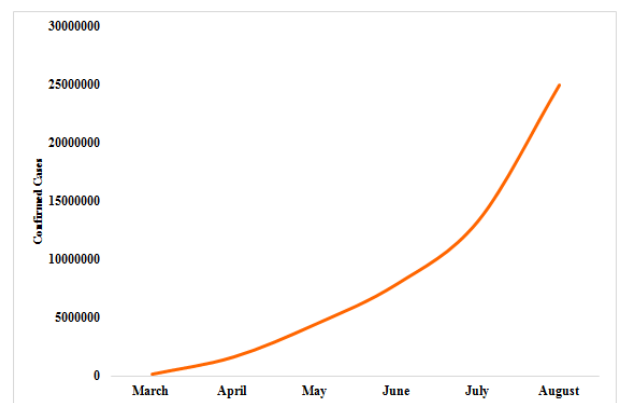

**Fig. 1(a).** Worldwide total confirmed Covid-19 cases (until August 2020). (Source: Worldometers Report, 2020)

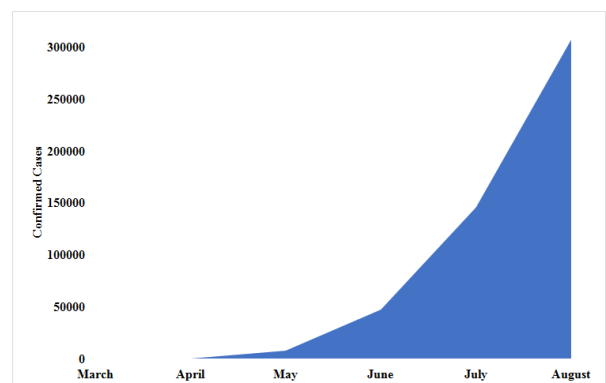

**Fig. 1(b):** Bangladesh's total confirmed Covid-19 cases (until August 2020). (Source: Worldometers Report, 2020)

\*School of Business and Economics, North South University, Bashundhara, Dhaka 1229, Bangladesh.

<sup>+</sup> Bangladesh University of Professionals (BUP), Mirpur Cantonment, Dhaka-1216, Bangladesh.

<sup>1</sup>Corresponding author;

Tel: +8801758871668, Fax: + 880255668202

E-mail: [sakib.amin@northsouth.edu](mailto:sakib.amin@northsouth.edu)

The pandemic also significantly affects the energy sector, with a nosedive in total energy demand, driven by a fall in business and industrial activities [6]. Due to this lockdown, transportation usage has been dropped substantially, resulting in a reduction in global fossil fuel consumption, leading to a fall in environmental pollution [7]. The aviation industry worldwide is also affected adversely, causing a massive decline in global oil demand.

Although it is argued that the Covid-19 may hurt the energy sector, very few studies have been conducted on the impacts of the Covid-19 outbreak on the energy sector. Eroglu has conducted a literature review on the effects of the Covid-19 outbreak on the renewable energy sector and the environment from a global perspective [8]. He also has discussed the importance and scopes for future research of this topic in achieving future global energy security.

Akrofi and Antwi have reviewed the challenges posed to Africa's governments' energy industry [9]. They have found that most of the government initiatives are short-term focused (fiscal or financial measures). They have also revealed no specific mention of standards for the energy sector, especially for the renewable energy sector from medium to long-term. The study has recommended that the government should tackle the pandemic's aftershock challenges in the energy sector and drive the clean energy transition and bolster their economies.

In his study, Hosseini has further highlighted that the pandemic caused a short-run shrinkage towards globally developing sustainable renewable energy. The governments should offer incentive packages to stimulate the private sectors and society to invest in renewables [10]. Gillingham *et al.* revealed that the lockdown and the reduced volume of economic activities had improved air quality in the USA [11]. However, they argued this improvement as a temporary phenomenon as the investment in the clean energy projects is expected to decline as a move towards diverting the resources in the other prioritising sectors like health, education, etc.

Mastropietro *et al.* have emphasised the direct impact of the Covid-19 pandemic on the energy sector [12]. They have discussed that this global lockdown situation could deteriorate the energy insecurity around the world. The study has also identified some of the governments worldwide' emergency initiatives and recommended to provide assistance based on appropriate targeting and steady financing to reduce inefficiency.

The Covid-19 global pandemic has recently evolved into an economic and a humanitarian crisis of mammoth proportions. As governments have put restrictions on the movement of the populations to contain the epidemic to save lives, regular economic activities have been disrupted, leaving millions of people jobless, and pushing them into poverty and hunger. The pandemic has already slowed down Bangladesh's economic

activities, and the most widespread impact of this slowdown has been a loss of income for most 52 million informal workers [13], [14].

The aftermath of the pandemic urges the revision of the existing energy policy in Bangladesh for twofold reasons: poor performance in improving the off-grid electrification by expediting renewable energy and the issue of recent generation overcapacity. So far, only 633.31 Megawatt (MW) of electricity (2.85 percent of the total generation capacity) is produced from renewables, which is far less than the actual target of generating 10 percent of renewable electricity energies.

The concern of generation overcapacity, underutilisation of the power plants, and the fiscal burden has been exacerbated during the Covid-19 period and further expected to deteriorate in the post-pandemic era in Bangladesh [15]. For instance, the overcapacity rate of 49.8 percent in 2020 is found well above the targeted reserve capacity of 25 percent, as mentioned in the Power Sector Master Plan (PSMP) 2016 [16].

Given this background, we argue that there is a necessity to study the post-pandemic consequences on the Bangladesh energy sector to revise the existing power sector master plan and help the country achieve the Sustainable Development Goals (SDGs) and ensure energy security, and become a high-income nation by 2041. Bangladesh Power Development Board (BPDB) also suggests that this is the optimal time to change the power generation policies for long term energy security and economic sustainability.

To our knowledge, there is no previous study to analyse the adverse consequences of the Covid-19 in Bangladesh energy sector and the other similar countries. This paper's main objective is to examine the short-run and long-run effects of the Covid-19 pandemic on the Bangladesh energy sector and economy for future policy revision in the energy policies in terms of the generation mixes.

We use a Seasonal Autoregressive Moving Average (SARIMA) model to generate a counterfactual demand in the nationwide general holiday period using the SARIMA (1, 0, 0) (0, 1, 0) [12] model. Also, we forecast the electricity demand for Bangladesh for the next two years, using electricity data until June 2020, and find SARIMA (1,0,0) (1,1,0) as the best-suited model for this period of data. Moreover, to capture the long-run effects of the Covid-19 aftermath in the energy sector, we employ a Dynamic General Equilibrium (DGE) model developed by Amin and Marsiliani [17] Bangladesh energy sector. The assumptions made and the functional forms of the model follow those of Kim and Loungani(1991) and Dhawan and Jeske (2008) [18], [19].

The benchmark model is calibrated and simulated for the Bangladesh economy, with a no lockdown scenario (government does not impose a general holiday). In the policy experiment, we simulate an economy where the government imposes general holiday, reducing the labour availability by 50 percent



and finding results in terms of the steady-state values of the GDP, standard consumption, and electricity consumption.

The paper is organised as follows. Recent power generation options in Bangladesh are presented in Section 2, followed by a discussion on the economic impact of Covid-19 in Bangladesh in Section 3. Section 4 briefly discusses the SARIMA and DGE models and discusses the effects of Covid-19 in the Bangladesh energy sector. Finally, conclusions and policy implications are presented in Section 5.

## 2. RECENT POWER GENERATION OPTIONS IN BANGLADESH

When the present government came into power in 2009, they faced two major problems in the energy sector. Firstly, the economy was not reaching its full potential due to an inadequate supply of electricity. During 2000–2009, electricity demand always exceeded supply by 2,000 MW on average. Secondly, the country faced too much reliance on natural gas as more than 90 percent of the electricity was produced using natural gas up to 2009. However, the reserve of natural gas in Bangladesh is limited and expected to last until 2031 [20], [21]. Moreover, Bangladesh's energy security and economic stability were threatened by the scarcity of fossil fuel resources, poor operational maintenance, financial performance, lack of trained human resources, and a low number of electricity generation plants. Realising the energy sector's decisive role in the country's development process, the present government started a wide range of reform policies since 2009 [22].

Bangladesh's government started undertaking the reform initiatives to ensure necessary energy supplies for its users to support steady socio-economic development. The central reform policies include i) introduction of rental and quick rental power generation as the emergency measures to cope with the power shortage; ii) maximisation of green energy and promotion of its introduction; iii) a legal framework for energy efficiency; iv) fuel diversification in the electricity generation mix; v) revising the energy prices to ensure cost-reflective pricing; vi) encouraging the private companies to enter the energy market; vii) enhancement of imported energy infrastructure and its flexible operation; viii) following a generation plan up to 2023; and ix) export credit agency for financing energy projects.

Moreover, the Bangladesh government formulated extensive energy and power development plan, the Power System Master Plan (PSMP), in 2016, for achieving sustainable development goals in harmonising with economic optimisation.

These initiatives have played a crucial role in strengthening the Bangladesh energy sector over the past 10 years. For instance, there are currently 126 power plants as compared to 27 back in 2009. The net installed electricity generation capacity has increased from 5,272

MW in 2009 to 23,518 MW in 2020, as found in the annual reports of BPDB (Figure 2). Accessibility of electricity has also been increased from 47 percent in 2009 to a whopping 96 percent in 2020. These achievements are aligned with the government's commitment to ensuring access to affordable and reliable electricity by 2021.

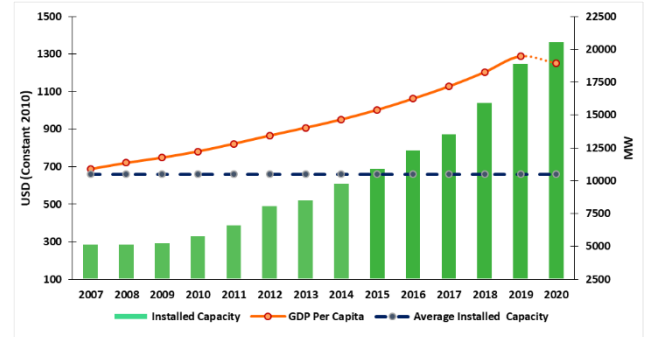

**Fig. 2. Overview of installed capacity and GDP per capita in Bangladesh.** (Source: Bangladesh Power Development Board (BPDB, 2020) and World Development Indicators (WDI, 2020))

Following the oil price shocks in the 1970s, natural gas became the energy of choice in Bangladesh until 2008. Available evidence suggests that the proven recoverable reserve of natural gas in Bangladesh is expected to last till 2031 if the current extraction rate does not change. Given this background, the Bangladesh government attaches high priority to Liquefied Natural Gas (LNG) based power generation as LNG imports can fill the demand and supply gap. Bangladesh now has two Floating Storage and Regasification Units (FSRUs) with a total capacity of 7.5 Million Tonnes per Annum (MTPA) of LNG. The country is also building a land-based terminal that can further handle 7.5 MTPA of LNG, expected to be ready in five years. By 2041, the share of natural gas/LNG will be 35 percent in the electricity generation mix.

There have been suggestions for using coal, as it has been one of the vital resources for electricity generation worldwide. At present, the global average of coal usage in the fuel mix is 41 percent, whereas Bangladesh uses only 2.36 percent. The government aims to steadily increase coal share by up to 35 percent by 2041 and reduce the pressure from liquid fuels. Also, initiatives have been taken for implementing a good number of mega projects such as Matarbari Ultra Super Critical Coal-Fired Power Plant, Payra Thermal Power Plant, and Maitri Super Thermal Power Plant in Rampal to ensure energy security in the future.

Since nuclear power is also one of the cheapest options for generating electricity worldwide, nuclear power generation is also included in the Bangladesh government's agendas to meet the rapidly increasing demand for electricity. It is assumed that the first 1,200 MW nuclear power plant is to start its operations by 2024. Bangladesh's government is also aware of the

development of legal systems and human resources relating to international cooperation and nuclear power, thus, prudently addressing the issues. It is expected that the share of nuclear power will be around 10 percent in 2041.

The use of liquid-fuel in the energy sector started increasing rapidly from the introduction of rental/quick rental (QR) companies. The use of imported High-Speed Diesel (HSD) and Furnace Oil (FO) had increased from around 5 percent in 2009 to 32 percent in 2019. The total cost of imported petroleum products has also increased almost 2 times in the previous 10 years.

Using QR power plants is a well-established choice across the world to resolve the power crisis urgently. There did not seem to exist any better solutions to the problem at that time in Bangladesh. However, the Bangladesh government is now thinking about gradually phasing out the QR power plants and looking into alternative fuels for electricity generation. According to the generation mix of 2041, the share of liquid fuel will be only 5 percent.

Bangladesh's government targets 15 percent of the projected demand of 2041 by importing electricity from neighbouring countries. Thus, regional cooperation will help ensure energy security in the future. At present, Bangladesh mainly imports 1,160 MW of electricity from India besides its generation.

The prospect of renewable energy in Bangladesh is bright, particularly for solar (Table 1) due to the high solar radiation (4.0 to 6.5 kWh/m<sup>2</sup>/day). Bangladesh is recognised as one of the first countries in the world to implement Solar Home Systems (SHSs) in reaching consumers outside the national grid (Off-grid) or in places where the grid connection is delayed. Almost 18 million people are getting access to electricity from SHSs in Bangladesh.

However, due to the existing market barriers, renewable energy will supplement conventional energy production in the immediate future [23]. In 2018 and 2019, renewable energy shares were 2.66 percent and 2.85 percent in the electricity generation mix, respectively, far behind the world standard and the target set by National Renewable Energy Policy (NREP) 2008. The government has also completed wind mapping in 9 spots and plans to generate 1,100 MW of electricity from wind power by 2021.

**Table 1: Renewable energy by type in 2019.**

Renewable Sources	On-grid (MW)	Off-grid (MW)	Total (MW)
Solar	81.22	318.16	399.38
Wind	0.90	2.00	2.90
Hydro	230.00	0.00	230
Biogas	0.00	0.63	0.63
Biomass	0.00	0.40	0.40
Total	312.12	321.19	633.31

Source: Sustainable and Renewable Energy Development Authority (SREDA, 2019).

### 3. ECONOMIC IMPACT OF COVID-19 IN BANGLADESH

The Covid-19 pandemic has made a massive shutdown in all types of business activities. The rapid spread of the virus has also caused a substantial reduction in all forms of economic activities worldwide. According to the Asian Development Bank (ADB) projection, this havoc could lead to a global recession like 2008 due to the economic and financial difficulties [24]. The International Monetary Fund (IMF), United Nations Conference on Trade and Development (UNCTAD), and the Organization for Economic Co-operation and Development (OECD) are all projecting significant economic losses in 2020, the decline of being about 1.6 percent, 1.7 percent, and 2.4 percent of global GDP, respectively [23], [25], [26].

Bangladesh is also no exception to this trend. The World Bank has forecasted that Bangladesh's economic growth in 2020 will be between 2.0-3.0 percent, while the IMF projected this to be 3.8 percent [27], [28]. ADB has already projected that this Covid-19 outbreak will reduce about 0.2 to 0.4 percent of Bangladesh GDP [29].

The economy of Bangladesh has already faced the repercussion of this crisis. The nationwide general holiday has halted the economic activities related to national and international trade, transport, remittance and supply chain of foods, informal job sectors, etc. The crisis's shock has already invaded different economic areas, including export outflow, import inflow, tourist arrival, out-migration, and investment flows [15].

Due to the adverse impact of worldwide trade, the global supply chain has also faced interruption. The trade deficit has increased to 17,861 million US Dollars in 2020 due to the decline in exports and imports by 16.9 percent 8.6 percent respectively [30]. About one-fifth of Bangladesh's global imports mainly come from mainland China. A two percent reduction of Chinese exports in intermediary inputs could cause USD 16 million trade loss to Bangladesh [23]. So, this pandemic would surely disrupt the supply chain in Bangladesh's context (Figure 3).

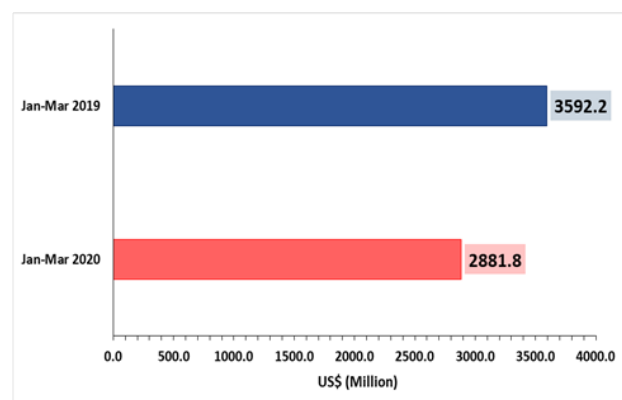

**Fig. 3: Import payment to China from Bangladesh in 2019 and 2020. (Source: Bangladesh Bank, 2020)**

On Bangladesh's export side, the major exporting countries are the worst Covid-19 affected countries globally, such as- the USA, Germany, UK, and Spain. [31] The Covid-19 shock in the western countries would reduce the demand for Bangladesh's Ready-Made Garments (RMG) products by 8 percent, resulting in an overall fall in total export earnings. Figure (4) illustrates that the RMG export (January 2020-March 2020) has reduced by 403 million USD from the equivalent period in 2019.

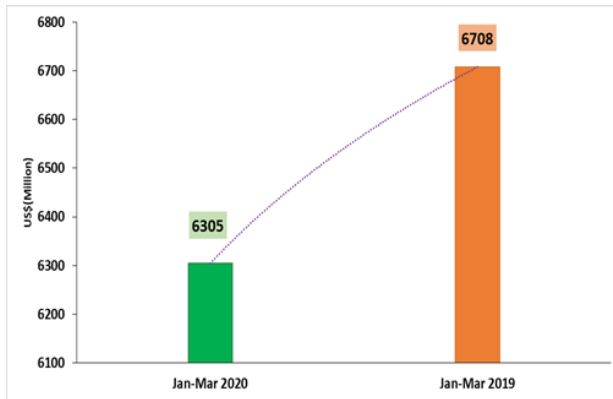

**Fig. 4. RMG export from Bangladesh in 2019 and 2020.**  
(Source: Bangladesh Bank, 2020)

The Covid-19 has already caused a downturn effect on the remittance inflow in Bangladesh. However, Figure 5 shows that remittance inflow has started to increase in recent months after the reduction from January 2020 to April 2020. Most emigrant workers from Bangladesh work in the Middle-East countries, and the global drop in oil prices has caused an adverse economic shock in those countries. However, this is too early to predict the scenario of the future trend amid this pandemic situation. According to the different reports of Bangladesh Bank, much overseas employment of the Bangladeshi workers and professionals has sharply declined in 2020. Many workers have already become jobless, so the recent upward trend may not be sustainable in the future [30].

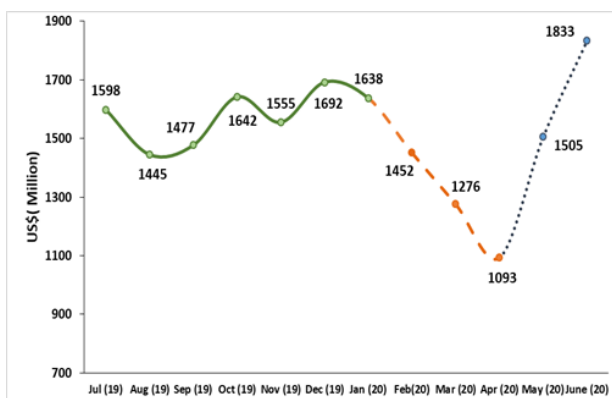

**Fig. 5. Remittance inflow in Bangladesh in 2019 and 2020.**  
(Source: Bangladesh Bank, 2020)

In the Covid-19 era, the tourism sector is one of the worst affected sectors around the world. Every sub-sector related to tourism, such as transport, hotels, sites, and travel agencies, are affected due to this crisis. The World Travel and Tourism Council (WTTC) has estimated that 2.7 trillion USD in revenue could be lost globally in 2020 due to the Covid-19 pandemic [32]. The United Nations World Tourism Organization (UNWTO) [33] has predicted that Bangladesh's tourism industry would face a revenue loss of around 470 million USD in 2020. More than 0.3 million people engaged in the tourism industry may lose their jobs due to the significant drop in Bangladesh's tourism activities and revenues [34].

In an online survey by the Bangladesh Institute of Development Studies (BIDS), it has been found that about 13 percent of people have become unemployed in the country due to the Covid-19 pandemic [35]. ADB [36], by conducting a simulation analysis, has recently shown that if Bangladesh faces larger contamination, then agriculture and mining, manufacturing, and transport sectors might see 4.32 percent, 3.92 percent, and 4.57 percent job losses, respectively.

From the Labour Force Survey 2016-17 of the Bangladesh Bureau of Statistics (BBS), it has been revealed that the youth unemployment rate of 10.6 percent is much higher than the national average of 4.2 percent [37]. The report has also shown a high degree of unemployment among educated youth, as 13.4 percent of unemployed youths have tertiary education, and another 22.3 percent have higher secondary education. Besides, about 82 percent of employment in Bangladesh is in the informal sector. So, the pandemic is expected to affect the informal sector dreadfully compared to Bangladesh's formal sector.

Moreover, around 87 percent of the Small and Medium Enterprises (SMEs) in Bangladesh operate informally and highly rely on a few important religious and cultural events. So, the Covid-19 related general holiday initiatives have generated tremendous financial loss to these SMEs [15]. The BIDS has shown that the SMEs, especially those from rural and semi-urban areas, have shown that the SMEs are the most sufferers during this pandemic. Comparing with the previous year's revenue data, it has also been highlighted that the average revenue reduction for all SMEs in 2020 is 66 percent [35]. The survey has also revealed that more than three-fourth of the goods produced by the entrepreneurs remain unsold.

The Covid-19 pandemic has also created inflationary pressure in Bangladesh. One of the possible reasons is the increase in out of pocket medical expenses (a type of non-food expenditure), which resulted from a sudden disruption in the domestic and international supply chains for necessary medical equipment (such as masks, test kits, medicines, disinfectant chemicals, etc.) According to the recent Bangladesh Bank report, CPI-based general inflation stood at 5.65 percent in the fiscal



year 2020 compared to the inflation rate of 5.47 percent in 2019 (Figure 6).

Besides, BIDS online survey has shown the expected and significant adverse effects on employment, income, and expenditures of people, especially those from low-income groups in this pandemic situation [35]. About one-fifth of the participants with income less than 5,000 takas have reported that their income was reduced by 75 percent. About one-fourth of the participants with income between 5,000-15,000 takas have reported a reduction by 50 percent relative to last month's pay. The survey has shown that Bangladesh will have 16.4 million new poor in 2020 as the working class income in urban and rural areas has fallen sharply due to the general holiday to stop the Covid-19 pandemic spread.

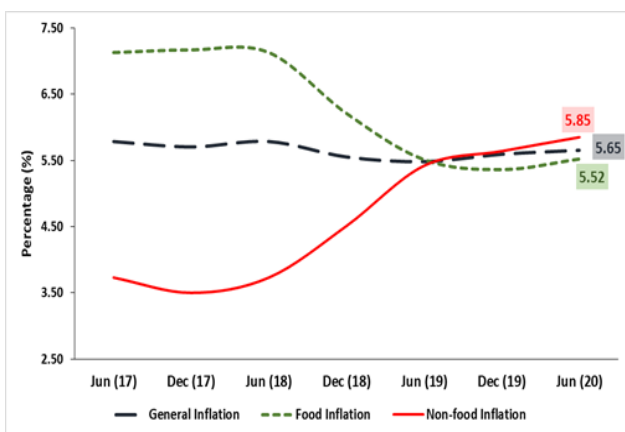

Fig. 6. 12-month average CPI of Bangladesh from 2015 to 2020 (Source: Bangladesh Bank, 2020).

In Bangladesh, the majority (more than 80 percent) of the governmental revenue comes from the National Board of Revenue (NBR) sources. According to the Ministry of Finance Statistics (2020), the Government of Bangladesh, both the NBR and non-NBR tax revenues, have experienced negative growth rates of 6 percent and 4.3 percent, respectively, during the second quarter of 2020 compared to the equal period in 2019 [30]. Low revenue mobilisation in the pandemic situation is expected to mount budgetary pressure for the country.

Covid-19 may also severely affect the financial sector of Bangladesh. Private sector credit growth has been declining for a longer time, and in June 2020, credit growth has dropped to 8.6 percent [30]. This pandemic situation will surely disrupt the banks' capacity to give out loans at a massive level.

#### 4. IMPACT OF COVID-19 IN BANGLADESH ENERGY SECTOR: AN EMPIRICAL AND SIMULATION EXERCISE

To observe the Covid-19 pandemic effect on Bangladesh's energy sector, the seasonal electricity demand from 2016 to 2020 is shown in Figure 7. The figure depicts the seasonality features and increasing trend in electricity demand since 2016. However, the

situation is different in the case of 2020. The electricity demand in March 2020 is found to be higher than in 2019. However, it has started declining sharply from April 2020, and till June 2020 (at the time of writing this paper), it is still lower than the 2019 level. This is due to the fact that Bangladesh declared a nationwide general holiday on March 24. However, electricity demand is catching up at a high rate because of the relaxation of general holiday measures in the subsequent period, and in June 2020, it is just below the 2019 level.

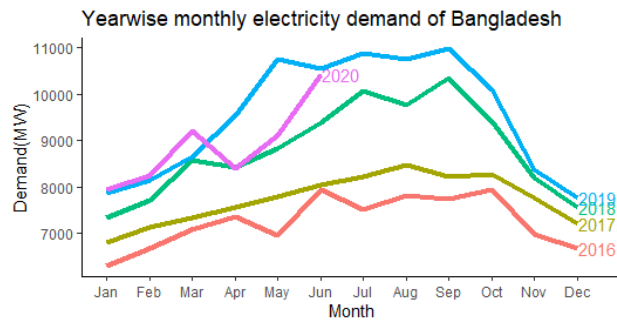

Fig. 7. Comparison of Bangladesh's seasonal electricity demand for 2016, 2017, 2018, 2019, and 2020 (Source: Bangladesh Power Development Board, BPDB, 2020).

In this paper, we have used SARIMA (1, 0, 0) (0, 1, 0) [12] model <sup>2</sup> to generate a counterfactual value of electricity demand for Bangladesh during the lockdown period, using pre-general holiday (January 2016 to March 2020) electricity data. The SARIMA (1, 0, 0) (0, 1, 0) [12] model is revealed as the best model in the auto.arima function of R. Instead of traditional Box-Jenkins methodology, auto.arima is a function of forecast package, which uses corrected Akaike Information Criteria (AIC) to select the order of ARIMA models and it uses an algorithm, created by Hyndman and Khandakar [38]. It runs a series of different ARIMA models and chooses the best fitted ARIMA model by corrected AIC.

This counterfactual value of electricity demand is created to see the effect of lockdown on electricity demand in Bangladesh. We can see from Table 2 that general holiday had a significant impact for April, May, and June. Even though the real electricity data was available from April to June, the simulation is done to determine the electricity demand if the situation was normal.

Table 2. Comparison of forecasted electricity demand and real electricity demand (1, 0, 0) (0, 1, 0).

Month	Counterfactual Values	Real Values	Estimated Demand Gap
April	10175.3	8400.9	1774.5
May	11406.3	9097.6	2308.7
June	11229.4	10425.6	803.7

Source: Bangladesh Power Development Board, BPDB, 2020

<sup>2</sup> For more details, see [54]

We have collected the daily data in MW from the Bangladesh Power Development Board. <sup>3</sup> The data are then averaged, summing each month's specific daily data and then dividing it by the number of days of that particular month and converted into mean daily data per month. Therefore, we have avoided the weekly seasonality that stems from the daily electricity data.

SARIMA model was previously used in Bangladesh to forecast the Dengue epidemic's consequences in Bangladesh [39]. Moreover, the SARIMA model's application is also evident in assessing the different pandemic aspects worldwide [40]–[44]. Usage of the SARIMA model to forecast short-run electricity demand is very prevalent in literature [45]–[47].

We have then used data from January 2016 to June 2020 to accommodate the effect of general holiday in our SARIMA model and forecast the electricity demand for the next 24 months. In this case, the SARIMA (1, 0, 0) (1, 1, 0) [12] model is found to be the best fit model in auto.arima function. The forecasted values are presented in Table 3. Figure 8 is drawn from the values of Table 3, where dark blue shades show an 80 percent confidence level, and light blue shades show a 95 percent confidence level. The validity of the model has been checked by the Ljung-Box test and found that the p-value is 0.14. It means residuals are white noise only, and this model perfectly fits this time series data. Figure A1 in Appendix shows the residuals of this model.

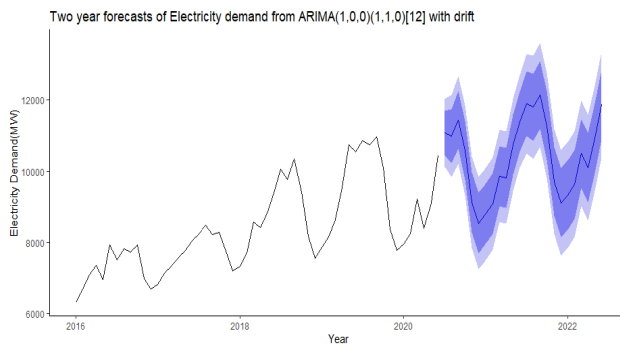

**Fig. 8. Two-year forecast for electricity demand of Bangladesh.** (Source: Authors' calculation)

Following Amin [47] and Amin and Marsiliani [17] <sup>4</sup>, we also present a Dynamic General Equilibrium (DGE) model for Bangladesh economy to capture the long-run consequences of the Covid-19 towards Bangladesh energy sector and economy [48]. DGE models have become popular days among researchers to analyse the sectoral changes within an economy caused by sudden shocks like the Covid-19 [49]. These models can provide meaningful insights into the policymakers through the simulation exercises in a general equilibrium framework.

References [48], [50] argue that the DGE models are more appropriate than the other macro models and input-output models to find the long-run steady-state scenarios from any exogenous shocks. However, it is worth noting that they are not proven to be useful to capture the short-run changes in the economy. Accordingly, we have employed the SARIMA model in this paper to capture the short-run scenarios for policy reasons.

The use of general equilibrium models to examine adverse economic effects from the health outbreaks is not an old phenomenon [51]. Recently, using a hybrid of a CGE model and a Dynamic Stochastic General Equilibrium (DSGE) model, [52] have revealed that depending on the epidemiological scenario considered, the GDP loss can range from 283 to 9,170 billion USD worldwide. Moreover, [53] have found that Covid-19 caused global GDP to fall by 2 percent due to a decline in trade services, increased trade costs, and sub-optimal labour and capital use.

Following [17], the firm's production function is described by a Cobb-Douglas production function.

$$Y_t = A k_t^\alpha (V \cdot l_t^\gamma) g_t^{1-\alpha-\gamma} \quad (1)$$

Where  $\alpha$  and  $\gamma$  is the share of capital input ( $k_t$ ) and labour input ( $l_t$ ) in aggregate output, respectively, and  $1-\alpha-\gamma$  is the share that goes to the energy input ( $g_t$ ).  $V$  is the lockdown parameter where it takes the value of 1 in the benchmark model with no general holiday scenario.

Households consume electricity ( $e_t$ ), standard consumption goods ( $c_t$ ), and leisure ( $1-l_t$ ) and receive utility as follows.

$$u_t = \varphi \ln [\theta c_t^\rho + (1-\theta)e_t^\rho]^{\frac{1}{\rho}} + (1-\varphi) \ln (1-l_t) \quad (2)$$

Here,  $\varphi$  represents the share of consumption in the household's utility, where  $\varphi \in (0, 1)$ .  $\theta$  is the share of standard consumption in the household's aggregator, where  $\theta \in (0, 1)$ . The utility function shows the commonly assumed properties like  $u_c > 0$ ,  $u_{cc} < 0$ ,  $\lim_{c \rightarrow 0} = \infty$  and  $\lim_{c \rightarrow \infty} = 0$ .

The price of energy used in the economy,  $P_t$ , is exogenously given. As energy is used both by the consumers and the producers in this model, the economy's resource constraint for period  $t$  is given by:

$$Y_t = c_t + i_t + P_t (e_t + g_t) \quad (3)$$

The Lagrangian to the planning problem can be written as follows.

$$\begin{aligned} L &= \sum_{t=0}^{\infty} \beta^t \left( \varphi \log [\theta c_t^\rho + (1-\theta)e_t^\rho]^{\frac{1}{\rho}} \right. \\ &+ (1-\varphi) \log(1-l_t) \left. \right) + \lambda_t [A k_t^\alpha (V \cdot l_t^\gamma) g_t^{1-\alpha-\gamma} \\ &+ (1-\delta)k_t - c_t - P_t (e_t + g_t)] \end{aligned} \quad (4)$$

<sup>3</sup> <https://www.bpdb.gov.bd/>

<sup>4</sup> For more details, see [48].

Where  $\beta$  is the discount factor,  $\lambda_t$  is the Lagrange multiplier, and the function is maximised for  $c_t$ ,  $k_{t+1}$ ,  $e_t$ ,  $l_t$ ,  $g_t$ , and  $\lambda_t$ .

We calibrate and simulate the model for the Bangladesh economy for quarterly frequency and then compare the steady-state values of the benchmark model's key variables with a policy experiment of 50 per cent reduced labour due to isolation associated with the general holiday. It is worth noting that general holiday caused a persistent labour shortage, and the supply shock would reduce the output. During the general holiday, the households also stayed at home, which adversely affected the income level and lower the demand (demand-side effect). Both the demand and supply-side shocks argue that the economy goes through

a large contraction with reduced electricity and energy demand due to the lockdown.

We run the program Dynare version 4.6.1 to solve and simulate the model. The structural parameter values are listed in Table A1 in the Appendix. Our results reveal that due to the Covid-19, Bangladesh's GDP growth rate would be around 4.5 percent in the long-run. These results are consistent with the IMF and WB predictions, as discussed in Section 3. We further simulate that the steady-state electricity demand and standard consumption values would fall by 8-10 percent and 6 percent, respectively. We check the robustness of these results with varying lockdown parameters ( $V=0.20$  and  $V=0.33$ ) and find almost similar results.

**Table 3. Forecasted electricity demand from SARIMA (1, 0, 0) (1, 1, 0) [12] model.**

Month	Point Forecast	Lo.80	Hi.80	Lo.95	Hi.95
Jul-20	11072.8	10452.1	11693.5	10123.6	12022.1
Aug-20	10990.6	10240.2	11740.9	9843.0	12138.1
Sep-20	11440.4	10637.3	12243.6	10212.1	12668.8
Oct-20	10592.2	9765.8	11418.6	9328.4	11856.1
Nov-20	9135.1	8298.2	9972.0	7855.2	10415.1
Dec-20	8542.2	7700.5	9383.9	7254.9	9829.4
Jan-21	8788.9	7945.0	9632.9	7498.3	10079.6
Feb-21	9094.4	8249.5	9939.4	7802.2	10386.7
Mar-21	9863.4	9018.0	10708.8	8570.4	11156.3
Apr-21	9818.9	8973.3	10664.6	8525.7	11112.2
May-21	10742.9	9897.2	11588.6	9449.5	12036.3
Jun-21	11391.1	10545.3	12236.9	10097.6	12684.6
Jul-21	11893.4	10978.5	12808.3	10494.2	13292.6
Aug-21	11797.6	10852.6	12742.7	10352.3	13243.0
Sep-21	12144.0	11185.3	13102.7	10677.8	13610.2
Oct-21	11284.6	10319.7	12249.5	9808.9	12760.3
Nov-21	9713.9	8746.2	10681.7	8233.9	11194.0
Dec-21	9116.0	8146.9	10085.1	7633.9	10598.1
Jan-22	9328.6	8358.9	10298.2	7845.6	10811.6
Feb-22	9630.1	8660.1	10600.0	8146.6	11113.5
Mar-22	10490.9	9520.8	11461.0	9007.3	11974.6
Apr-22	10101.1	9130.9	11071.2	8617.3	11584.8
May-22	10923.4	9953.2	11893.5	9439.6	12407.1
Jun-22	11875.9	10905.7	12846.1	10392.1	13359.6

(Source: Authors' own calculation)

## 5. CONCLUSION AND POLICY RECOMMENDATIONS

Given our results of lower GDP and reduced electricity demand, we argue that Bangladesh may reconsider its energy generation policy towards more efficient and sustainable energy production and distribution. The Bangladesh government previously adopted coal-based mega power plants to meet the historical energy crisis

associated with the shortage of electricity supply. Considering the growing public concerns, the government can reduce the dependency on coal use in the fuel mix capacity for future electricity generation.

This reduced demand for electricity and the over-generation capacity may also coexist for a couple of years more. Therefore, policymakers may take a planning model in which decisions are taken both proactively and reactively, and the organisational

environment should be predictable and stable [47]. Due to the adverse impact on the environment for utilising finite energy resources, many developed and developing countries are now inclined toward various forms of renewable energy like solar power, wind power, bioenergy, hydropower, etc. [15].

We argue that a pragmatic intra- and inter-sectoral shift in resource allocation in the energy sector and a review of the power sector master plan is needed for the Bangladesh energy sector. The energy sector's ADP allocation shows that the renewable energy sector was somewhat overlooked while formulating energy policies [13]. The ADP share of renewable energy lies around 4-9 percent for a long time. So, the government can consider re-evaluating the effectiveness of the mega projects of electricity from fossil fuels in the ADP and diversify a part of the resources allocated for these mega projects towards the renewable energy sector. Given our results, we also highlight that government may start phasing out QRs by not renewing the contracts further and bringing changes in the existing agreements.

We also recommend the policymakers to link up our energy system and exploit the synergies enabled by an Integrated Energy System (IES). The IES can ensure a hybrid solution to the existing energy options for generating future electricity sources to reduce fossil-fuel dependency in Bangladesh. A diverse range of energy efficiency programmes could be implemented for the country's future energy security. The government could also take the necessary steps to develop efficient transmission and distribution mechanisms for uninterrupted electricity supply.

Our model can be generalised by introducing different types of households, firms, a detailed disaggregated energy sector, and a government sector to review Covid-19 energy policies in Bangladesh carefully.

#### ACKNOWLEDGEMENT

We would like to thank the anonymous referees for their helpful comments, which significantly improved the paper. The corresponding author is also thankful to Dr. Laura Marsiliani and Dr. Thomas Renström from Durham University Business School, United Kingdom.

#### REFERENCES

- [1] Gautam S. and L. Hens. 2020. SARS-CoV-2 pandemic in India: What might we expect? *Environment, Development and Sustainability* 22 (5): 3867–3869.
- [2] Worldometers, 2020. Worldometers Report [Online] Retrieved from the World Wide Web: <https://www.worldometers.info/coronavirus/>.
- [3] Strzelecki A., 2020. The second worldwide wave of interest in coronavirus since the COVID-19 outbreaks in South Korea, Italy and Iran: A Google Trends study. *Brain, Behavior, and Immunity*. Academic Press Inc.
- [4] Bandyopadhyay S., 2020. Coronavirus Disease 2019 (COVID-19): We shall overcome. *Clean Technologies and Environmental Policy* 22 (3): 545–546.
- [5] Doherty B., 2020. Qantas slashes flights as coronavirus hits passenger numbers | Qantas | The Guardian. *The Guardian*.
- [6] IEA, 2020. Global Energy Review 2020 – Analysis. *IEA*.
- [7] Chen K., Wang M., Huang C., Kinney P.L., and Anastas P. T., 2020. Air pollution reduction and mortality benefit during the COVID-19 outbreak in China. *Lancet Planetary Health* 4 (6): e210–e212.
- [8] Eroğlu H., 2020. Effects of Covid-19 outbreak on environment and renewable energy sector,” *Environment, Development and Sustainability* :1–9.
- [9] Akrofi M.M.C. and S.H. Antwi. 2020. COVID-19 energy sector responses in Africa: A review of preliminary government interventions. *Energy Research and Social Science* 68: 101681.
- [10] Hosseini S.E., 2020. An outlook on the global development of renewable and sustainable energy at the time of COVID-19. *Energy Research and Social Science* 68: 101633.
- [11] Gillingham K.T., Knittel C.R., Li J., Ovaere M., and Reguant M., 2020. The Short-run and Long-run Effects of Covid-19 on Energy and the Environment.
- [12] Mastropietro P., Rodilla P., and Batlle C., 2020. Emergency measures to protect energy consumers during the Covid-19 pandemic: A global review and critical analysis,” *Energy Research and Social Science* 68: 101678.
- [13] Bin Amin S., 2020. Reviewing existing energy policy. *The Financial Express*.
- [14] Mujeri M.K., 2020. Saving informal sector workers from pandemic shock. *The Financial Express*.
- [15] CPD, 2020. Power sector: Burden of overcapacity demands redirection towards clean energy | CPD.
- [16] Power Division, 2016. Power system master plan 2016. *Ministry of Power, Energy and Mineral Resources of the Government of the People's Republic of Bangladesh* : 1–137.
- [17] Bin Amin S. and L. Marsiliani. 2015. Energy price shocks in dynamic stochastic general equilibrium: The case of Bangladesh. *Rev. Bus. Econ. Stud.* 30 (3): 12–21.
- [18] Kim I.-M.O. and P. Loungani. 1991. The Role of energy in real business cycle models.
- [19] Dhawan R. and K. Jeske, Energy price shocks and the macroeconomy: The role of consumer durables on JSTOR. *J. Money, Credit Bank.* 40 (7): 1357–1377
- [20] Amin S. and S. Rahman. 2018. *Energy resources in Bangladesh: Trends and contemporary issues*.
- [21] Bin Amin S. and F. Khan. 2020. Modelling energy demand in Bangladesh: An empirical analysis. *J.*



- Dev. Areas* 54(1).
- [22] Amin S., Jamasb T., Llorca M., Marsiliani L., and Renström T.I., 2019. Combining private and public resources: Captive power plants and electricity sector development in Bangladesh. *Emerg. Mark. Financ. Trade*.
- [23] UNCTAD, 2020. Global trade impact of the Coronavirus (COVID-19) epidemic.
- [24] Abiad A., Arao R., and Dagli S., 2020. The economic impact of the COVID-19 outbreak on developing Asia.
- [25] World Economic Outlook, 2020. Tentative stabilization, sluggish recovery? IMF, Washington DC.
- [26] Assessment, O.I.E., 2020. Coronavirus: The world economy at risk. OECD, Paris.
- [27] World Bank, 2020. The Cursed Blessing of Public Banks Washington DC.
- [28] IMF, 2020. Bangladesh: Requests for disbursement under the rapid credit facility and purchase under the rapid financing instrument—press release; Staff report; and statement by the executive director for Bangladesh. Washington DC.
- [29] Asian Development Bank, 2020. An updated assessment of the economic impact of COVID-19.
- [30] Bangladesh Bank, 2020. Monetary policy statement.
- [31] Razzaque A., 2020. Exports: Riding the waves of uncertainty. Dhaka.
- [32] WTTC, 2020. WTTC-2020 Press Release.
- [33] United Nations World Tourism Organization (UNWTO), 2020. Covid-19: Measures to support travel and tourism.
- [34] PATA Bangladesh Chapter, 2020. COVID-19 impact on the tourism industry in Bangladesh.
- [35] BIDS, 2020. Critical conversations 2020: In the shadow of COVID - Coping, Adjustments, Responses.
- [36] Asian Development Bank, 2020. COVID-19 Economic Impact Assessment Template [Online]. Retrieved September 27, 2020 from the World Wide Web: <https://data.adb.org/dataset/covid-19-economic-impact-assessment-template>.
- [37] BBS, 2018. Labour force survey (2016-17). Dhaka.
- [38] Hyndman R. and Y. Khandakar. 2007. Automatic time series for forecasting: the forecast package for R.
- [39] Choudhury M.A.H.Z., Banu S., and Islam M.A., 2008. Forecasting dengue incidence in Dhaka, Bangladesh: A time series analysis.
- [40] Roy S., Bhunia G.S., and Shit P.K., 2020. Spatial prediction of COVID-19 epidemic using ARIMA techniques in India. *Model. Earth Syst. Environ.* 1: 3.
- [41] Yang Q., Wang J., Ma H., and Wang X., 2020. Research on COVID-19 based on ARIMA model—Taking Hubei, China as an example to see the epidemic in Italy. *J. Infect. Public Health*.
- [42] Benvenuto D., Giovanetti M., Vassallo L., Angeletti S., and Ciccozzi M., “Application of the ARIMA model on the COVID-2019 epidemic dataset. *Data Br.* 29: 105340.
- [43] H. B and P.N.S. Prakash. 2020. Prediction of COVID-19 infected cases Using ARIMA: A case study.
- [44] Bayyurt L. and B. Bayyurt. 2020. Forecasting of COVID-19 Cases and Deaths Using ARIMA Models. *medRxiv*, p. 1–18.
- [45] Erdogdu E., 2007. Munich personal RePEc archive electricity demand analysis Using cointegration and ARIMA modelling: A case study of Turkey. *Energy Mark. Regul. Auth.* (19099).
- [46] Bowden N. and J.E. Payne. 2008. Short term forecasting of electricity prices for MISO hubs: Evidence from ARIMA-EGARCH models. *Energy Econ.* 30 (6): 3186–3197.
- [47] Wang Y., Wang J., Zhao G., and Dong Y., 2012. Application of residual modification approach in seasonal ARIMA for electricity demand forecasting: A case study of China. *Energy Policy* 48: 284–294.
- [48] Bin Amin S., 2015. The macroeconomics of energy price shocks and electricity market reforms: Case of Bangladesh. Durham University.
- [49] Burfisher M., 2017. Introduction to computable general equilibrium models. Cambridge University Press.
- [50] B. Lahcen *et al.*, 2020. Green Recovery Policies for the COVID-19 Crisis: Modelling the impact on the economy and greenhouse gas emissions *Environ. Resour. Econ.* 76.
- [51] Keogh-Brown M.R., Smith R.D., Edmunds J.W., and Beutels P., 2010. The macroeconomic impact of pandemic influenza: Estimates from models of the United Kingdom, France, Belgium and The Netherlands. *The European Journal of Health Economics* 11: 543–554.
- [52] McKibbin W.J. and R. Fernando. 2020. The Global macroeconomic impacts of COVID-19: Seven Scenarios. *SSRN Electron. J.*
- [53] Maliszewska M., Mattoo A. and Mensbrugge D., 2020. The potential impact of COVID-19 on GDP and trade. *SSRN Electronic Journal*. The World Bank.
- [54] Hyndman R.J. and G. Athanasopoulos. 2018. *Forecasting: Principles and practice*.

## APPENDIX A

Table A1. The parameter values.

$\beta$ , discount factor	0.96
$\alpha$ , capital share of output in the production function	0.31
$\gamma$ , labour share of output in the production function	0.65
$\delta$ , depreciation rate	0.025
$\varphi$ , the share of consumption in the household's utility	0.41
$\theta$ , the share of standard consumption	0.8
$\sigma$ , the CES parameter of household's utility function	-0.11
V, lockdown parameter	1 (no lockdown) 0.5 (lockdown)

Source: Bangladesh Household Income and Expenditure Survey (2010), Bangladesh Bureau of Statistics (BBS, 2015).

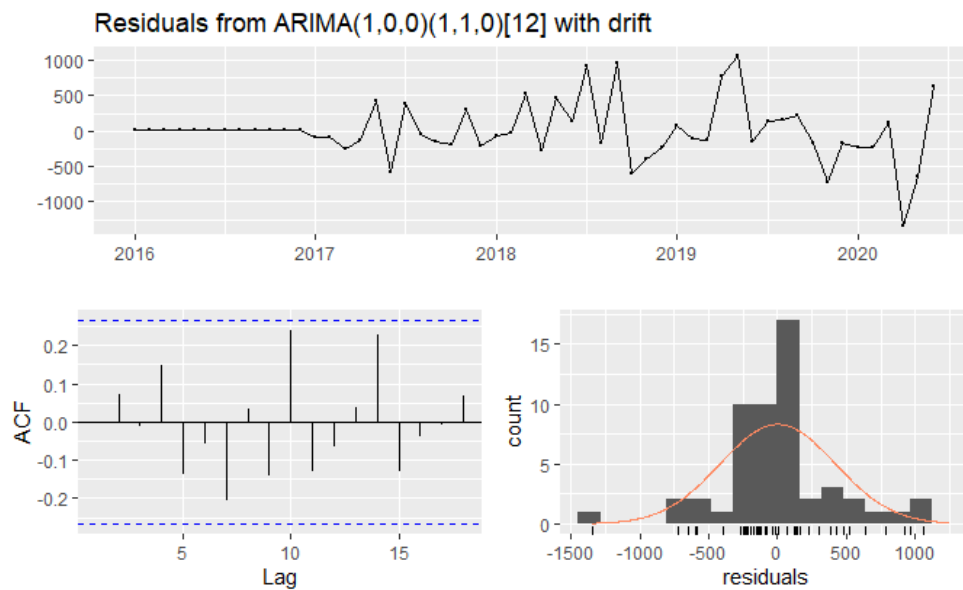

Fig. A1. Residuals from ARIMA (1,0,0) (1,1,0) [12] (Source: Authors' own calculation)





[www.ericjournal.ait.ac.th](http://www.ericjournal.ait.ac.th)

## Utilization of Soft Energy: Approach to Eco-Development in Rural Bangladesh

Md. Hafiz Iqbal\*<sup>1</sup> and Md Masumur Rahaman<sup>+</sup>

**Abstract** –This study has given efforts to detect socio-economic-demographic characteristics to provide the utilization of soft energy and estimates truncated mean willingness-to-pay (WTP) for the economic valuation of soft energy. A contingent valuation survey was carried out according to the NOAA guidelines to fulfill the research objectives. The survey involved 307 villagers from twenty villages of Pabna district. The zero-inflated ordered logistic model was employed to detect the significant determinants of WTP for soft energy utilization. The model results showed that age, family composition, years of schooling, monthly income, social mobilization, and payment are the important contributors in determining WTP for the utilization of soft energy. The lower value of the truncated mean of monthly WTP (Tk. 2177.60 or US\$: 25.69) compared to general mean WTP does not necessarily imply low demand for soft energy, as the findings from E(WTP) illustrate potential demand for soft energy in rural Bangladesh.

**Keywords** – contingent valuation, eco-development, energy economics, low carbon society, soft energy

### 1. INTRODUCTION

It is predicted that from 2011 to 2030, global energy consumption will rise by 36% at a 1.6% growth rate, where fossil fuel-based hard energy has a greater contribution (88%) to total energy supply [1]. More utilization of hard energy accumulates major greenhouse gases (carbon dioxide (CO<sub>2</sub>), methane (CH<sub>4</sub>), and nitrous oxide (N<sub>2</sub>O)) concentration to nature [2]. Global CO<sub>2</sub> emission was 19,074.50 million tons throughout the world in 1981, and it has continued to increase 34,032.70 million tons in 2017 [3]. This trend will rise by 85% within 2040 [4]. Bangladesh is not free from such circumstances as it largely depends on hard energy (furnace oil: 20.44%, diesel: 7.80%, power import: 4.07%, coal: 2.04%, hydro: 1.88, natural gas: 62.20% and other: 1.60) for power generation and transmission [5].

In Bangladesh, power generation is mostly dominated by indigenous natural gas (62.20%), which is now showing a depleting trajectory because of its faster rate of utilization by 300% from 1990 to 2019 [6]. Bangladesh has been experiencing a severe energy crisis for about three decades and is third among the top twenty countries where people lack electricity [7]. The energy crisis is terrible in rural Bangladesh. Only around 30% of rural households have interrupted access to grid-connected electricity [8], while about more than 75% of the total population (equivalent to 164.20 million in 2012) in the country live in the village. Almost 58% of rural families in the country are basically “energy poor” (*i.e.*, utilization of modern energy services per capita is

very low), with a shortage of access to reliable and basic hard energy facilities [9]. In recent years, quick rental power plants have been established to minimize the immediate power shortage, responsible for raising the price of electricity in the country [10]. Like the shortage of access to grid-connected electricity, rural households have almost no natural gas access through pipelines for cooking. Environmentally friendly eco-development (desirable and soft change for a human social group, which is held to be not only better, but in economic and ecological equilibrium) practices, policies, and programs are highly required to overcome this situation. Economically equitable, socially ennobling, and environmentally balanced issues for sustainable rural development, low carbon growth, proper use of soft energy, and long-term adjustment of climate change are the main features of eco-development.

Rural Bangladesh is a source of soft energy (energy from renewable resources) such as biomass resources (*e.g.*, animal manure, crop residues, and kitchen and green wastes), harnessing solar power, hydro-potential, and wind. Soft energy guided eco-development ensures a low carbon society, job creation, and electricity demand in rural Bangladesh. The absence of appropriate design and mismanagement of eco-development may hamper the initiatives and activities for green growth, low carbon society, and renewable energy in rural Bangladesh and fail to meet goal 7 (affordable and clean energy) of SDG. There is no provision of existence value soft energy (the main building block of eco-development) in rural Bangladesh. Consequently, agencies, NGOs, and the government have least success to create a resource base for renewable energy. The above statement provides a background to the origin of thoughts and motivation to carry out this research.

To a certain extent, the existence value of soft energy, government, and institutional support to implement, but little is aware of the intensity of social preferences in this field. What are the rationales behind

\*Government Edward College, Pabna-6600, Bangladesh.

<sup>+</sup>Bangladesh Embassy, Bangkok-10110, Thailand.

<sup>1</sup>Corresponding author;

Tel: + 88 01717 278232; + 88 01776 196953.

E-mail: [vaskoriqbal@gmail.com](mailto:vaskoriqbal@gmail.com)

the *WTP* for soft energy instead of hard energy (energy from relatively inconsequential fossil fuels)? How much are village people willing-to-pay (*WTP*) for the utilization of soft energy? This paper may be the first attempt to answer these questions using a contingent valuation (*CV*) approach. Based on the research questions, the objective of this study has two folds: to grab those affecting household preference (socio-economic-demographic characteristics) for the provision of the utilization of soft energy; and to quantitatively estimate the non-use value of soft energy by assessing how much the rural households are willing-to-pay for it.

This study addresses new insights to the existing literature on the non-use value of soft energy by providing empirical evidence in the context of basic or explorative research. The study's findings can be used in cost-benefit analysis in a larger field of soft energy since the study considers a pecuniary value to the household preferences for science by using effective methods suggested by welfare economics. Indeed, the major advantages stemming from soft energy cover the creation of knowledge outputs, externalities, capital formation, the cultural impact of the outreach, and service provision only to capture the use-value or option value. The non-use value's benefits should also be considered to estimate the overall economic value [11]. It seems to examine *WTP* for scientific discovery.

## 2. LITERATURE REVIEW

The dumped household organic waste creates emission from methane and enhances the greenhouse gases (GHGs) in rural Bangladesh. Emissions of GHGs lead to unprecedented transformations in the earth's climate, and long-term environmental changes [12]. Energy is consisting of the exploitation of energy sources, energy conversion, and power generation. Organic waste and solar will be a potential source of electricity generation and develop an eco-development mechanism. Eco-development is the best platform for climate change mitigation. The provision of soft energy in eco-development has no insoluble problems, but hard energy options involving reliance upon fossil fuels and uranium can, on the one hand, lead to short term benefits while, on the other, they store up great difficulties in energy supply for the future [13]. Eco-development provides external benefits and is essential to assess green growth practices to justify climate change mitigation actions in the energy sector [14].

Domestic soft energy implementation has gained momentum in China, India, Nepal, Vietnam, Cambodia, Japan, South Korea, and Thailand [15]. From 2007 to 2012, the number of soft energy usage households has increased in China and India. In China, the number of households increased from 26.50 to 42 million, and in India from 4 to 5 million [7]. Soft energy could provide an alternative energy source essential to mitigate energy shortage and ensure long-range energy planning [1]. Turkey utilizes greenhouse heating for improved

agricultural productivity by biogas, solar, and ground source heat pump hybrid system. Bangladesh is endowed with a plentiful supply of soft energy. Out of the various renewable sources, solar and biomass, and to a limited extent, wind and hydro-power are effectively used [16]. Installation and utilization of soft energy at household levels are determined by income, level of education, occupation, gender, age, household composition, social mobilization, institutional support, and religious status are the important determinants of utilization of soft energy at household level [17].

The *CV* technique is suitable for a quantitative approach for presenting consumer preferences and choice of a good and service. The *CV* technique elicits tangent stated preference over different hypothetical alternatives and has significant advantages over the *WTP* [18]. The *CV* and *WTP* have successfully applied to environmental and resource economics, energy economics, health economics, and ecological economics [19]. The measure of *WTP* is essential to evaluate the economic efficiency of soft energy. For proper implementation of soft energy in India through eco-development mechanisms people are prepared to pay for low carbon growth [20]. Based on a random effect meta-analysis of 30 studies [21] makes a summary of *WTP* for renewable energy use and develops a *CV* questionnaire to get respondents' perception on soft energy and its effectiveness.

Many studies have focused on the effectiveness of soft energy-related eco-development for low carbon society, energy efficiency and uninterrupted energy supply, country experience, and soft energy determinants. However, very few studies covered the effectiveness of soft energy in rural Bangladesh. This study may be the first attempt to explore the factors related to implementing soft energy in rural society, examine its effectiveness, and develop appropriate soft energy policies.

## 3. THEORETICAL MOTIVATION

### *The Eco-Development*

Traditional development models delude low-income countries on two major counts. Firstly, low-income countries hold out material improvements attained through economic growth lead to develop expropriation of existing natural resources and overexploitation of labor; secondly, most of the poor countries are mollified by antidotal aid aim to combat disease, disaster, malnutrition, food insecurity, and illiteracy. These traditional models always ignore flows of non-existent natural resources that have more significant potential for overall well-being.

The improved society belonging to Northern nations is generally known as a consumer society. This society motivates low-income countries towards growth and creates inequality within and between nations [22]. A number of poor nations are now exploiting for their growth and generating the selfsame dividend society.



The degraded resources and pushed their frontiers too far and fell into bureaucratic disorder. Thus, it can be said that bureaucratic disorder, resource degradation or depletion, and frontiers' mismanagement are significant outcomes of growth in selfsame dividend society [13]. Parasitic selfsame dividend society is treated like a shadow of modern consumer society. This society always tries to maintain the rate of consumption without consideration of the environment, ecosystem, biodiversity, and nature. It is essential to introduce an alternative attitude to development (highlighted more in regional human progress than national economic growth) in low-income societies or nations to mitigate this unusual practice's intensity. Eco-development can ensure regional human progress, equity, environmental balance, diversified culture, and social harmony through mutual respect, collective beliefs, and cooperation [23].

Two terms economic and environmental prospects constitute eco-development. It describes soft change for a human social group and works for better economic, social, and ecological equilibrium [24]. It works against resource depletion and advocates a balance between human and natural resources like air, land, wind, water, and forestry. It is the best fitting approach to optimize the balance between the number of populations, locally available resources, and culturally desired lifestyles [25]. It offers a rational, humanitarian, and democratic foundation for the government [13]. Proper utilization of eco-development can meet our fundamental rights, such as clothing, shelter, nutrition, and decent life [26]. Eco-development brings numerous benefits, and it can be directed by organizational, and political, operational, and administrative points of view [27]. Establishing an ideological commitment, sharpening political and administrative integrity, and attaining international parity are induced mostly by the organization [38]. Likewise, alleviate poverty and hunger, develop low carbon society and green growth, eradicate disease and misery, clean up urban squalor, balance the number of humans with existing resources, conserve resources and protect the environment are associated with political, operational and administrative initiatives [28].

A higher degree of jointness of economic and environmental issues through the eco-development model can align resource conservation and protection of the habitat, offering human well-being, and construct a better future for our grandsons. Eco-development is essential to utilize resources properly in the terrestrial platform, solar incidence, oxygen, carbon dioxide, and water. Eco-development has a greater relationship platform with such resources for energy conversion. Reference [13] notes that "empirically the pursuit of eco-development rests on a recognition of the constraining influences of the law of entropy, most particularly the long-term consequences arising from the disordering of earthbound energy resources". Wise and proper use of these resources can protect the ecological system and less emission and develop a low carbon society. Among all resources, renewable resource is

suitable for generating soft-energy in terms of its origin, features, applicability, and future.

Every society can convert renewable resources into soft-energy such as solar power, tidal and wind offshoots, hydro and vegetable, alcohol, or biomass. On the contrary, hard energy options like fossil fuels, uranium, gas, and coal from the non-renewable can, on the one hand, lead to short-term benefits while, on the other, they accumulate great difficulties in energy supply for the future. For better policy options, it is essential for valuing soft energy through *WTP* in rural Bangladesh.

There are a large number of valuation approaches to environmental goods and services. The most common are the contingent valuation approach, conjoint analysis, opportunity cost method, pairwise comparison approach, benefits transfer approach, hedonic pricing approach, and travel cost method [12], [29]. Existing studies suggest that *CV* is the best fitting approach for valuing soft energy [30]. Since the estimation process of the existing value of soft energy is still in infancy, this study decided to consider the *CV* approach rather than adopting any of the approaches mentioned above because of their limited capacity to value in the soft energy context. The following section will cover the nature of *CV* for valuing the soft energy in rural Bangladesh.

### *The Contingent Valuation Method*

The traditional theory of demand and welfare economics state that the value of a good arises from its use or utility. Nevertheless, the sixties environmental economists' forum argued that there might be a value arising from non-use of the pure existence of environmental goods [31]. According to [32], non-use value can be classified into three main categories: the bequest or altruism value, the option value, and the existence value. The quasi-option value is another form of non-use value, which is closely associated with the option value. The option value is applicable when predicting a little use of good in the future but not use it at the current time. If it is not possible to predict the use or irreversibility of good at present, then quasi-option value is more applicable [33]. The nature and feature of existence value are different from a bequest, option, and quasi option values. The existence value generates from the utility and perception of the existing good, even without any expectation or unpredictable use [34]. The existence value stated preference data, and contingent valuation is highly correlated with each other and essential to measure the non-use valuation of environmental goods and services through willingness-to-pay (*WTP*).

Stated preference data and *CV* appear to date back to the early 1960s when Davis (1963) conducted a study that highlights the value to retreaters of the Marine (United States) woods [35]. During the 1980s and 1990s, the *CV* method became more popular for valuing environmental goods. [36] Provide guidelines of the *CV*

method, which were supported by an authoritative panel of experts (six distinguished economists and survey researchers, including two Nobel laureates) of the National Atmospheric Administration (NOAA). The NOAA panel concluded that CV could be useful for supporting the non-market valuation of environmental goods, services, government regulatory actions, provision of public goods, health care service, and cultural economics [35]. The NOAA supported guidelines for the CV have then been broadly refined, adapted, and implemented to the non-market valuation essential for changing scenario and policy formation.

The stated preference data involve exploring an individual's WTP for good by developing a set of questions followed to the CV method in terms of stated choices or preferences directly to the individual [37]. In a CV, a respondent is asked to imagine some situation that is typically outside the respondent's experience, speculate on how s/he would act in such a situation [38]. More specifically, a respondent should be asked to state only 'yes' denoted by 1 or 'not' denoted by 0 to the proposed payment for existing environmental goods or services. The superscript 0 presents the current scenario, and 1 refers to an improved scenario. The CV is a helpful approach to develop a questionnaire and measure WTP or shadow price (maximum bid that a respondent is ready to accept and would like to pay for environmental goods or services) [39]. In this viewpoint, Equation 1 can also be written as:

$$CV_i = e_i \int_{q^0}^{q^1} \pi(F^1, x, U_i^0) dq \quad (1)$$

WTP is elicited through the CV method because of the unobserved nature of the shadow price function  $\pi_i(F, x, U_i) = -\delta e(F, x, U_i) / \delta x$ .

According to the random utility model, if respondent's income in the utility function is  $Y_i$  and the bid value for any environmental goods is  $h_i$  for the individual  $i$ , a respondent will be willing to pay  $h_i$  (because of rises utility or satisfaction from  $x^0$  to  $x^1$ ) if

$$U_1(y_i - h_i, z_i, \varepsilon_i) > U_i(y_i, z_i, \varepsilon_i) \quad (2)$$

Equation 2 implies that respondents will participate in a bidding game for WTP if they are better off with the payment and provide the facility for the goods or services [37],[40]. This proposition gives the probability of a respondent who has a positive attitude towards those goods or services, written as:

$$\Pr(\text{positive attitude}) = \Pr\{U_1(y_i - h_i, z_i, \varepsilon_i) > U_i(y_i, z_i, \varepsilon_i)\} \quad (3)$$

The utility function of an individual is strongly and additively separable into a deterministic and random component [49] and can be written as:

$$U(y_i, z_i, \varepsilon_i) = U(y_i + z_i) + \varepsilon_i \quad (4)$$

Assume that the deterministic or non-stochastic segment of the utility function is

$U_i = \alpha_i z_i + \beta(y_i - h_i)$  and the stochastic segment is the error term ( $\varepsilon$ ). The utility difference is measured as:

$$U_i^1 - U_i^0 = (\alpha_i z_i + \beta h_i) \quad (5)$$

$$\Pr(\text{positive attitude}_i) = \Pr(\alpha_i z_i - \beta h_i + \varepsilon_i) > 0 \quad (6)$$

The common objective CV approach is the derivation of measures designed to determine the amount of money where participants are willing to forfeit to obtain benefits from the undertaking of some specific action, and such measures are known as WTP [41]. Based on the existing literature, the study argues that the management of eco-development is not only to the government's actions and efforts. It also requires collective efforts or actions which need data from different stakeholders to measure WTP for proper management of soft energy. Improper application of CV and its guided questionnaire may hamper the whole survey and data collection process. The CV guided questionnaire should design to give background information on the problem, describe the "good" in question, elicit WTP, and collect information on the respondent, such as age, income, level of education, marital status, religious status, gender, social mobilization, and household composition [35]. Asking about the WTP for improving eco-development in the energy sector is never easy. Every researcher should follow a few characteristics of NOAA guidelines for conducting the CV survey. A successful CV study has six components which are essential to measuring WTP: define market scenario (i.e., the information to be conveyed to a respondent), choice elicitation method (e.g., direct question, bidding game, payment card, and discrete choice or referendum or single-bounded dichotomous choice), design survey administration (e.g., mail, internet, telephone, and in-person), design sampling (i.e., the first is to choose the group from which to draw the sample, and the second is to draw the random sample), design of experiment and, estimate WTP [42].

The NOAA guidelines suggest that a single referendum method is the best method to ask respondent 'yes' or 'not' to base bid or payment value to elicit WTP for a particular environmental good or service [43]. The follow-up question's bid level should be greater than the base payment offered if the answer to the base payment question is 'yes'; otherwise, the follow-up procedure is not continued. The bidding game method is more efficient than the single referendum method [44]. Besides, the single referendum elicitation format is highly vulnerable to anchoring effects [45]. For the proper empirical investigation, and questionnaire development, the CVM requires Focus group discussion (FGD), survey, and sampling. The following section covers the brief discussion of FGD, the CV questionnaire, and sampling techniques.



#### 4. METHODS

##### **Focus Group Discussion (FGD) and Variable Selection**

Customization is an issue in the selection of the pecuniary attribute and its level. Under this process, it should attempt to make the choice alternative more realistic by relating the pecuniary attribute and its level. There is a rule of thumb that each higher pecuniary alternative directly relates to its actual level proposed by FGD. The visibility levels could be set 15% higher than the proposed or actual level [46]. This study organized four FGDs, which consists of (7-8) participants of each occurred on 23-26 December 2019 at Char Dulai, Ataikanda, Hatgram, and Bonogram in Sujanagar, PabnaSadar, Bhangura and Chatmohar sub-districts under Pabna district of Bangladesh. The first objective of FGD was to set a base price for the service of soft energy, and it was fixed at Tk. 3,000 per month, and it will be 36,000 per year. The value presented in local currency (BDT: Bangladeshi Taka), equivalent to US\$ using a conversion rate of BDT equivalent to US\$ using a conversion rate of BDT 1 to US\$ 0.012 corresponding to March 2020. The second objective was to detect the desirable services from soft energy for rural households. The entire participants preferred solar pumps for irrigation, power generation from solar panels for the operating fridge, watching television, lighting room, charging electronic gadgets, roadside solar lamps, and waste-based biogas transmission facilities for cooking.

In this study, the monthly payment attribute for the utilization of soft energy is selected based on the findings from FGD. The reviewed literature helped us select variables (e.g., age, monthly income, household composition, education, and social mobilization) and develop the questionnaire. According to a systematic review of factors affecting the utilization of soft energy in rural Bangladesh, lack of social mobilization could be facilitators or barriers to utilizing soft energy in Rural Bangladesh [47]. More specifically, other studies found that lack of social mobilization becomes a barrier to developing a low carbon society through soft energy [48]. Besides, another two studies suggested that age, income, household size, and education level in the Philippines, Japan, South Korea, and Taiwan play a significant role in developing soft energy [49],[50].

##### **The CV Questionnaire**

This study carried out a CV survey to fulfill its objectives (identify the independent variables potentially affecting respondents' WTP for the service of soft energy, and measure the expected WTP as a provider of scientific discovery) that comes from the methodological insights of the CV related literature.

The pre-test was conducted to validate and understand the experimental setup where twenty-five respondents (seven farmers, four small traders, three rickshaw pullers, five service holders, four community leaders, and local government representatives, and two

fishers) took part in the pre-test. These fifteen respondents were omitted from the main survey results. The pre-test results' assured that the proposed attributes and their associated levels were significant and relevant in terms of validity of respondents' experiment and understandability.

The common objective of the CV survey is the derivation of measures designed to determine the amount of money where participants are willing to forfeit to obtain benefits from the undertaking of some specific action and such measures are known as WTP [51]. The study assumes that initiative towards soft energy is not only to the actions and efforts of the government. It also requires collective efforts or actions requiring data from different households to elicit WTP for proper empirical investigation. Improper application of the CV survey may hamper the whole survey and data collection process. This study was strictly followed by NOAA guidelines to develop and design questionnaires to avoid such a situation. The questionnaire has three sections. Section one highlighted the background knowledge, information, and awareness of respondents about soft energy. Open-ended and binary choice questions were included to identify the respondents' preference, desire, ability, and interest in soft-energy service. Besides, a brief description of the importance of soft energy was also included in this section. Section two contained personal information such as respondents' age, monthly income, household composition, years of schooling, and social mobilization provision. Section three has included questions to elicit the WTP through the bidding game method. The WTP is elicited in two ways [33]. First, respondents are asked about their willingness to offer a single lump-sum payment with three possible alternative answers: 'yes', 'no', and 'do not know'. Second, the WTP is asked in the form of an annual fixed contribution for 10 years. The study allows second options for soft energy because rural people of Bangladesh cannot pay more at a time and do not prefer long term contracts.

Respondents who completed the first session of the questionnaire were proceeding to the bidding game. Seven trained data collectors and professional interviewers conducted all survey interviews. Before starting the CV survey, the assigned data collectors meet face-to-face with the respondents and explain the imagery scenario of the proposed service from soft energy and the bidding game rules. The interview of respondents was taken care of for a long time. The data collectors did not indulge in any personal and irrelevant gossiping to avoid anchoring or influencing the respondents' answers. Besides, respondents' strategic behavior was tackled by ensuring the questionnaire's anonymity to reduce suspicious related to highly sensitive information [52].

##### **Sampling**

This study has chosen twenty villages of all sub-districts under Pabna district purposely for sample selection, but

the representative households were randomly sampled. For sample random samples (SRS), the minimum acceptable sample size,  $n$ , was determined by applying the following formula.

$$n \geq \frac{q}{p\alpha^2} \left[ \phi^{-1} \left( 1 - \frac{\alpha}{2} \right) \right]^2 \quad (7)$$

Estimated probabilities at a 95% level of accuracy and Z2 (calculated by Microsoft Excel) determine sample size 307 in the study area. Four villages (Chardulai, Dulai, Kumuria, and Vhabanipur) of Sujanagar sub-district, three villages (Ataikanda, Atguriapara, and Shanirdear) of PabnaSadar sub-district, three villages (Nayabari, Masundia, and Kaitola) of Bera sub-district, two villages (Hotgram, and Nowbaria) of Bhangura sub-district, two villages (Bagpur, and Kabarikhola) of Shanthia sub-district, one village (Dhanuaghata) of Faridpur sub-district, one village (Voroymary) of Ishwardi sub-district, two villages (Bonogram, and Jogtala) of Chatmohar sub-district, and two villages (Gokulnagar and Shibpur) of Atghoria sub-district were selected for sample selection.

All heads of households (permanently live in these villages and have land, and business, occupation) got eligibility to be respondents. The head of the household (father or elder son or in certain case mother) is defined as the person making the major economic, social, and household decisions irrespective of age [53]. Out of estimated 338 respondents, 307 (90.82%) respondents were agreed to participate in the CV survey, and the rest 31 (9.17%) respondents were refused the request to participate in the survey and conjoint experiment. Among all respondents, 157 (51%) were farmers, 7 (2%) were fishermen, 106 (35%) were businessmen, small traders, and shopkeepers and the rest 37 (12%) were service holders. For the proper empirical investigation, the author conducted FGD and pre-test along with other data collectors. The household surveys were conducted in twenty villages in all sub-districts of Pabna district from 11 to 29 January 2020. On average, two days were spent in each village to collect data.

### Framework for Measuring WTP

A zero-inflated ordered logistic regression model and a standard multinomial logistic model are used to examine the independent variables affecting respondents' WTP [33]. The first regression model is suitable for annual fixed contribution to soft energy, while the second regression model is applicable in a single lump-sum payment for utilization of soft energy. In the study, this study applied a zero-inflated ordered logistic regression model because of consideration of annual fixed contribution to soft energy at the village's household level. Besides, WTP flows a discrete ordered variable, including the zero value. As demonstrated by [54], the traditional ordered logistic regression model has a narrow scope in explaining zero observations. Existing studies suggest that a zero-inflated model by applying a double combination of a split logit model and an ordered

logit model is the best-fitted model to overcome this situation [33]. For simplification, suppose a group of respondents is categorized into 'no' or zero preferred option (they are not willing to pay), and 'yes' or 1 preferred option (they are willing to pay) and their functional form of WTP is written as  $WTP_i$  ( $i=0,1,\dots,N$ ). Under this procedure, it is possible to examine the binary decision to be positive or negative towards WTP in the first stage. Besides, it is also possible to examine the probability of falling in one of the bid categories conditional on being WTP [58]. The binary decision to pay is structured with a logit model is given as follows:

$$P_i^* = X_{1i}\gamma + u_i \quad (8)$$

The observed binary variable for being WTP ( $P_i$ ) relates to the latent variable ( $P_i^*$ ) and can be written as:

$$P_i = \begin{cases} 1 & \text{if } P_i^* > 0 \\ 0 & \text{otherwise} \end{cases} \quad (9)$$

Probability of paying is the combination of Equations 8 and 9 and can be expressed as:

$$\Pr(P_i = 1) = \Lambda(X_{1i}\gamma) \quad (10)$$

and its likelihood function is given by:

$$L(\gamma/P_i, X_{1i}) = \prod_{P_i=0} [1 - \Pr(P_i = 1)] \prod_{P_i=1} \Pr(P_i = 1) \quad (11)$$

Let  $WTP_i$  be an outcome variable measuring the level of the proposed bids and take on integer values from 0 to  $J$ . The variable  $WTP_i$  takes the value of zero for those respondents who chose the 'no' option ( $P_i=0$ ). Positive values can only be observed conditional on  $P_i=1$ . The joint likelihood of observing the entire sample takes the following form:

$$L(\theta/WTP_i) = \prod_{P_i=0} [1 - \Pr(P_i = 1)] \prod_{P_i=1} \Pr(P_i = 1) \Pr(WTP_i/P_i = 1) \quad (12)$$

The conditional density  $P_r(WTP_i/P_i = 1)$  can be perfectly handled by an ordered logit model [55]. In our proposed model, each respondent presents the strength of his preferences in terms of the level of bid chosen. Although the choices or preferences will vary continuously in the traditional utility theory, the expression of respondents' preferences is given in a discrete outcome on a scale with a limited number of choices. Hence, our proposed model is constructed around a latent regression of the following form:

$$WTP_i^* = X_{2i}\beta + \varepsilon_i \quad (13)$$

The variable  $WTP_i$  coincides to the latent variable ( $WTP_i^*$ ) according to the following rules:

$$\begin{aligned} WTP_i &= 1 & \text{if } WTP_i^* \leq \tau_1 \\ WTP_i &= j & \text{if } \tau_{j-1} < WTP_i^* \leq \tau_j \quad j = 2, \dots, J-1 \\ WTP_i &= J & \text{if } \tau_{j-1} < WTP_i^* \leq \infty \end{aligned} \quad (14)$$

The conditional distribution of  $WTP_i$  given  $P_i=1$  and  $X_{2i}$  and the likelihood function of this sub-sample are given by the following form of equations:

$$\Pr(WTP_i = j/P_i = 1) = \wedge(\tau_j - X_{2i}\beta) - \wedge(\tau_{j-1} - X_{2i}\beta) \quad (15)$$

$$L(. / WTP_i, X_{2i}) = \prod_{j=1}^J [\wedge(\tau_j - X_{2i}\beta) - \wedge(\tau_{j-1} - X_{2i}\beta)]^{WTP_{ij}} \quad (16)$$

Equation 12 should get top priority to estimate. From the statistical view point, it expresses the joint distribution of the random variables  $WTP_i$  and  $P_i$  conditional on the independent variables contained in  $X_{1i}$  and  $X_{2i}$  with the variance-covariance matrix of the bivariate distribution of the error term  $\xi \equiv [u_i \ \varepsilon_i]'$  defined by the following matrix:

$$V(\xi) = \begin{bmatrix} \sigma_\varepsilon^2 & \sigma_{\varepsilon u} \\ \sigma_{\varepsilon u} & \sigma_u^2 \end{bmatrix} \quad (17)$$

In this model,  $X_{1i}$  includes the explanatory variables which determine the 'yes' or 'no' decision towards  $WTP$  (the participation Equation 10) and  $X_{2i}$  which influence the level of the bid chosen (the level Equation 15). Naturally,  $X_{1i}$  is an informative set contained in  $X_{2i}$ , and in that sense,  $X_{1i}$  and  $X_{2i}$  are identical where covariance between  $u_i$  and  $\varepsilon_i$  take zero value. In this viewpoint, the study estimates Equations 10 and 15 separately. More specifically, the study estimates Equation 10 using the entire sample and Equation 15 is using to estimate the sub-samples. This procedure is essential for answering the first research question of the study.

The regression model in Equation 13 is suitable for estimating the existence value of all environmental goods [56]. We apply this model to provide an answer to the second research question. Suppose the outcome variable of interest towards utilization of soft energy,  $S_i$  ( $i=0,1$ ) is binary.  $S_i = 0$  identifies respondents who would not be  $WTP$  for the service from soft energy whereas,  $S_i = 1$  describes respondents willing to pay for the proposed bid. Each respondent has an indirect utility function of the form  $V(M; Y_i; Z_i)$ . During the survey, each respondent has options: to answer 'no' which

implies that respondent has no interest in soft energy and under this scenario, all of his income ( $Y_i$ ) remains same, and to choose 'yes' which implies that respondent has an interest in soft energy and under this scenario, all of his income has reduced. Following the latter option, it is possible to write the respondent's indirect utility function as follows:

$$\delta V_i^* = V(1; Y_i - A; Z_i) - V(0; Y_i; Z_i) + v_i \geq 0 \quad (18)$$

Empirically, the probability of offer (A) from respondents is approximated with a binomial model given as follows:

$$\Pr(S_i = 1) = \wedge(\delta V_i^*) = \wedge(\alpha + A\beta_1 + Y_i\beta_2 + Z_i\beta_3) \quad (19)$$

It is possible to get the expected value of  $WTP$  by numerical integration after completion of the estimation process of Equation 19. The truncated mean  $WTP$  (integrating from 0 to maximum bid) is the most appropriate method because it satisfies theoretical constraints (the upper limit of the  $WTP$  is not infinity but something less than income) [57]. By using this method, the value of the maximum bid ( $A$ ) has to be assigned to all recorded  $WTP$  above ( $A$ ). The mathematical form of truncated mean  $WTP$  can be written as:

$$\begin{aligned} E(WTP) &= \int_0^{Max.A} \wedge(\delta V_i^*(A)) \delta A \\ &= \int_0^{Max.A} [1 + \exp(-(\hat{\alpha} + A\hat{\beta}_1 + Y_i\hat{\beta}_2 + X_i\hat{\beta}_3))]^{-1} \delta A \quad (20) \\ &= \int_0^{Max.A} [1 + \exp(\hat{\alpha} + A\beta_1)]^{-1} \delta A \end{aligned}$$

## 5. RESULT

### Descriptive Statistics of the Variables

Based on the collected data obtained from surveys in twenty villages of Pabna district, basic descriptive statistics of major variables are calculated (see Table 1 for more details).

**Table 1. Brief descriptive statistics of the variables.**

Variables	Mean	Minimum	Maximum	Standard deviation
Age (years)	35.42	25	75	13.13
Monthly income (Tk.)	22,617	5,000	75,000	1243.14
Education (years of schooling)	5.33	0	17	5.09
Household composition (family member)	5.03	4	11	2.79
Bidding price for 'yes' case	2,357.07	2,500	1,800	27.34

(Source: Authors' calculation based on survey data, 2020)

A total of 307 villagers participated in the survey, where a major portion was covered by male respondents (98%) and the rest 2% was covered by females. About 203 (66.12%) respondents argued that soft energy could play an important role in developing a low carbon society and ensuring energy efficiency, but 104

(33.87%) respondents were not interested in paying for service from soft energy due to low income, faith and trust, and effective utilization of collected funds. All respondents strongly agreed that they did not get access to the national grid for electricity. Table 2 depicts the summary statistics (SED) of the study. The average age



and monthly income of the respondents were calculated at 35 years and Tk. 22,617 respectively. About 133 (43.32%) respondents passed secondary school certificate (SSC) examination, higher secondary certificate (HSC) examination, and above, 98 (31.92%) respondents had completed primary education, and the rest of 76 (24.75%) respondents were illiterate. The average year of schooling was estimated at 5.33. The entire respondents believed that social mobilization could enhance the rural energy sector by soft energy. The monthly minimum bid was fixed at Tk. 1,800, and 182 (59.28%) respondents gave consent to pay this minimum amount or soft energy. Besides, the monthly maximum bid was fixed at Tk. 2,500, and 53 (17.26%) respondents agreed to pay this amount for soft energy. The monthly mean bidding price was calculated at Tk. 2,357.07 or US\$: 27.81. The majority of the villagers have five family members.

### Results of Models and the Truncated Mean WTP

Table 2 outlines the estimates of ordered logit model conditional on the sub-sample of respondents (Equation 15) and marginal effects of minimum and maximum paying groups for soft energy.

The signs, significance, and magnitudes levels of the estimates suggest that respondents' preferences were robust. All estimated coefficients are statistically significant at 1%, 5%, and 10 % levels. The negative sign of monthly income is negatively correlated with the level of *WTP* for soft energy. Economic theory, the structure of the question, and the household levels collected data can assist us in interpreting this surprising result. Economists argue that giving hypothetical services as a function of income is non-linear but has a U-shaped pattern-people in the lowest and highest income groups. This relationship persists even when accounting for additional services associated with income [58]. Likewise, the negative sign of payment derived from bid price is negatively associated with the *WTP* for soft energy. The higher price can shrink the scope of soft energy utilization and vice-versa, which can be supported by the traditional theory of demand. Finally, the Taos ( $\tau$ ) parameters refer to the thresholds used to differentiate the adjacent levels of the outcome variable (*WTP*). The significant signs of all Taos confirmed the justification of maximum and minimum bid for soft energy. Moreover, the likelihood ratio tests in the models confirmed that the explanatory variables' variation explains a good proportion of the variability in the outcome variable. Summing up, our empirical

analysis did not show significant differences between the independent variables associated with the outcome variable (*WTP*).

The estimated results of the logit model for all samples are presented in Table 3. As expected, the estimated coefficient on the bid was found negative and statistically significant. Monthly income has significantly impacted on the probability of 'yes' for *WTP* and the positive sign. The goodness of fit (McFadden *R*<sup>2</sup>) ensures that 34.1% of observations were correctly allocated to predict either 'yes' or 'no' indicating a good fit to the collected data.

Like the sub-sample case in Table 2, all sample cases' SED characteristics play a significant role in utilizing soft energy in rural Bangladesh. The payment stands out as the major burden affecting the probabilities to prefer soft energy. The preference is more sensitive to a higher payment for service from soft energy than a lower payment. This result confirmed the findings of previous studies [59],[60], and it was also consistent with the self-reported reasons why respondents did not prefer the provision of soft energy. The value of McFadden *R*<sup>2</sup> (goodness of fit) of all models imply that the total variation in the outcome variable can be explained by the variation of all variables of the models.

This study further explored the distribution of respondents' mean *WTP* for soft energy utilization at the household level. The result of the truncated mean *WTP* from Equation 20 was calculated by the significant coefficients of intercept ( $\hat{\alpha} = -0.003$ ) and the monthly payment ( $A = -0.327$ ) of the logit model for all samples, monthly mean bidding price 27.81\$ and 0 for no interest to pay for soft energy. The mean bidding price was placed at the upper limit and 0 was placed at the lower limit in the integral. The estimated value of truncated mean *WTP* is given as follows:

$$E(WTP) = \int_0^{2357.07} [1 + \exp(-0.003 - 0.327A)]^{-1} \delta A$$

$$= \text{Tk. } 2177.60 \text{ or US\$ } 25.69$$

The lower value of truncated mean *WTP* compared to general mean *WTP* does not necessarily imply low demand for soft energy, as the findings from  $E(WTP)$  illustrate potential demand for soft energy in rural Bangladesh and ensure eco-development. The empirically tested evidence generated by this study supports the findings of [47],[50].

**Table 2. Regression results of sub-sample survey.**

Variable	Model 1 (no for WTP)		Model 2 (yes for WTP)		Marginal effects for model 2			
	Coefficient	P-value	Coefficient	P-value	j= Tk. 1,800	P-value	j= Tk. 2,500	P-value
Age	0.217*** (0.322)	0.000	0.035*** (0.032)	0.000	0.002*** (0.423)	0.000	0.007 (0.452)	0.109
Monthly income	-0.032* (0.089)	0.102	-0.001*** (0.424)	0.000	0.128*** (0.067)	0.000	-0.241 (0.976)	0.190
Household composition	0.002 (0.471)	0.213	0.217* (0.521)	0.104	0.243 (0.001)	0.218	0.562 (0.037)	0.065
Education	0.001 (0.560)	0.110	0.235*** (0.472)	0.001	0.187 (0.732)	0.107	0.289 (0.064)	0.287
Social mobilization	0.325 (0.007)	0.132	0.017** (0.532)	0.042	0.010*** (0.200)	0.000	0.459*** (0.004)	0.000
Monthly payment	-0.092*** (0.452)	0.000	-0.019** (0.002)	0.033	0.395 (0.127)	0.164	0.137 (0.485)	0.340
Constant	-0.098 (0.035)	0.163	-0.007 (0.452)	0.214				
$\tau_1$	-2.47** (0.009)	0.021	0.531* (0.009)	0.102				
$\tau_2$	-2.09*** (0.031)	0.000	0.836*** (0.031)	0.000				
Observations (n)	104		235		182		53	
McFadden $R^2$	0.271		0.421					
Log likelihood	-472.302		-501.923					
Likelihood ratio test	24.985		33.001					

Note. Robust standard errors in parentheses. \*\*\*, \*\*, \* denote significance at the 1%, 5%, 10% level (Source: Authors' calculation based on survey data, 2020)

**Table 3. Regression results of all sample surveys.**

Variable	Coefficient	P-value	dy/dx	P-value
Age	0.201*** (0.020)	0.000	-0.007*** (0.013)	0.000
Monthly income	0.235* (0.437)	0.102	0.034* (0.125)	0.104
Household composition	0.197*** (0.493)	0.001	0.005*** (0.054)	0.003
Education	0.055** (0.250)	0.035	0.012** (0.067)	0.023
Social mobilization	0.189** (0.594)	0.023	0.011*** (0.025)	0.000
Monthly payment	-0.327** (0.008)	0.031	-0.016*** (0.090)	0.000
Constant	-0.003*** (0.005)	0.000		
Observation	307			
McFadden $R^2$	0.341			
Log likelihood	-579.761			
Likelihood ratio test	57.285			

Note. Robust standard errors in parentheses. \*\*\*, \*\*, \* denote significance at the 1%, 5%, 10% level (Source: Authors' calculation based on survey data, 2020)

## 6. CONCLUSION

The objective of soft energy is to ensure a low carbon society and efficient utilization of energy. The economic case for soft energy includes the cost of energy, eco-

development, green growth, and building well-being and resilience. However, in rural Bangladesh, the effectiveness of soft energy remains far from satisfactory due to the lack of awareness or social

mobilization and not the consideration of households' ability to pay for the provision of soft energy under the existing market scenario condition.

Bangladesh is one of the most electricity deprived nations [47]. Despite the large potential for soft energy sources in Bangladesh, their contribution to the power generation remains insignificant. The existing so-called service from soft energy does not meet the demand for energy and goal seven of SDG because of its shorter coverage facilities, inappropriate policy framework, and institutional support. Adequate use of soft-energy is considered an indispensable component of a sustainable energy system. Age, monthly income, household composition, and years of schooling were found to be important contributors to improve the utilization practice of soft energy because they are affecting households' preference for the provision of the utilization of soft energy. Lower payment for soft energy utilization does not necessarily indicate low demand for soft energy. Values of truncated mean *WTP* for the provision of soft energy make a guarantee that it creates well-being for households and brings a substantial amount of revenues from the sector of soft energy. The interest of rural households towards soft energy can be increased if soft energy payment is cost-effective based on our proposed socio-economic-demographic factors. Hence, any policy aiming to undertake soft energy service is needed to consider these factors for effective management and implementation of soft energy and eco-development. The study findings can serve as policy inputs to the soft energy sector and eco-development and pave the way for undertaking similar projects.

#### NOMENCLATURE

$e_i$	=expenditure function
$F$	= bid value vector
$x$	= current situation of environmental goods
$U_i$	= level of satisfaction
$Z$	= vector of SED characteristics
$\alpha$	= vector of coefficients of SED
$p$	= true choice proportion of accuracy
$q$	= not true choice proportion of accuracy
$\Phi^{-1}(1 - \frac{\alpha}{2})$	= inverse cumulative distribution function
$P_i^*$	= latent outcome
$X_i$	= vector of exogenous variables
$\gamma$	= vector of parameters
$u$	= error term
$\wedge(.)$	= logistic cumulative distribution function of $u_i$
$WTP_i^*$	= propensity to be willing to pay
$X_2$	= vector of exogenous variables
$\epsilon_i$	= random disturbance term
$\tau_1$	= unknown thresholds
$WTP_{ij}$	= indicator variable (1 and 0)
$M$	= binary variable
$Y_i$	= income

$Z_i$  = vector of exogenous variables

$\delta V_i^*$  =latent variable

$\hat{\alpha}$  = estimated adjusted intercept

#### REFERENCES

- [1] Islam M.T., Shahir S.A., Uddin T.M.I., and Saifullah A.Z.A., 2014. Current energy scenario and future prospect of renewable energy. *Renewable and Sustainable Energy Review* 39: 1074-1088.
- [2] Shindell D. and C.J. Smith, 2019. Climate and air-quality benefits of a realistic phase-out of fossil fuels. *Nature* 573(7774): 408-411.
- [3] Bushra N. and T. Hartmann, 2019. A review of state-of-the-art reflective two-stage solar concentrators: Technology categorization and research trends. *Renewable and Sustainable Energy Reviews* 114: 109307.
- [4] Meyer I., Leimbach M., and Jaeger C., 2007. International passenger transport and climate change: A sector analysis in car demand and associated CO<sub>2</sub> emissions from 2000 to 2050. *Energy Policy* 35: 6332-45.
- [5] Sohag M.A.Z., Kumari P., Agrawal R., Gupta S., and Jamwal A., 2020. Renewable energy in Bangladesh: Current status and future potentials. In *Proceedings of International Conference in Mechanical and Energy Technology*, 353-363. Springer, Singapore.
- [6] Das A., Halder A., Mazumder R., Saini V.K., Parikh J., and Parikh K.S., 2018. Bangladesh power supply scenarios on renewable and electricity import. *Energy* 155: 651-667.
- [7] Khan M.E. and A.R. Martin, 2016. Review of biogas digester technology in rural Bangladesh. *Renewable and Sustainable Energy Reviews* 62: 247-259.
- [8] Goel S. and R. Sharma, 2017. Performance evaluation of standalone, grid connected and hybrid renewable energy systems for rural application: A comparative review. *Renewable and Sustainable Energy Reviews* 78: 1378-1389.
- [9] Barnes D.F., Khandker S.R., and Samad H.A., 2011. Energy poverty in rural Bangladesh. *Energy Policy* 39: 894-904.
- [10] Islam S. and M.Z.R. Khan, 2017. A review of energy sector of Bangladesh. *Energy Procedia* 110: 611-618.
- [11] O'Garra T., 2017. Economic value of ecosystem services, minerals and oil in a melting Arctic: A preliminary assessment. *Ecosystem Services* 24: 180-186.
- [12] Iqbal M.H., 2017. Economic benefits of an eco-town for slums in Dhaka city of Bangladesh: An application of discrete choice model. *Australian Academy of Business and Economics Review (AABER)* 3(2): 61-75.

- [13] Riddell R., 1981. *Ecodevelopment*. Hampshire: Biddles Limited.
- [14] Streimikiene D., Balezentis T., Alisauskaitė-Seskiene I., Stankuniene G., and Simanaviciene, Z., 2019. A review of willingness to pay studies for climate change mitigation in the energy sector. *Energies* 12(8): 1481.
- [15] Bolt P.J., 2011. Contemporary Sino-Southeast Asian Relations. *China: An International Journal* 9(2): 276-298.
- [16] Islam A.S., Islam M., and Rahman T., 2006. Effective renewable energy activities in Bangladesh. *Renewable Energy* 31(5): 677-688.
- [17] Demirbas M.F. and M. Balat, 2006. Recent advances on the production and utilization trends of bio-fuels: A global perspective. *Energy Conversion and Management* 47(15-16): 2371-2381.
- [18] Murphy R.O. and K.A. Ackermann, 2014. Social value orientation: Theoretical and measurement issues in the study of social preferences. *Personality and Social Psychology Review* 18(1): 13-41.
- [19] Alriksson S. and T. Öberg, 2008. Conjoint analysis for environmental evaluation. *Environmental Science and Pollution Research* 15(3): 244-257.
- [20] Tanveer M.R. and A. Kashyap, 2016. Solar energy in future: Energy of next generation. *Enverman's Science* 3: 23-37.
- [21] Bergstrom J., 1990. Concepts and measures of the economic value of environmental quality: A review. *Journal of Environmental Management*: 31 (3): 215–228.
- [22] Engle P.L., Fernald L.C., Alderman H., Behrman J., O'Gara C., Yousafzai A., and Iltus S., 2011. Strategies for reducing inequalities and improving developmental outcomes for young children in low-income and middle-income countries. *The Lancet* 378(9799): 1339-1353.
- [23] Jenkins T.N., 1998. Economics and the environment: a case of ethical neglect. *Ecological Economics* 26(2): 151-163.
- [24] Colby M.E., 1991. Environmental management in development: The evolution of paradigms. *Ecological Economics* 3(3): 193-213.
- [25] Abel C., 1993. Eco-culture, development, and architecture. *Knowledge and Policy* 6(3-4): 10-28.
- [26] Wang R. and J. Yan, 1998. Integrating hardware, software and mindware for sustainable ecosystem development: Principles and methods of ecological engineering in China. *Ecological Engineering* 11(1-4): 277-289.
- [27] Okech R.N., 2009. Developing urban ecotourism in Kenyan cities: A sustainable approach. *Journal of Ecology and the Natural Environment* 1(1): 001-006.
- [28] Hollander J.M., 2003. *The real environmental crisis: why poverty, not affluence, is the environment's number one enemy*. California: University of California Press.
- [29] Quah E. and T.S. Tan, 2019. Valuing the environment (Report No. 1012). Tokyo: Asian Development Bank Institute.
- [30] Fischhoff B., 1990. Psychology and public policy: Tool or toolmaker? *American Psychologist* 45(5): 647.
- [31] Weisbrod B.A., 1994. Collective-consumption services of individual-consumption goods. *The Quarterly Journal of Economics* 78(3): 471-477.
- [32] Bateman I.J., Carson R.T., Day B., Hanemann M., Hanley N., Hett T. and Pearce D. W., 2002. *Economic valuation with stated preference techniques: A manual*. London: Edward Elgar Publishing Ltd.
- [33] Catalano G., Cheri D., and Florio M., 2014. The non-use value of scientific discovery: Evidence from a pilot contingent valuation of the large Hardon Collider. *Preliminary working note produced in the frame of the research project "Cost-benefit analysis in the research, development and innovation sector"*, part of the EIB University Research Sponsorship Programme (EIBURS).
- [34] Walsh R.G., Loomis J.B., and Gillman R.A., 1984. Valuing option: Existence, and bequest demands for wilderness. *Land Economics* 60(1): 14-29.
- [35] Kolstad C.D., 2016. *Intermediate Environmental Economics*. Delhi: Oxford University Press.
- [36] Arrow K.J., Solow R.S., Learner E., Portney P., Rodner R., and Schuman H., 1993. Report of the NOAA-Panel on contingent valuation. *Federal Register*, 58(10): 4601-4614.
- [37] Chopra V. and S. Das, 2019. Estimating willingness to pay for wastewater treatment in New Delhi: Contingent valuation approach. *Ecology, Economy and Society-the INSEE Journal* 2(2): 43-74.
- [38] Grunert K.G., Juhl H.J., Esbjerg L., Jensen B.B., Bech-Larsen T., Brunsø K., and Madsen, C.Ø., 2009. Comparing methods for measuring consumer willingness to pay for a basic and an improved readymade soup product. *Food Quality and Preference* 20(8): 607-619.
- [39] Weldesilassie A.B., Fror O., Boelee E. and Dabbert S., 2009. The economic value of improved wastewater irrigation: a contingent valuation study in Addis Ababa, Ethiopia. *Journal of Agricultural and Resource Economics* 34(3): 428-449.
- [40] Dutta V., Chander S., and Srivastava L., 2005. Public support for water supply improvements: empirical evidence from unplanned settlements of Delhi, India. *Journal of Environment and Development* 14(4): 439-462.
- [41] Hensher D.A., Rose J.M., and Green W.H., 2010. *Applied Choice Analysis: A Primer*. New Work: Cambridge University Press.



- [42] Carson R., 1991. Constructed markets. In J.B. Barden and C.D. Kolstad, eds. *Measuring the Demand for Environmental Quality*. Amsterdam.
- [43] Hanneman W.M., 1984. Welfare evaluation in contingent valuation experiments with discrete responses. *American Journal of Agricultural Economics* 66: 332-341.
- [44] Alberini A., Kanninen B., and Carson R.T., 1997. Modeling response incentive effects in dichotomous choice contingent valuation data. *Land Economics* 73(3): 309-324.
- [45] Green D., Jacowitz K.E., Kahneman D., and McFadden D., 1998. Referendum contingent valuation, anchoring, and willingness to pay for public goods. *Resource and Energy Economics* 20(2): 85-116.
- [46] Bradley M., 1988. Realism and adaptation in designing hypothetical travel choice concepts. *Journal of Transport Economics and Policy* 22: 121-137.
- [47] Uddin S.N. and R. Taplin, 2008. Toward sustainable energy development in Bangladesh. *The Journal of Environment and Development* 17(3): 292-310.
- [48] Verbong G.P., Beemsterboer S., and Sengers F., 2013. Smart grids or smart users? Involving users in developing a low carbon electricity economy. *Energy Policy* 52: 117-125.
- [49] Bertheau P., Dionisio J., Jutte C., and Aquino C., 2020. Challenges for implementing renewable energy in a cooperative-driven off-grid system in the Philippines. *Environmental Innovation and Societal Transitions* 35: 333-345.
- [50] Chen W.M., Kim H., and Yamaguchi H., 2014. Renewable energy in eastern Asia: Renewable energy policy review and comparative SWOT analysis for promoting renewable energy in Japan, South Korea and Taiwan. *Energy Policy* 74: 311-32.
- [51] Baron J., 1997. Biases in the quantitative measurement of values for public decisions. *Psychological Bulletin* 122: 72.
- [52] Bohm P., 1972. Estimating demand for public goods: An experiment. *European Economic Review* 3(2): 111-130.
- [53] Iqbal M.H., Mahamud M.S., Rahaman M.M., and Islam A.T.M.F., 2014. Seasonal food insecurity in the drought prone northwestern region of Bangladesh: an econometric analysis. *Journal of International Development and Cooperation* 20: 49-59.
- [54] Harris M.N. and X. Zhao, 2007. A zero-inflated ordered probit model, with an application to modeling tobacco consumption. *Journal of Econometrics* 141(2): 1073-1099.
- [55] Green W.H., 2012. *Econometric Analysis*. New Jersey: Pearson International.
- [56] Cameron T.A., 1988. A new paradigm for valuing non-market goods using referendum data: Maximum likelihood estimation by censored logistic regression. *Journal of Environmental Economics and Management* 15(3): 355-379.
- [57] Duffield J.W. and D.A. Patterson, 1991. Inference and optimal design for a welfare measure in dichotomous choice contingent valuation. *Land Economics*: 225-239.
- [58] McClelland R. and A.C. Brooks, 2004. What is the real relationship between income and charitable giving? *Public Finance Review* 32(5): 483-497.
- [59] Abdullah S. and P. Mariel, 2010. Choice experiment study on the willingness to pay to improve electricity services. *Energy Policy* 38(8): 4570-4581.
- [60] Longo A., Markandya A., and Petrucci M., 2008. The internalization of externalities in the production of electricity: Willingness to pay for the attributes of a policy for renewable energy. *Ecological Economics* 67(1): 140-152.



[www.ericjournal.ait.ac.th](http://www.ericjournal.ait.ac.th)

## Small Windmill as Alternative Power Source for Bangladesh: a Feasibility Survey under Wind Speed Scenarios

Md. Anwarul Karim\*

**Abstract** – Wind energy is zero fuel consuming, environmentally friendly and cost effective alternative renewable power source. A survey of wind speed was conducted all over Bangladesh within different seasons in a year. A handmade small windmill was used to investigate the voltage generation, current generation and power generation with respect to the wind speed during March 2018 to September 2018 at Chittagong, Bangladesh. The experimental results from small windmill and the survey reports on wind speed especially in coastal areas of the country suggest that the wind energy can be an alternative power source for Bangladesh.

**Keywords** – energy, power generation, small windmill, survey, wind speed.

### 1. INTRODUCTION

It is proven all over the world that the windmill can convert wind into electricity and can be a cheap source of grid quality renewable energy. A 1MW grid quality AC power from wind energy costs about 10 times less than that of 1MW grid quality AC power from PV solar cells. Other renewable energy sources have limited scope and are costly. In the world the total installed capacity of wind energy is more than 1,300,000MW. Germany installed more than 30,000MW capacity of wind power plant. Neighbouring country, India also installed 12,000MW capacity of wind power plant. A wind energy power plant can convert wind into electricity in the range from 27% to 30% [1]. From the conversion rate, the wind energy power plant is technically feasible and commercially viable. But the wind energy is facing two major obstacles: 1) the speed of the wind does not remain constant at all. It fluctuates in every second. 2) it is also not available all hours in a day.

Among all renewable energy sources, wind energy is one of the most cost-effective and environmentally friendly sources [2]. Bangladesh has a coastal line of 724 km along the Bay of Bengal [3]. Due to large coastal belt along with wind speed in some regions, the potential of wind power is enormous here [4]. In Bangladesh, power generation is mostly dependent on natural gas, around 76.74% of electricity is being produced from domestic gas reserves [5] and this percentage of electricity generation uses 37% of total gas consumption [6], while demand for gas consumption is increasing by about 8% per year [5]. We are still far from the expected growth of renewable energy, *i.e.*, target 1000-1200 MW and currently produce about 2

MW [7]. Wind can be a major source of energy for Bangladesh, if accurately examined and utilized. Various studies [8]-[11] have been conducted on wind energy and its usefulness in coastal areas in Bangladesh; and they have discussed about the potential of small size wind turbines.

The current government of Bangladesh has given priority to develop renewable sources and wind energy is one of them. Bangladesh Power Development Board (BPDB) has taken up projects in different areas in the country to setup windmill for electricity generation such as Kutubdia Upazila, Cox's Bazar; Sonagazi, Feni; Sirajganj Sadar Upazila, Sirajgonj; Kalapara Upazila, Patuakhali; Maheshkhali Upazila, Cox's Bazar, Chakaria Upazila, Cox's Bazar *etc.* [12].

Among them, Kutubdia (1MW) and Feni (900Kw) are currently generating electricity from wind and supplying to consumers. The wind battery hybrid power plant which is installed at Kutubdia island is an experimental plant with 1 MW capacity. Bangladesh Power Development Board (BPDB) has installed 50 small wind turbines each having 20 kW capacity. This wind battery hydride power plant is successful in Bangladesh and producing the first grid quality, 11 KV or more. It supplies electricity 3 hours during daytime and 3 to 4 hours during night. This project has been running well for more than two years. The wind battery hybrid power plant is supplying 0.60 to 0.80 MWh electrical energy every day at 11KV. Presently, the Wind Battery Hybrid Power Plant (WBHPP) is supplying over 240 MWh electricity at Kutubdia Upazilla [13]. Kutupdia project during cyclone SIDAR was not damaged.

Moreover, there are agreements with private companies for four locations with potential wind speed in the coastal areas of Bangladesh. These locations are (1) Parky Saikat near Patenga, Chittagong; (2) Mognamaghat, Pekua, Cox's Bazar; (3) Muhuri Dam, Sonagazi, Feni; and (4) Kuakata, Patuakhali. These four sites are representatives of the entire coastal areas of Bangladesh. We have seen that the annual average wind speed in these four sites is more than 6.5 m/s. It is an

\*Department of Applied Chemistry and Chemical Engineering, University of Rajshahi, Motihar, Rajshahi 6205, Bangladesh.

<sup>1</sup>Corresponding author;

Tel: + 880721711106, Fax: + 880721750064.

E-mail: [makarim72@ru.ac.bd](mailto:makarim72@ru.ac.bd).

internationally accepted thumb rule that a site having annual average wind speed of 6.0 m/s or higher is feasible for harnessing wind electricity with commercial viability [3].

In Bangladesh, basically, the power requirement to the tune of 60% is being met through ‘Gas’ based power plants. There is huge gap between demand and generation of power, which is being covered by coal, diesel, furnace oil and hydro (can be categorized as renewable energy). The contribution of this renewable energy is even less than 2% of total generation. As the demand for power is going up both wind and solar power can be considered as good options. A contract has been awarded to an Indian consortium to set up a 30MW wind power plant in Sonagazi, Dist. Feni. There is a plan to put up three windfarms of 50 MW each, to be installed at Chandpur, Cox’s Bazar and Khulan based on ‘wind mapping’. In the year 2016 there has been a detailed survey by a consultant from Netherland who declared potential of 16000 MW wind energy for Bangladesh. In the year 2018, USAID reported that Bangladesh is having wind power potential of 34,000 MW at a hub height of 100m based on the simulated study conducted by NREL (National Renewable Energy Laboratory). It is clear from the brief details furnished; there is huge potential of wind energy in Bangladesh.

The country’s first ever generation of electricity from wind is at Kutubia Island (20 KW, 50 turbines) with a capacity of 1 MW and another one at Muhuri Dam, Feni having a capacity of 0.9 MW (225 KW, 4Turbines) [14]-[15]. Vesta Company of Denmark is expected to invest 100 MW wind power plant which will be made in Patuakhali. This will be the largest wind power plant of Bangladesh [17]. According to our survey reports of the wind speeds all over the country, it can be assumed that the country has a minimum wind speed to produce wind energy. This is because the effective wind speed of wind turbines usually ranges between 3 and 25 m/s [18].

The aim of the article is to present results from the survey of wind speed and experiment conducted at Chittagong, Bangladesh during March 2018 to September 2018 using handmade small windmill. And the performances of small handmade windmill was measured by generation of power at specific range of heights for wind speed and the rotation of the rotor used in this purpose.

## 2. METHODOLOGY

### Wind Speed Data in Bangladesh

To use wind as an alternative energy source, we need reliable wind data throughout the year. For this reason, different papers are reviewed to summarize the wind speed related information. Table 1 is showing the wind speed in different locations all over the country at 20 m height. Table 2 is summarizes the wind velocity in the whole year (October 2009 to December 2010) at different height at Sandwip. Wind speed in north-eastern

part of Bangladesh is above 4.5 m/s while for the other parts of the country wind speed is around 3.5 m/s [19]-[20]. The strong south/south-western monsoon wind come from the Indian Ocean traveling a long distance over the Bay of Bengal, the rough coastal area of Bangladesh. This wind blows over Bangladesh from March to September with a monthly average speed 3 m/s to 9 m/s at different heights. According to studies from Meteorological Department, BCAS, LGED, and BUET [21], these wind speeds are available in Bangladesh mainly during the monsoon. (7 months, March to September). Rest of the months (October to February) wind speed remains either calm or too low. The peak wind speed occurs during the months of June and July [22]. The wind velocity at the coastal area and isolated island is quite higher than the rest of the locations. The Figure 1 is presenting the wind speed at the coastal areas of Bangladesh during March to September 2003 [23]. The wind velocity at the height of 20 m of Sandwip is not sufficient to generate electricity commercially. From the Table 2 the wind velocity at 45m and 60m is sufficient to generate electricity commercially. The average wind velocity at 60m and 45m height are 6.19m/s and 5.65 m/s (calculated) respectively, that are suitable for wind turbine as well as generator. But at winter, the wind velocity goes below the average wind velocity. To fulfil the electrical load demand at Sandwip, high-capacity wind turbine should be used.

*Power generation by turbine:* Power generated by a wind turbine at particular height, can be calculated by the following equation [24] and a schematic diagram windmill are shown in Figure 2.

$$P = \frac{1}{2} \cdot \rho \cdot a \cdot V^3 C_p \quad (1)$$

Where,  $\rho$ = wind power density ( $w/m^2$ ),  $a$ = swept area of blade ( $m^2$ ),  $v$  = velocity of wind ( $m/sec^2$ ),  $C_p$  = rotor efficiency. From that equation we can find out the theoretical wind power density at a certain height. We can also find the range of velocity of wind if we are aware of wind power density of that particular area and vice-versa.

$$C_p = \frac{\left(1 + \frac{\vartheta_d}{\vartheta_u}\right) \left(1 - \left(\frac{\vartheta_d}{\vartheta_u}\right)^2\right)}{2} \quad (2)$$

Let  $\lambda$  represent the ratio of wind speed  $\vartheta_d$  downstream to wind speed  $\vartheta_u$  upstream of the turbine, *i.e.*

$$\lambda = \frac{\vartheta_d}{\vartheta_u} \quad (3)$$

or

$$\lambda = \frac{\text{blade tip speed}}{\text{wind speed}} \quad (4)$$

$\lambda$  is called the tip speed ratio of the wind turbine. The blade tip speed in meters per second can be calculated

from the rotational speed of the turbine and the length of the blades used in the turbine, *i.e.*

$$\text{Blade tip speed} = \frac{\text{angular speed of turbine}(\omega) \times R}{\text{wind speed}} \quad (5)$$

where R is the radius of the turbine and  $\omega$  is measured in radian per second. Substitution of Equation 3 into Equation 2 leads to

$$C_p = \frac{(1 + \lambda)(1 - \lambda^2)}{2} \quad (6)$$

Differentiating  $C_p$  with respect to  $\lambda$  and equate to zero to find value of  $\lambda$  that makes  $C_p$  a maximum, *i.e.*

$$\frac{dC_p}{d\lambda} = \frac{(1+\lambda)(-2\lambda) + (1-\lambda^2) \cdot 1}{2} = 0 \text{ yielding } \lambda = -1 \text{ or } \lambda = \frac{1}{3}.$$

Now  $\lambda = \frac{1}{3}$  makes the value of  $C_p$  a maximum. This maximum value is  $\frac{16}{27}$ . Thus, the Betz limit says that no wind turbine can convert more than  $\frac{16}{27}$  (59.3%) of the kinetic energy of the wind into mechanical energy turning a rotor, *i.e.*  $C_{pmax} = 0.59$ . Wind turbines cannot operate at this maximum limit though. The real world is

well below the Betz limit with values of 0.35 – 0.45 common even in best designed wind turbines [24].

Wind velocity changes with height; the rate of increase of velocity with height depends upon the roughness of the terrain. The variation of average wind speed can be determined from the following power law expression [6]:

$$\frac{V_z}{V_{ref}} = \left( \frac{h}{h_{ref}} \right)^\alpha \quad (7)$$

Where,  $V_z$  and  $V_{ref}$  are the average speeds at height of h in meter and at the reference height of  $h_{ref} = 20$  above the ground respectively and  $\alpha$  varies from 0.1 to 0.4 depending on the nature of the terrain.

But those turbines are having cut-in velocity more than 4 m/s can generate sufficient energy. On the other hand, small turbine cannot generate sufficient energy.

Nowadays, research and development are going on to improve the technology and design medium or high-capacity turbine with low cut-in speed at 2.5 to 3.5 m/s for feasibility.

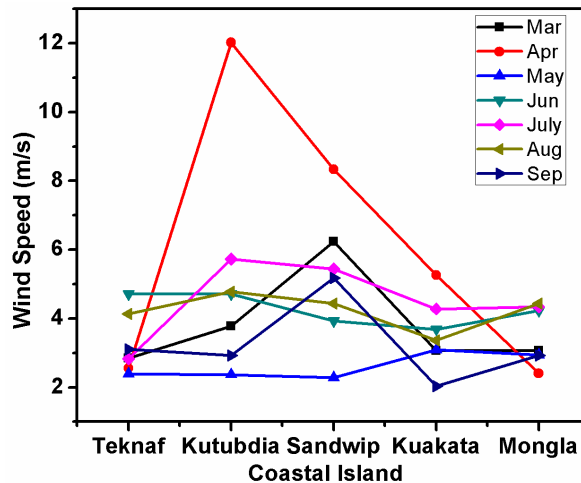

Fig. 1. Average wind speed at coastal Island in Bangladesh during March to September 2003 [23].

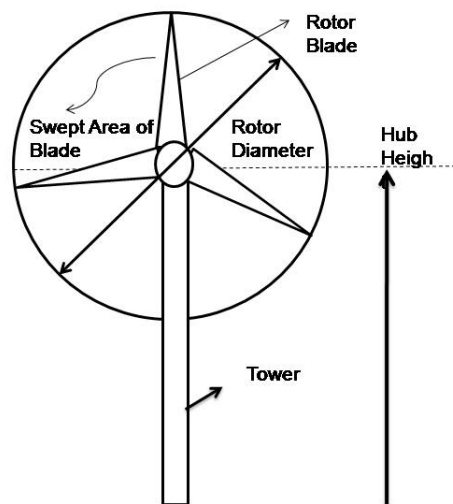

Fig. 2. Schematic diagram of wind mill for calculation.



**Table 1. Wind speed data at various locations at 20 m height [23] during October 2009 to September 2010.**

Locations	Months												Mean
	Jan	Feb	Mar	Apr	May	Jun	Jul	Aug	Sep	Oct	Nov	Dec	
Barisal	2.90	2.57	2.57	3.56	3.23	2.90	2.71	2.64	2.57	2.11	2.07	2.05	2.66
Bogura	1.95	2.20	3.05	4.03	4.15	3.66	3.42	3.05	2.56	2.20	1.83	1.71	2.82
Chittagong	3.64	2.88	4.95	5.01	5.51	6.89	7.09	6.83	4.64	2.82	3.39	2.20	4.65
Comilla	2.26	2.70	2.57	5.45	3.83	3.20	2.88	2.95	1.82	2.38	1.63	1.70	2.78
Cox's Bazar	3.76	3.83	4.51	5.58	3.83	4.14	3.83	3.95	3.20	3.26	2.57	3.26	3.81
Dhaka	3.39	3.26	4.39	5.77	6.33	5.71	6.01	5.89	4.39	3.45	2.64	2.95	4.52
Dinajpur	2.68	2.44	4.88	2.44	2.93	2.68	2.56	2.44	2.44	3.54	2.44	2.44	2.83
Hatiya	3.04	2.64	4.16	3.97	4.82	6.47	5.75	2.64	2.96	2.77	3.06	2.57	3.74
Jessore	2.88	2.95	4.95	8.34	8.34	6.27	6.15	4.95	4.33	3.45	3.32	3.20	4.93
Khepupara	4.20	4.39	3.83	7.09	5.83	4.71	4.14	3.95	3.57	3.70	2.95	2.57	3.74
Khnulna	2.96	1.65	3.04	3.05	4.16	3.89	3.31	2.44	2.51	1.98	3.31	2.38	2.89
Kutubdia	1.77	1.82	2.32	2.70	2.77	3.65	3.61	3.14	2.11	1.45	1.19	1.29	2.32
Mongla	1.07	1.25	1.72	2.51	2.92	2.63	2.48	2.35	1.83	1.27	1.02	1.01	2.20
Rangamati	1.45	1.65	4.42	3.10	2.11	3.32	1.72	2.24	1.45	1.45	1.39	1.59	2.15
Sandip	2.32	3.01	3.20	4.83	2.44	3.83	3.39	2.70	2.32	1.63	1.70	1.70	2.76
Sylhet	2.20	2.93	3.29	3.17	2.44	2.68	2.44	2.07	1.71	1.95	1.89	1.83	2.38
Teknaf	3.70	4.01	4.39	4.01	3.32	3.89	3.83	2.88	2.44	2.20	1.57	1.76	3.17
Patenga	6.22	6.34	7.37	7.92	8.47	8.69	9.20	8.54	7.43	6.93	6.71	5.91	7.48
Sathkhira	4.21	4.40	3.84	7.10	6.11	4.76	4.27	4.03	3.62	3.78	3.54	2.81	4.37
Thakurgaon	4.15	5.06	7.93	8.43	8.66	8.05	7.93	6.59	6.34	5.98	5.25	4.76	6.59

**Table 2. Wind velocities at various height at Sandwip during October 2009 to September 2010 [23].**

Month ↓	45 m height			60 m height			80 m height		
Terrain →	0.2	0.3	0.4	0.2	0.3	0.4	0.2	0.3	0.4
Jan	4.09	4.45	4.83	4.34	4.86	5.42	4.60	5.32	6.26
Feb	3.11	3.49	3.79	3.41	3.82	4.26	3.63	4.18	4.78
Mar	7.28	7.91	8.59	7.72	8.66	9.65	8.22	9.46	10.84
Apr	9.75	10.59	11.50	10.34	11.59	12.93	11.01	12.67	14.51
May	2.66	2.89	3.14	2.82	3.16	3.53	3.01	3.46	3.96
Jun	4.59	4.99	5.42	4.87	5.46	6.09	5.18	5.97	6.83
July	6.38	6.90	7.50	6.74	7.56	8.43	7.18	8.27	9.46
Aug	5.19	5.63	6.12	5.50	6.17	6.88	5.86	6.75	7.72
Sep	6.06	6.50	7.14	6.42	7.20	8.03	6.84	7.87	9.01
Oct	4.84	5.25	5.71	5.13	5.75	6.41	5.46	6.29	7.20
Nov	4.41	4.78	5.20	4.67	5.24	5.84	4.97	5.73	6.55
Dec	4.13	4.48	4.87	4.37	4.90	5.47	4.60	5.36	6.15
Avg	5.25	5.65	6.14	5.52	6.19	6.91	5.88	6.77	7.77

**Working Principle and Preparation of Small Windmill**

Wind is actually another form of solar energy. The uneven heating of the atmosphere causes temperature gradient at the surface of the earth, which results in the wind flow. The rotation of earth and irregularities of the earth have vital impacts on wind velocity. A wind turbine converts the kinetic energy of the wind to

generate electric or mechanical energy. Wind passes over the blades exerting a turning force.

The rotating blades turn a shaft inside the nacelle, which goes into a gearbox. The gearbox increases the rotation speed for the generator, which uses a magnetic field to convert the rotational energy into electrical energy. The power output goes to a transformer, which converts the electricity from the generator to the right

voltage for the distribution system [25]. In a simplistic view, the working principle of a wind turbine is just opposite to that of a fan as shown in Figure 3.

**Wind turbine:** Converts wind energy into rotational (mechanical) energy. a) Gear system and coupling: It steps up the speed and transmits it to the generator rotor. b) Generator: Converts rotational energy into electrical energy. c) Controller: Senses wind direction, wind speed, generator output, and temperature and initiate appropriate control signals to take a control action.

**Preparation of small wind mill:** Rotor is made of plastic with three rotor blades. A 6V D.C. generator is used to convert mechanical energy to electric energy. The based was made by wood frame with PVC pipe for shape and size. The LED light (9 LEDs) was used instead of incandescent light bulbs. Since LED is more efficient and energy saving.

**Calculation of the turbine:** We used the following data to calculate the power output of the turbine:

Radius of the rotor,  $r = 0.05$  m.

Average rotor efficiency,  $C_p = 0.35$

wind power density in Chittagong using,  $= 60.33$  w/m<sup>2</sup>

So, power generation in Chittagong according,

$$P = 8.34 \text{ W}$$

But rotor radius of the small wind turbines is between (1-1.5) m range. So, we have calculated wind power in this experiment with rotor size 0.05m (Handmade small windmill in experiment) and 1.5 m (ideal micro wind turbine/small windmill).

The Figure 4 is showing the Kutubdia wind power area and inset handmade small windmill and the Figure 5 are showing the schematic diagram of wind power generation process at Kutubdia. From the concept of kutubdia turbine, a small handmade windmill was made to examine its performances. The small handmade windmill was used to setup experiment with limited range of rotation of the rotor. With this limitation in rotation system, therefore, it is not possible to go through above 60 m height. So, we started from 20m height and we are able to measure 45 m height. It is a trial experiment and that hopes to present a full analysis in future with all suitable parameters.

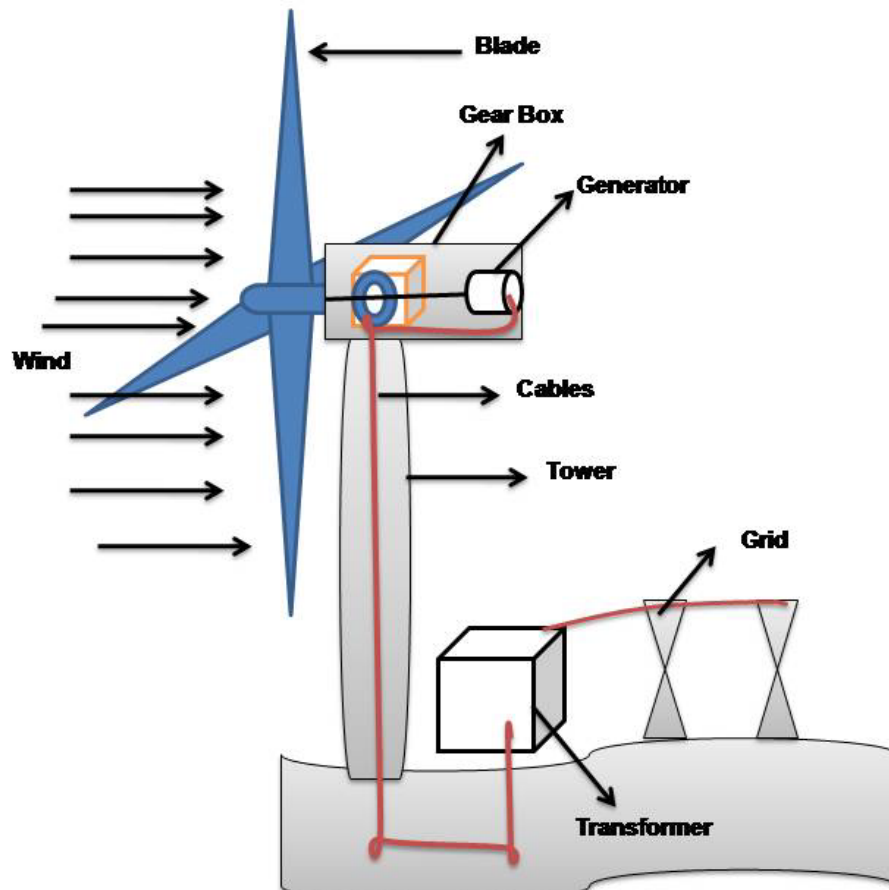

Fig. 3. Overview of working principle for wind turbine.





Fig. 4. Kutubdia wind power station (inset handmade wind mill).

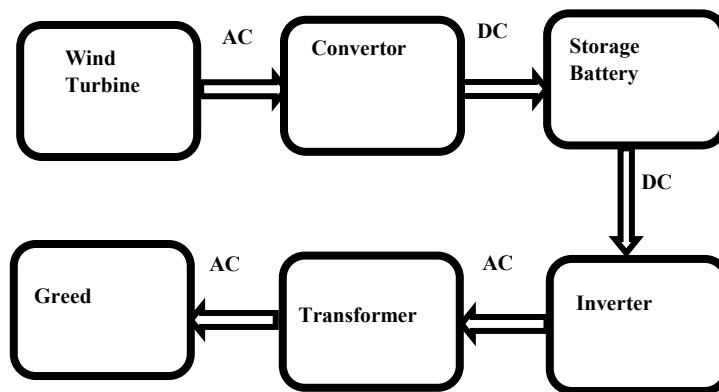

Fig. 5. Schematic diagram of wind electricity at Kutubdia.

### 3. RESULTS AND DISCUSSION

The handmade small windmill at Chittagong was used from March to September 2018. The experimental results were collected without measuring the wind speed and just measured the rotation of the rotor and calculated voltages, currents and power generation parameters as shown in Figures 6, 7, and 8, respectively. It is well known that the effective wind speed of wind turbines usually ranges between 3 and 25 m/s [14]. Moreover, the amount of wind energy that can be produced using our small windmill with normal wind speed, which is usually we get in our everyday life, was observed.

Our handmade small wind mill was run within the range of rotation 474 to 2739 rpm. The height for small windmill used was in the range of 20-45 m and the results and analysis of the data are presented in Figures 6, 7, 8 and Table 3, respectively.

By using the handmade small windmill, we measured voltage generation with respect to rotation. Figure 6 is presenting rotation versus voltage in operation of small windmill. From the figure it is easy to say that the rotation is directly proportional to the generation of voltage. That means, increasing the

rotation will increase the voltage generation. So that, if the wind speed increases, the rotation of small windmill will increase and can get more voltages.

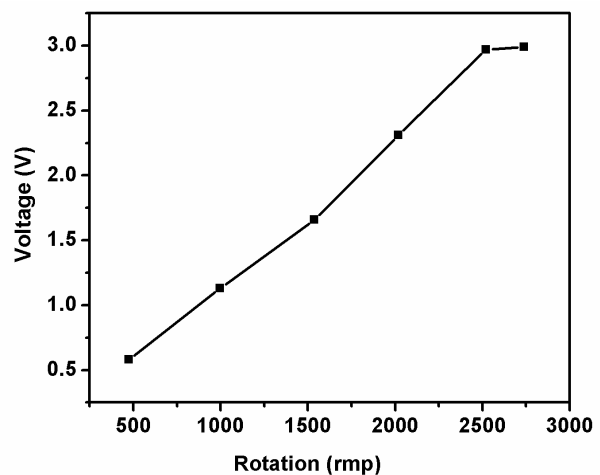

Fig. 6. Rotation versus voltage generation in operation of micro-wind mill.

Figure 7 is showing the current produced by the small wind mill with the rotation range 474 to 2739 rpm. The figure is indicating that increasing the rotation will increase the production of current by the wind mill. The small windmill rotor has limitation in rotation; therefore, it is not able to go furthermore in rotation.

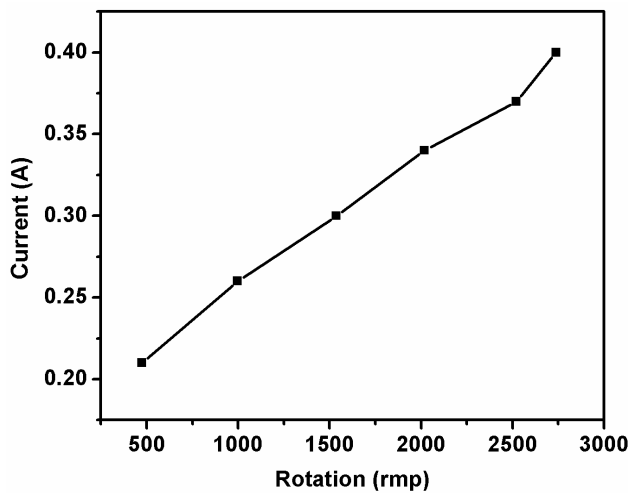

Fig. 7. Rotation versus current generation in operation of micro-wind mill.

Figure 8 is showing the production of power generated by a small wind turbine/wind mill. Here, the power is also directly proportional to the rotation of the rotor. The rotor has a limitation in rotation for power generation from small windmill. Therefore, it generated as small amount of power. If the rotation increases the power generation will increase. The Table 3 summarizes the data shown is the above figures.

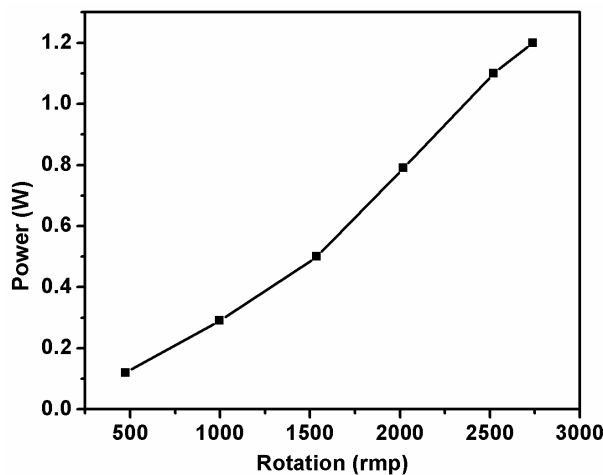

Fig. 8. Rotation versus power generation in operation of micro-wind mill.

Therefore, from the above wind speed survey data (Figure 1, Tables 1 and 2), and small windmill experimental results (showing in Figure 6, 7, 8 and Table 3, respectively), it may be concluded that at 20 m height or above is more suitable for wind energy and

and the coastal areas of the country has sufficient wind speed for wind electricity generation [26].

Table 3. Rotation, voltage, current and power data of the small wind turbine operated in this study during March to September 2018.

Rotation (rpm)	Voltage (V)	Current (A)	Power (W)
474	0.58	0.21	0.12
998	1.13	0.26	0.29
1538	1.66	0.30	0.5
2020	2.31	0.34	0.79
2521	2.97	0.37	1.1
2739	2.99	0.40	1.2

#### 4. CONCLUSIONS

The survey reports for wind speed and a handmade small windmill experimental results indicate that coastal zone in Bangladesh is a better wind potential area for wind energy. March-September is the most suitable time to generate more wind energy. Using wind energy, Bangladesh can save natural gas. Cost comparison shows producing electricity by wind is much cheaper than other conventional sources. The experiment with handmade small windmill is feasible, not only in coastal areas but all over Bangladesh. So, the wind energy can be a great alternative energy resource in Bangladesh. The country needs more survey, research, and technical support to improve this sector. Bangladesh is falling far behind in the scientific use of this renewable wind energy due to the lack of technology and research in this field.

#### ACKNOWLEDGEMENT

Department of Applied Chemistry and Chemical Engineering, University of Rajshahi, Bangladesh. Comments and suggestions from anonymous referees are highly appreciated for extremely helpful suggestions and comments.

#### REFERENCES

- [1] Kutubi N., 2009. Welcome to Kutubdia - an Island in the Bay of Bengal: Hybrid Power Plant at Kutubdia (Report No. Spot 5). From the world wide web : <http://kutubdia.blogspot.com/2009/10/hybrid-power-plant-at-kutubdia.html>.
- [2] Bhattacharyya S.C., 2015. Mini-grid based electrification in Bangladesh: Technical configuration and business analysis. *Renewable Energy* 75: 745-761.
- [3] Rasel M.A.J., Siraj S., and Rahman K.M., 2012. Prospect of renewable energy as the solution of the existing crisis of Bangladesh. *International Journal of Scientific and Engineering Research* 3:1-7.

- [4] Baten M.Z., Amin E.M., Sharin A., Islam R., and Chowdhury S.A., 2009. Renewable energy scenario of Bangladesh physical perspective. Proceedings of the *IEEE 1st International Conference on the Developments in Renewable Energy Technology (ICDRET)*. ISBN: 978-1-4244-6012-0, December 19. Dhaka, Bangladesh
- [5] Khatun F., 2013. CPD-CMI Research Colloquium, FDI in the Energy and Power Sector in Bangladesh: Revisiting Policies and Contribution. March 11, Dhaka, Bangladesh.
- [6] Hossain M.A., Hossain M.Z., Rahman M.A., 2014. Perspective and challenge of tidal power in Bangladesh. *International Journal of Power Engineering* 8(7) :1147-1150.
- [7] Shaik M.A., Chowdhury K.M.A., Sen S., and Islam M.M., 2017. Potentiality of wind power generation along the Bangladesh Coast. In *Proceeding of the 1st International Conference on Mechanical Engineering and Applied Science (ICMEAS)*, February 22-23, 2017, Dhaka, Bangladesh. *AIP Conference Proceeding* 1919(1): 020035-1 – 020035-10. <https://doi.org/10.1063/1.5018553>.
- [8] Mukut M.I., Islam Md.Q., Alam M.M., 2007. The wind energy scenario in coastal region of Bangladesh. *Proceedings of the International Conference on Mechanical Engineering (ICME2007)*, December 20-31. Dhaka, Bangladesh.
- [9] Alam M.M. and J.D. Burton, 1998. The coupling of wind turbine to centrifugal pumps. *Journal of Wind Engineering* 22: 223-234.
- [10] Suresh R. and D.S. Block, 1998. Field testing of geared type deep well wind pumps in India. *Journal of Wind Engineering* 22: 17-129.
- [11] Amin M.T., 2015. Prospects of wind energy in Bangladesh. *International Journal of Advanced Renewable Energy Research* 2(8): 213-218.
- [12] Sustainable and Renewable Energy Development Authority (SREDA): National Database on Renewable Energy /Wind Projects. January 06, 2021 from the world wide web: <https://ndre.sreda.gov.bd/index.php?id=1&i=11>.
- [13] Ullah M.H., Hoque T., and Hasib M.M., 2012. Current status of renewable energy sector in Bangladesh and a proposed grid connected hybrid renewable energy system. *International Journal of Advanced Renewable Energy Research* 1: 618-627.
- [14] Farha N., Nur-Ul-Safa M., Rahamatullah B.D., Ali M.S., 2012. Prospects of wind energy in the coastal region of Bangladesh. *International Journal of Scientific and Engineering Research* 3(8):1-5.
- [15] Wyatt A. 1986. *Electric Power: Challenges and Choices*. Canada: Book Press, Toronto, p-63.
- [16] Saifullah A.Z.A., Karim M.A., Karim M.R. 2016. Wind Energy Potential in Bangladesh. *American Journal of Engineering Research (AJER)* 5(7): 85-94.
- [17] Li G. and J. Zhi 2016. Chapter 2: Analysis of Wind Power Characteristics. In Ed. Wang N., Kang C. and Ren D. In *Large Scale Wind Power Grid Integration*. Academic Press Elsevier Inc., p-28. <https://doi.org/2013-0-18686-2>.
- [18] Li G., and Zhi J. 2016. Chapter 2: Analysis of Wind Power Characteristics. In Ed. Wang N., Kang C. and Ren D. In *Large Scale Wind Power Grid Integration*. Academic Press Elsevier Inc., p-19-51. <https://doi.org/2013-0-18686-2>.
- [19] Khan M.J., Iqbal M.T., Mahboob S., 2005. A wind map of Bangladesh. *Renewable Energy* 29(5):643-660.
- [20] Ramachandra T.V. and B.V. Shruti, 2005. Wind energy potential mappings in Karnataka, India, using GIS. *Energy Conversion and Management* 46: 1561-1578.
- [21] Mukut A.N.M.M.I, Islam M.Q., and Alam M.M. 2008. Analysis of wind characteristics in coastal areas of Bangladesh. *Journal of Mechanical Engineering* 39(1): 45-49.
- [22] Ahmmed S., Islam M. Q., 2004. Wind Power for Rural Areas of Bangladesh. *3rd International Conference on Electrical and Computer Engineering (ICECE)*, December 28-30, Dhaka, Bangladesh.
- [23] Mirza R., Hossain M., and Hossain A., 2010. Design of an often cost affective wind power system for a remote Bangladesh locality. *Thesis*. BRAC University, Bangladesh. Retrieved from the World Wide Web: <http://dSPACE.bracu.ac.bd/xmlui/handle/10361/847>.
- [24] Manyonge A.W., Ochieng R.M., Onyango F.N., and Shichikha J.M., 2012. Mathematical modelling of wind turbine in a wind energy conversion system: Power coefficient analysis. *Applied Mathematics Sciences* 6(91): 4527-4536.
- [25] Miah M., 2015. Denmark will invest in wind power plant. Energy Bangla. Retrieved from the World Wide Web: <http://energybangla.com/denmark-will-invest-in-wind-power-plant/>.
- [26] Khadem S.K. and M. Hussain, 2006. A pre-feasibility study of wind resources in Kutubdia Island, Bangladesh. *Renewable Energy* 31: 2329–2341.



[www.ericjournal.ait.ac.th](http://www.ericjournal.ait.ac.th)

## Feasibility of Geoscience to Determine the Location of Micro-hydro Power Potential for Rural Areas

Stevanus Nalendra Jati\*, Samuel R.O. Manik<sup>†</sup>,  
Dewi Puspita Sari<sup>#</sup>, and Dendya Adanta<sup>†, 1</sup>

**Abstract** – The micro-hydro power plant (MHPP) is a viable solution to the electricity crisis in rural areas. However, the lack of application is due to the constraints of the location review, which is expensive and time-consuming. To increase the efficiency of its application, it is necessary to ascertain the methods of reducing the costs and times. The feasibility of an analytical hierarchy process (AHP) based on the geographical information systems (GIS) to determine the ideal location of micro-hydro power was proposed. Based on the geoscience approach, surface mapping (lithology) and GIS (morphology, morphometric, and topography) visualize case study areas accurately and precisely to accurately determine the ideal areas. The ideal area is one containing a good potential head and hard rock plain (granodiorite). The ideal area is to be determined through field observations. According to these observations, the potential head was 4 m, the discharge was 0.83 m<sup>3</sup>/s, and the field contained a plain type of granodiorite. The estimated hydropower of 32.15 kW (micro-scale), has the potential to supply electricity to 35 households with 50% efficiency and power of 0.45 kW/house. In consideration of energy losses and investment costs, the propeller turbines were proposed for this case. Thus, the AHP method based on GIS to determine the ideal locations of micro-hydro power in rural areas can be utilized.

**Keywords** – geographical information system, lithology, micro-hydro, morphometry, rural areas topography.

### 1. INTRODUCTION

In 2019, according to reports by the World Bank, there are presently many people in South and Southeast Asia without access to electricity. The electrification ratio (ER) in these locations is 91.6% and 98%, respectively. Reportedly, the four countries with the lowest ER in South Asia: Bangladesh having 95.2%; Nepal of 93.9%, India of 95.2%, and Bhutan of 100% [1]. Meanwhile, in Southeast Asia: Myanmar has the lowest ER of 66%, Cambodia of 91.6%, the Philippines of 94.9%, and Indonesia of 98.5% [1]. Factually, electrification is an effective method for improving prosperity, and it is performed through three methods in rural areas: off-grid, on-grid, and mini-grid. The off-grid process is more desirable because its civil, electrical, and mechanical construction is more manageable (cheaper) than on-grid and mini-grid.

The off-grid systems utilize micro-hydro as an independent power plant, often used in rural areas than a wind turbine and solar photovoltaic [2]. Since per-kW the life cycle cost of micro hydro is more profitable than wind and solar photovoltaic [2]. This is the rationalization of some developing countries using micro-hydro as independent power plants for their rural areas [3]-[7]. Therefore, micro-hydro is a possible solution for covering areas facing an electricity crisis in South and Southeast Asia. Hence the potential to exploit and manufacture energy from water in these countries is large: Bangladesh generates 330 MW [8], Nepal of 83,300 MW [8], India 148,700 MW [8], Myanmar of 39,624 MW [9], Cambodia of 10,000 MW [1], Philippines of 15,393 MW [10], and Indonesia of 81,100 MW [11]. However, in South and Southeast Asia, the energy generated from water exploitation (installed capacity) is presently low [1]: Bangladesh generates of 69.7% (230 MW), Nepal of 1.3% (1059 MW), India of 33.67% (50,066 MW), Myanmar of 8.2% (3255 MW), Cambodia of 13.8% (1380 MW), Philippines of 24.1% (3708 MW), and Indonesia of 6.84% (5548 MW).

The micro-hydro power plant (MHPP) is an independent power plant that harnesses energy from local water depending on its flow and slope structure [12]. Furthermore, previous studies focused on examining the mechanical and electrical feasibility of MHPP. On the mechanical side, Williamson and Simpson [13] proposed selecting turbine technology by qualitative and quantitative analysis, where they concluded that Turgo turbines are more applicable in rural areas. Additionally, they also recommended a method for calculating the diameter of a penstock, and suggested the head loss limit for the penstock system to be set at 10%. Adanta, et al. [2] discussed the effect of

\*Study Program of Geological Engineering, Faculty of Engineering, Universitas Sriwijaya, Indralaya 30662, South Sumatera, Indonesia.

<sup>†</sup>Geosriwijaya Nusantara Limited liability company, Palembang 30157, South Sumatera, Indonesia.

<sup>#</sup>Study Program of Mechanical Engineering Education, Faculty of Teacher Training and Education, Universitas Sriwijaya, Indralaya 30662, South Sumatera, Indonesia.

<sup>†</sup>Department of Mechanical Engineering, Faculty of Engineering, Universitas Sriwijaya, Indralaya 30662, South Sumatera, Indonesia.

<sup>1</sup>Corresponding author;

Tel: +62 711 580 272, Fax: + 62 711 580 272.

E-mail: [dendiyadanta@ymail.com](mailto:dendiyadanta@ymail.com) or [dendiyadanta@unsri.ac.id](mailto:dendiyadanta@unsri.ac.id)



turbulence modeling on the performance of MHPP using the computational method, where they identified that the turbulence model influenced the prediction error. On the electrical side, Haidar, *et al.* [14] suggested the generator type for MHPP to be direct current (DC) for the off-grid system while the mini-grid can use either alternating current (AC) or DC. Febriansyah, *et al.* [15] tested the feasibility of a storage system applicable in rural areas and concluded that an off-grid system with a DC was the proper solution.

Although studies have been carried out comprehensively, the lack of application of MHPP is believed to be due to the constraints of location review, which is expensive and time-consuming. The analytical hierarchy process (AHP) based on geographic information system (GIS) overlay was proposed because it helps determine a standard construction layout for the micro-hydro. It is also used to ascertain plains' strength, riverbed morphometry, and topography around the river.

Thus, this study aims to examine the feasibility of GIS-based on the AHP method in determining the ideal MHPP location.

## 2. DESCRIPTION OF STUDY AREA

To ascertain the reliability of the AHP method, the Kikim river in Lubuk Tuba villages, Lahat-South Sumatra, Indonesia, was used as a case study. The Kikim river was chosen because its flow passes through a village with an electricity crisis in Lubuk Tuba village, Pseksu district, Lahat-South Sumatra, Indonesia [16]. Although there is a national electricity grid supply in Lubuk Tuba villages, the distributed capacity is low and is only six hours daily [16]. It is expected that the results of this study can provide a suggestion to the Lahat district government in overcoming the energy crisis in its areas. Furthermore, this method can be applied to areas with similar conditions (rural areas with rivers).

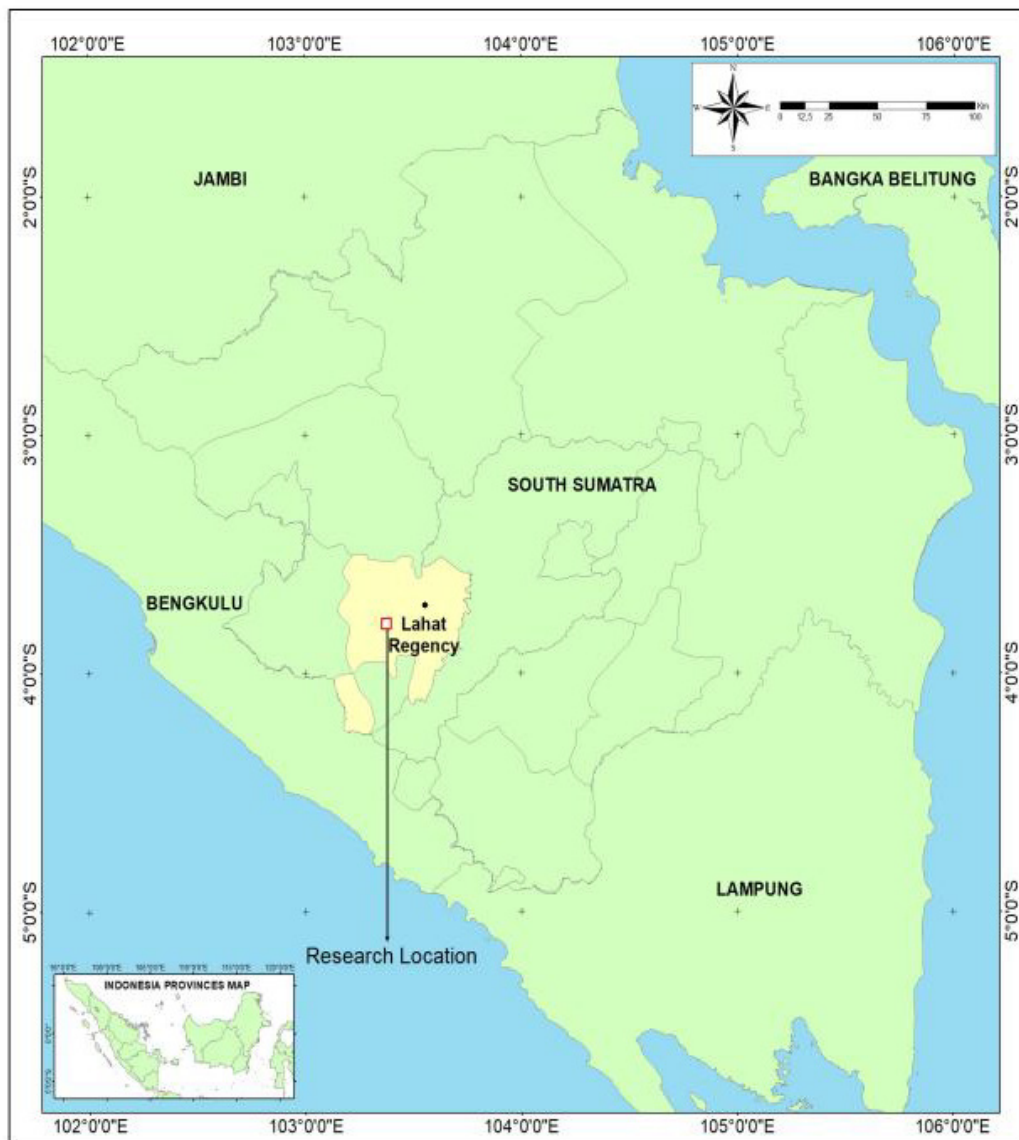

Fig. 1. Location of the study area.



The Lubuk Tuba village is located in the southwestern Palembang city (Figure 1), the specific coordinates are 9578000-9583000 S and 317000-322000 E UTM WGS-84 with areas of 20.05 km<sup>2</sup> (Figure 2).

**2.1 Geology**

Field observations were carried out to obtain a visualization of the surface geological conditions. The surface geology is necessary for lithological analysis (Appendix 1). Thus, the stratigraphy of the area is characteristic of Granodiorite (Late Cretaceous),

Talangakar Formation (Late Oligocene-Early Miocene), Gumai Formation (Early-Middle Miocene), and Airbenakat Formation (Middle Miocene). Granodiorite is brittle and competent, while the other formations tend to be ductile (plastic). This is relevant when constrained by topography, as the southern part of the study area has a high topography that is quite resistant to weathering. Meanwhile, the distribution of rocks in the central and northern parts of the study area consists of incompetent rocks.

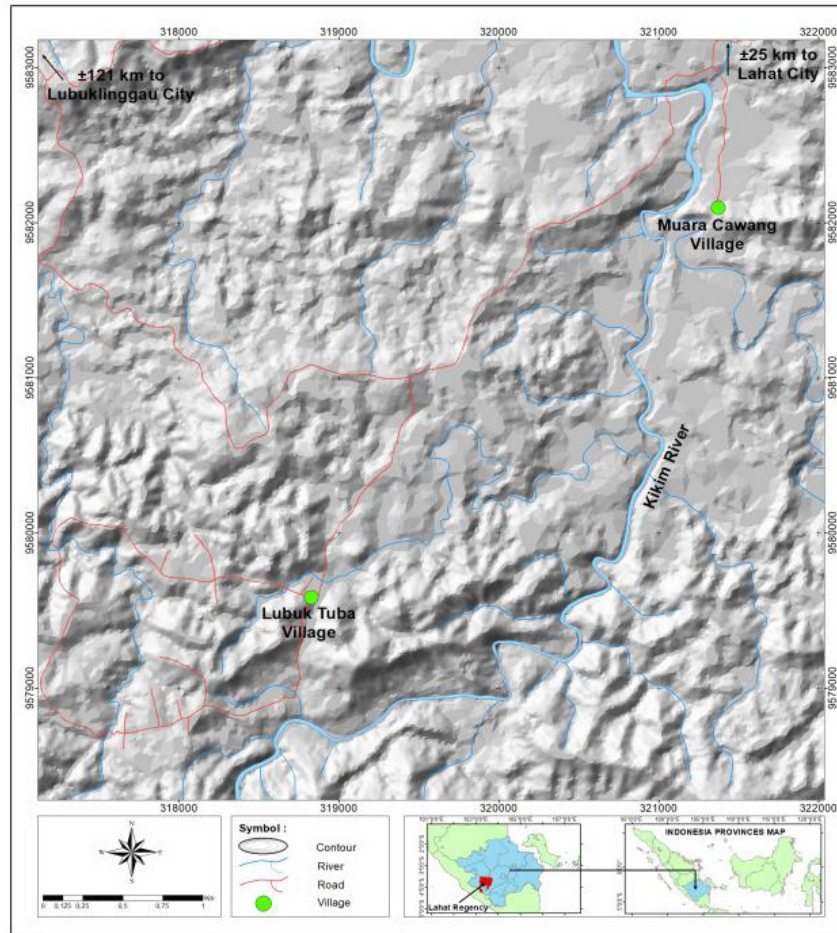

**Fig. 2. Topography view of the study area.**

**2.2 Morphometry**

Slope classifiers are defined in Table 1 [17]. River slope levels were mainly flat, with a few ramps present. This condition was verified by discovering sedimentary rocks with low resistance, such as claystone, siltstone, and others in the region studied (Appendix 1). Whereas in the southern region, the slope is steep and dominated by the rocks having high resistance namely granodiorite (red color in Appendix 1).

Based on the classification in Figure 2 based on Table 1 regarding the southern region of the case study, the river slope domination is moderately steep (Appendix 2). Whereas in the eastern regions, it is mainly gentle sloping and nearly flat (Appendix 2).

**Table 1. River slope classification [17].**

Score	Elevation (m)	Land category	Slope, (%)	Classification
1	< 50	Lowlands	0-2	Flat or almost flat
2	50-200	Low hills	3-7	Gently sloping
3	200-500	Hills	8-13	Sloping
4	500-1000	High hills	14-20	Moderately steep
5	> 1000	Mountains	21-55	Steep

### 3. METHOD

Three stages are involved in determining the location and technology of MHPP: acquisition (data collection by GIS), processing (analysis of morphometry parameters using AHP), and post-processing (identification of suitable technology turbine based on the condition obtained).

#### 3.1 Acquisition Data by GIS

This study employed three practical data acquisitions: river map using [tanahair.indonesia.go.id/portal-web](http://tanahair.indonesia.go.id/portal-web), rainfall using [dataonline.bmkg.go.id](http://dataonline.bmkg.go.id), and Seamless Digital Elevation Model (DEM) using [tides.big.go.id](http://tides.big.go.id). Delineation of major alignments was interpreted using DEM [18]-[20]. The DEM analysis utilized the available shuttle radar topography mission (SRTM) 57.13 from the United States Geological Survey (USGS) web, which provided three different resolutions, *i.e.*, 1 arc-second (30 m), 3 arc-second (90 m), and 30 arc-second (1.0 km). This study applied a 30 m resolution with a set of data measured in 2014. The Geographic Information System (GIS) implementation is increasingly being used for hazard assessment [21], due to its ability to combine several parameters to obtain micro-hydro layout map.

#### 3.2 Assessment of AHP Methods

The ideal construction foundation is compact lithology due to its construction advantages, with minimal risk of landslides. The foundation was grouped into three: granodiorite, claystone, and siltstone. The highest score was the granodiorite stone, while the medium was claystone, and the lowest was siltstone [22]. The granodiorite stone is considered compact and robust as a foundation, and the influence of the geological structure is insignificant [22]. The power plant's location far from the river is not ideal due to its bulky system, which incurs a large investment cost. Therefore, the scores of the assessment based on the distance between the river and power plants were grouped into three: 3 below 100 m (< 100 m); 2 between 100 and 200 m (100 to 200 m), and 1 which reached 200 m (> 200 m). The river slope is needed as an assessment parameter, as whenever the river is dammed, flooding does not occur in the area. Therefore, the river slope scoring levels are grouped into three: 3 between 21% and 100%, 2 between 8% and 20%, and 1 between 1% and 7%. Table 2 is a summary of the leveling of lithology within the foundation (l), the distance of the river to a potential power plant location (d), and river slope (s).

**Table 2. Description of leveling of l, d, and s.**

Score	l	d	s
3	Granodiorite	< 100 m	21 – 100%
2	Claystone	100 – 200 m	8 – 20%
1	Carbonate siltstone	> 200 m	1 – 7%

#### AHP procedure calculation for determine of micro-hydro potential layout

The AHP method developed by Saaty (2018) [23] is a complex decision-making method that has been simplified, where it adopted the 32 factorial design analysis. This analysis can also be referred to as an optimization method. It implies  $32 = 9$ , which suggests a conclusion with a maximum value of 9. Furthermore, in determining the location, three parameters were used: lithology as the foundation (l), the distance between the river and a potential power plant location (d), and river slope (s). As these three parameters are part of the geoscience aspect, they are given a value based on their influence on location determination [23]. Table 2 shows how each parameter is assessed.

The parameters of l, d, and s are calculated using a factorial design. These parameters are made into a 1 x 3 matrix or  $\begin{bmatrix} l & d & s \end{bmatrix}$  called A, while B matrix is

$$\begin{bmatrix} 1/l & 1/d & 1/s \\ 1/l & 1/d & 1/s \\ 1/l & 1/d & 1/s \end{bmatrix}$$

The interaction between factor A and B is found in Equation 1:

$$A \times B = Y \quad (1)$$

Afterward, the treatment combination of A and B was done by Equation 2:

$$(D \times E) \times X = F \quad (2)$$

where D is  $\begin{bmatrix} l \\ d \\ s \end{bmatrix}$  E is  $\begin{bmatrix} 1/l & 1/d & 1/s \end{bmatrix}$ , and X is

$$\begin{bmatrix} 1/Y_1 \\ 1/Y_2 \\ 1/Y_3 \end{bmatrix}$$

The next, each F is average by times with 1/n:

$$1/n \times F = T \quad (3)$$

where n is the number of parameters of 3, the determination index value (K) and consistency index (C).

$$(D \times E) \times T = K \quad (4)$$

$$S \times K = C \quad (5)$$

where S is  $\begin{bmatrix} 1/T_1 & 1/T_2 & 1/T_3 \end{bmatrix}$ . For information, the  $C_i \leq 9$ .

The  $C_i$  is used to determine the location for MHPP, where its value is defined in Table 3 [23]. The  $C_i$

indicates the potential of the Kikim river. The greater the  $C_i$  the more the potential.

**Table 3. Definition of  $C_i$  from 1 to 9 [23].**

Value	Explanation
1	Equal potential
2	Weak or slight
3	Moderate potential
4	Moderate plus
5	Strong potential
6	Strong plus
7	Very strong potential
8	Very, very strong potential
9	Extreme potential

Furthermore,  $C_i$  will be placed on the map obtained through geographic information systems (GIS) to generate an ideal area. These areas will then be represented through maps.

Appendix 3, 4, and 5 are the data used in AHP analysis. Appendix 3 and 4 involve the lithology aspect and the distance of the river from a potential power plant location, respectively. Thus, Appendix 3 and 4 are generated by the scores of Appendix 1 using Table 2. Whereas, Appendix 5 which is the river slope, is dependent on Appendix 2 using Table 2.

### 3.3 Morphometry Analysis Method

Rivers with large water discharge cannot be said to be in an area with micro-hydro potential. Morphological aspects such as hillside, riverbed slope, and river shape influence the determination of location for the layout of the MHPP construction [24]. Furthermore, the lifetime of MHPP is influenced by terrain foundation. A good foundation criterion is a compact rock able to withstand heavy loads and equally resistant to geological influence [22]. Therefore, several morphological conditions should be considered in determining the location of MHPP: A lowland must be absent in the riverside (flood potential), to reduce the investment cost of dams; The slope of the channel to the forebay has to be nearly flat. Good lithology makes it easy to build a forebay, which is placed close to the powerhouse with a large elevation

(head). This criterion matches the morphometry of the river having a steep slope. Penstock pipes placed on the steep river slope with a good lithology condition enhance the strength of the construction foundation. The distance between the powerhouse and the residential area has to be a maximum of 3 km.

Data collection for morphometric analysis was done directly to determine the layout of the dam, the position of the penstock pipe, and the powerhouse. Three aspects of morphometry were considered: river slope to ascertain the position of power plant construction, river shape in preparation for dam construction, and riverbed slope for penstock pipe installment (water elevation).

### 3.4 Determination of Micro-hydro Potential and Its Technology

After determining the layout for the MHPP construction, the next is to estimate the available hydropower. The hydropower potential is a function of discharge (Q) and head (h) (Equation 6).

$$P=Q \times h \times g \times \rho \tag{6}$$

where g is gravity and  $\rho$  is water density.

The discharge (Q) is a function of the cross-sectional area (a) and the stream of water velocity (v). To ascertain the discharge: first, measure the width and height of the river using a scale; second, measure the velocity of water through a current meter. The measurement of the width and height of the river is necessary to determine cross-sectional areas. The river's average velocity is obtained by measurement at twelve locations spread over six sites at the top, three at the middle, and three near the riverbed. The measurement was made in May 2018 (the transition from the rainy season to dry). The schematics of the location measurement of water velocity is seen in Figure 3. Since Indonesia has two seasons (rain and dry), the discharge (Q) measurement results should be compared with the rainfall graph of local areas. This is to determine the discharge (Q) that is exploitable, and anticipate the failure of a turbine due to less power input or discharge.

The determination of turbine technology uses the head and discharge relationship graph shown in Figure 4 [13].

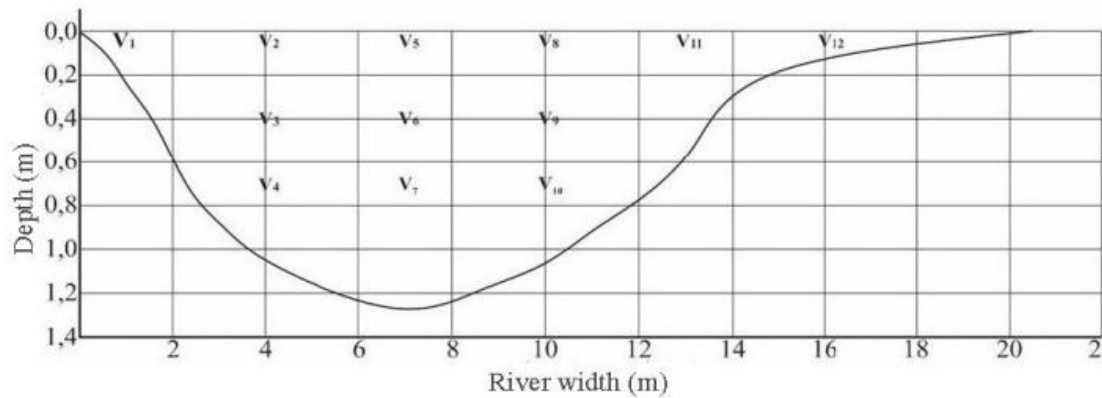

Fig. 3. Schematic section of riverbed and water velocity measurement locations.

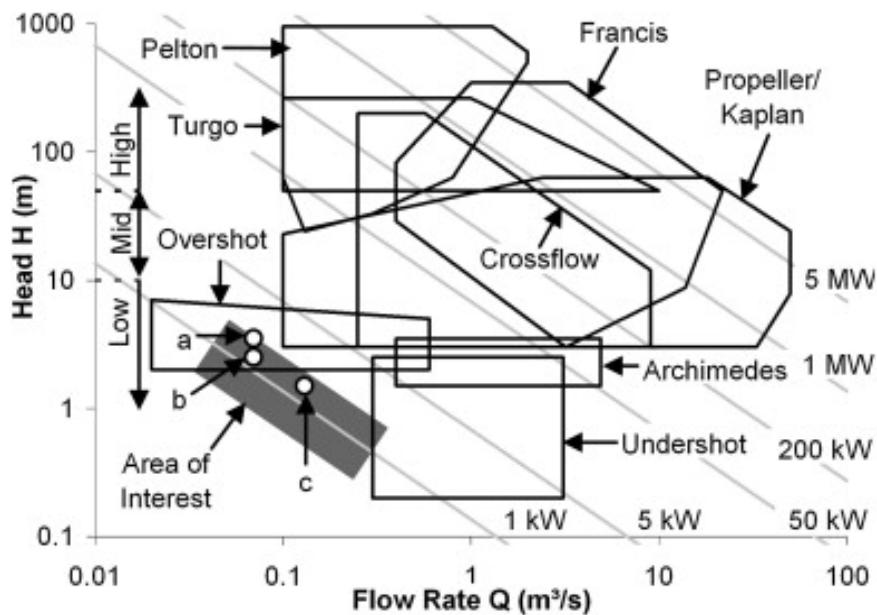

Fig. 4. Head and discharge relationship [13].

## 4. RESULT AND DISCUSSION

### 4.1 Lithology as a Foundation

From Appendix 3, the riverside plains in the south are dominant with claystone (yellow), while in the north, it is mainly carbonate siltstone (green). This indicates that the south is more suitable for the construction of MHPP than the north. Furthermore, the southern areas are closer to the residential area than the northern. Therefore, based on the classification of rock mass rating (RMR) using uniaxial compressive strength (UCS), the granodiorite is a hard rock, and its UCS ranges between 100 - 250 MPa, limestone between 25 - 50 MPa, and claystone 5 to 25 MPa [25]. This is in line with the results obtained by a previous study [26] where rocks with compressive strength above 100 MPa withstand both vertical and horizontal vibration. Meanwhile, rocks less than 25 MPa risk subsidence due to internal friction or swelling of clay minerals [27].

### 4.2 The Distance of the River to a Potential Power Plant Location

From Appendix 4, ArcGIS has visualized the river's distance as a potential MHPP site into three: red colour for distance < 100 m with a score of 1.32, yellow for 100-200 m with a score of 0.88, and green for above 200 m with a score of 0.44. ArcGIS visualizations have accuracy with a reading category of  $\pm 8$  m (tides.big.go.id).

### 4.3 River Slope

From Appendix 5, the river slope within the classification 21% to 100% (steep) is dominant in the south. Meanwhile, in the north, the river slope within 0 to 7% (almost flat to gently sloping) is dominant. This indicates that southern areas are more suitable for the construction of MHPP than northern. Furthermore, in southern areas, the Kikim river morphometry in several locations has steep slope angles ranging between 16 and



35°. Therefore, these conditions are suitable for the penstock pipe of MHPP, as its potential is high [28][24].

**4.4 Results of the Assessment of AHP Methods**

Figure 5 shows the results of the assessment using the AHP method. From these results, it was found that the lowest value is 0.99 and the highest is 2.97, where the areas of a higher value are good areas for the construction of MHPP. The weighting scores between 0.99 to 2.97 are classified into three categories: 0.99 to

1.65 is not ideal (green zone); 1.66 to 2.31 is less ideal (yellow zone); and 2.32 to 2.97 is ideal (red zones).

Based on the AHP assessment, three locations with values between 2.32 and 2.97 are ideal locations for MHPP (see Figure 5-b to d). Figure 5 b-d are the results of direct observation of the location which involved AHP assessment of the river morphometry directly. From the observation, Figure 5-d is a good location due to its deep, wide river conditions, with sufficient water velocity, and a head (elevation) of 4 m. Figure 6 is a zoom-in of the location at a blue box in Figure 5-a.

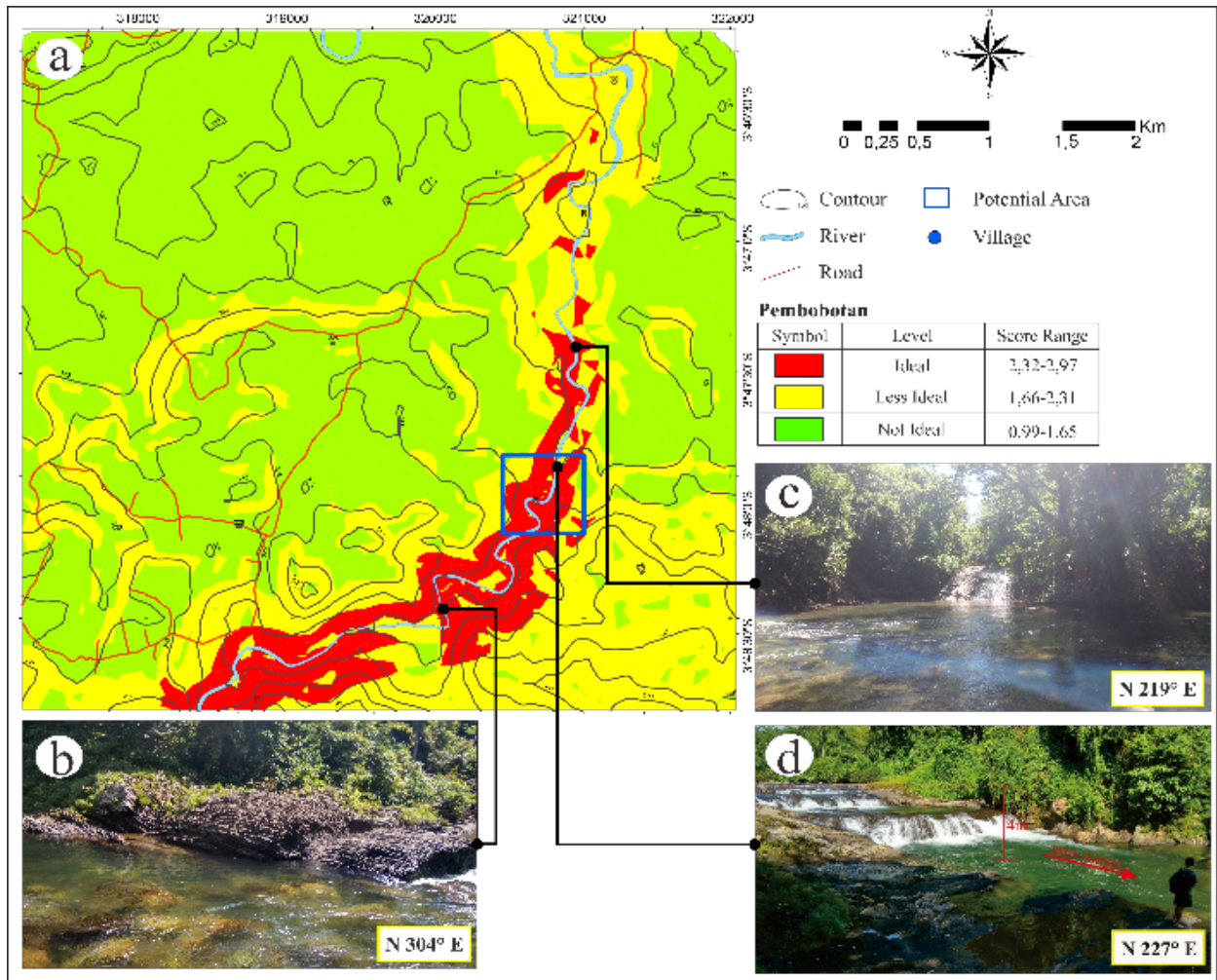

**Fig. 5. The assessment results of the location of the micro-hydro potential.**



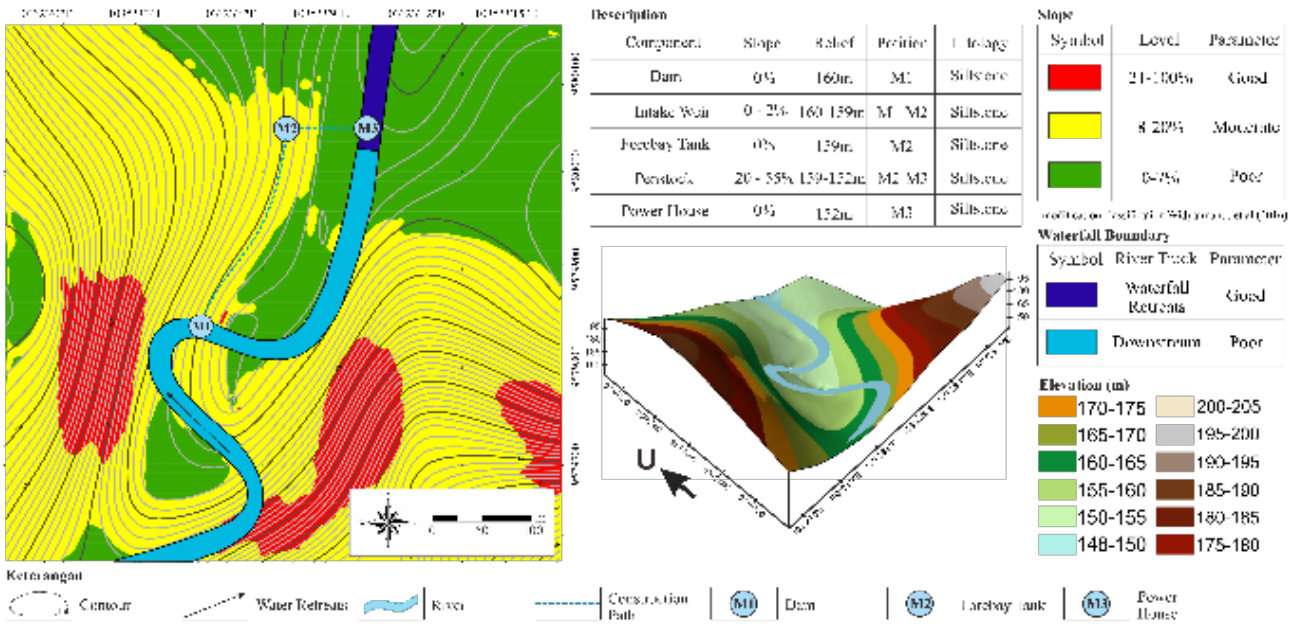

Fig. 6. Analysis of the position of the components of MHPP.

Based on geological analysis such as river slope and shape (elevation condition), MHPP components' layout can be adjusted (Figure 6).

The Kikim river has many small-scale waterfalls (Figure 5-d) which are favorable for MHPP implementation. From Figure 5-d, the head (elevation) of the waterfall is ± 4 m. A field measurement of the

river's cross-section area is 12.91 m<sup>2</sup>, while the width is ± 20.5 m and an average height of ± 0.61 m (see Figure 3). Table 6 shows the average local water velocity data and the average stream velocity of ± 0.26 m/s, as seen in Table 4. Therefore, the discharge of the river is 3.19 m<sup>3</sup>/s.

Table 4. Average local water velocity at twelve locations.

Velocity (m/s)	Times			Average
	1	2	3	
v <sub>1</sub>	0.10	0.20	0.10	0.13
v <sub>2</sub>	0.20	0.20	0.20	0.20
v <sub>3</sub>	0.20	0.30	0.30	0.27
v <sub>4</sub>	0.20	0.30	0.30	0.27
v <sub>5</sub>	0.20	0.30	0.20	0.23
v <sub>6</sub>	0.30	0.40	0.30	0.33
v <sub>7</sub>	0.30	0.30	0.30	0.30
v <sub>8</sub>	0.30	0.10	0.30	0.20
v <sub>9</sub>	0.40	0.30	0.30	0.33
v <sub>10</sub>	0.20	0.30	0.30	0.27
v <sub>11</sub>	0.30	0.20	0.20	0.23
v <sub>12</sub>	0.20	0.20	0.10	0.17
Average				± 0.26

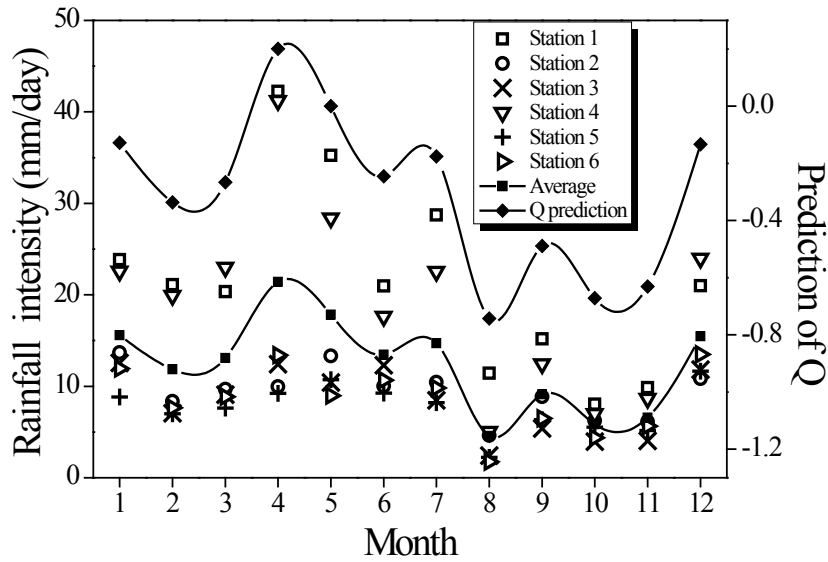

Fig. 7. Rainfall intensity in Lubuk Tuba village.

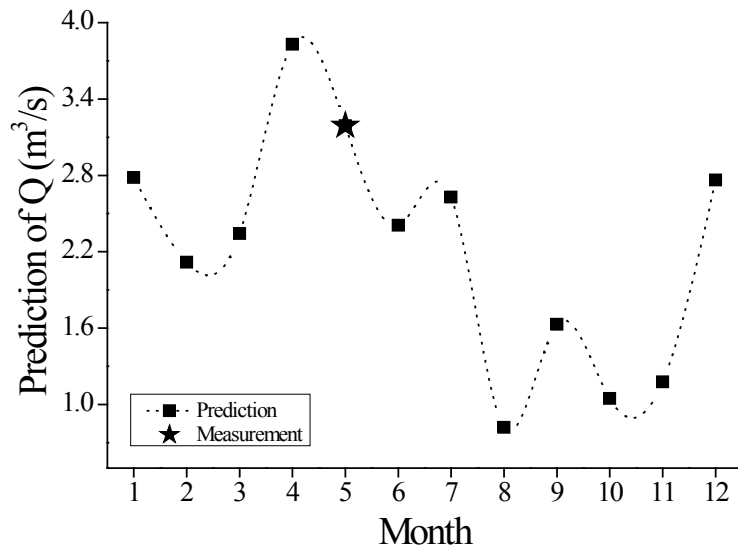

Fig. 8. Prediction of Q in one year.

Rainfall every month of the year in an area is certainly unstable, therefore the prediction of discharge (Q) using six data from the Meteorology Climatology and Geophysics Council (BMKG) of Republic of Indonesia (see Figure 6) [29]. In Figure 5-d and 7, the highest discharge (Q) is estimated to occur in April at 3.83 m<sup>3</sup>/s (20% from measurement results), while the lowest discharge (Q) is to be seen in August at 0.83 m<sup>3</sup>/s (74.32% from measurement results). Based on Figure 8, to anticipate the turbine not operating due to lack of input power (less discharge), the maximum exploitable discharge is 0.83 m<sup>3</sup>/s. Thus, hydropower potential in the Kikim river is predicted using Equation 6 of 32.15 kW, categorized as micro-hydro.

**4.6 Assessment of Micro-hydro Technology**

The Kikim river potential of 32.15 kW can supply electricity to 35 households with 50% efficiency and

power 0.45 kW/house (0.45 kW is a minimum kWh meter owned by the National Electric Company (PT. PLN) of Indonesia). Based on Figure 3, for a discharge (Q) of 0.83 m<sup>3</sup>/s and available head (h) of 4 m, there are three suitable turbines: propeller, Kaplan, and crossflow turbine (CFT). The propeller and Kaplan turbines are similar, Kaplan turbines are usually applied to hydropower on mini scales, as its construction is more complex (has an adjustable guide vane and blade) [30][31]. Hence, in consideration of investment costs, the propeller turbines and CFT have a good agreement for micro-scale.

The propeller is a reaction turbine (it absorbs the kinetic and pressure energy of water), and has stable performance because of a wide specific speed (Ns) range of 300 to 1000 m-kW [12]. Hence these turbines are often proposed as independent power plants for remote areas in several developing countries such as

Cameroon [3], Honduras [7], Laos [5], Rwanda [6],[32], and others. The propeller turbine was recommended because the potential head is fully utilized (minimum head losses, see Figure 9-a). Since the draft tube is a device converting the kinetic energy loss of water into potential energy pressure, it increases runner torque [33]. This turbine's disadvantage is its unfriendliness to the environment, as the high runner rotation makes the aquatic biota passing through it to die. Furthermore, this turbine's maintenance is categorized as difficult and has to be maintained daily, as its rotation is sensitive to the garbage and other objects passing through it [34].

The CFT is an impulse turbine that absorbs the kinetic energy of water converted by nozzle [35]. Based on Figure 4, the CFT is effective in medium to high head (5 to 100 m) [13]. However, it is often used in remote areas due to its operation at high discharge deviation and low head condition (<5 m) [13],[36],[37]. Additionally, this turbine absorbs energy in two

successions, called stage 1 and 2. The CFT is sensitive to the garbage and other objects (like propeller turbine) as they inhibit runner rotation.

This study agrees with the previous study [13] that the efficiency of the design and performance of CFT was lower compared to the propeller turbine. Since the position of the CFT has to be above the tailrace (see Figure 9-b). The advantage of using CFT lies in its civil construction is simpler than propeller turbines, where the dam can directly access the penstock pipe through the turbine system (See Figure 9-b). Unlike the propeller turbine, an open channel and basin are needed to use the turbine system. Furthermore, the CFT is rarely in demand due to the investment cost being higher than propeller turbines. In Indonesia, the per kW crossflow turbine is  $\pm$  USD 4000 while the propeller is  $\pm$  USD 2300, as the runner manufacturing process is difficult and lengthy due to its hand use (not mechanized).

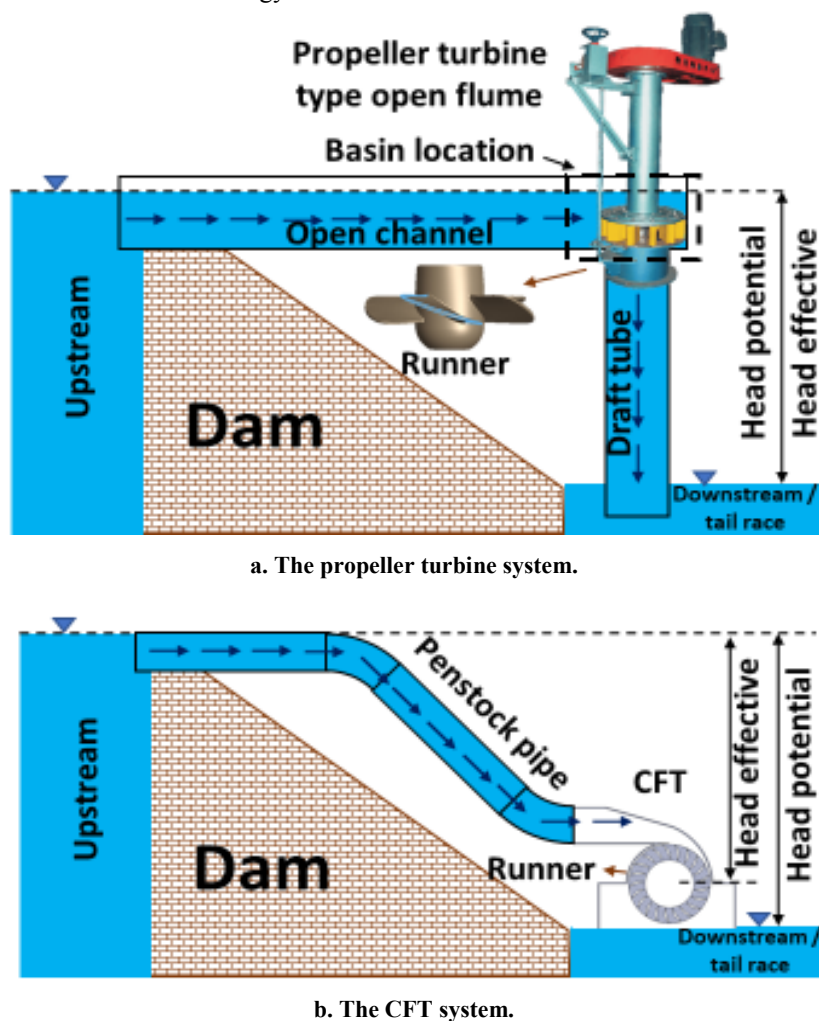

Fig. 9. Schematic of micro-hydro turbine type propeller and crossflow.

## 5. CONCLUSION

The determination of an ideal micro-hydro potential location involves the geoscience aspects of lithology, morphometry, and topography approaches, which

depends on the AHP assessment method. This geoscience approach helps to visualize case study areas with accuracy and precision. The advantage is that there is no need for lengthy observations and measurements along any river, as it helps to ascertain which one is

ideal. Therefore, the application of the AHP method in determining the ideal MHPP location saves cost, effort, and time.

The surface mapping and GIS results show that the ideal zone has good waterfall height (potential head) and plain with hard rock types (granodiorite). From the field observations, the waterfall or potential head (h) was 4 m, and discharge (Q) was 0.83 m<sup>3</sup>/s, the hydropower potential was 32.15 kW and is categorized as a micro-scale. In consideration of energy losses and investment costs, the propeller turbines are suggested in this case. Furthermore, the potential hydropower of the Kikim river of 32.15 kW can supply electricity to 35 households with 50% efficiency and 0.45 kW/house.

### ACKNOWLEDGEMENT

The authors said thanks to Rahmat Alfath as a surveyor (collecting data), Try Saputra from PT. Sriwijaya Bara Priharum, which supports measuring instruments, and Universitas Sriwijaya for facilities software and desktop.

### REFERENCES

- [1] The World Bank, 2019. Access to Electricity (% of Population). Geneva, Switzerland.
- [2] Adanta D., Budiarmo, Warjito, and Siswantara A.I., 2018. Assessment of turbulence modeling for numerical simulations into pico hydro turbine. *Journal of Advanced Research in Fluid Mechanics and Thermal Sciences* 46: 21–31.
- [3] Ho-Yan B., 2012. Design of a low head pico hydro turbine for rural electrification in Cameroon. The University of Guelph.
- [4] Adhikari P., Budhathoki U., Timilsina S.R., Manandhar S., and Bajracharya T.R., 2014. A study on developing pico propeller turbine for low head micro hydropower plants in Nepal. *Journal of the Institute of Engineering* 9(1): 36–53.
- [5] Vicente S. and H. Bludszuweit, 2012. Flexible design of a pico-hydropower system for Laos communities. *Renewable Energy* 44: 406–413.
- [6] Pigaht M. and R.J. van der Plas, 2009. Innovative private micro-hydro power development in Rwanda. *Energy Policy* 37(11): 4753–4760.
- [7] Thomas B., 2011. Pico-hydropower franchising in rural Honduras. *International Journal for Service Learning in Engineering, Humanitarian Engineering and Social Entrepreneurship* 6(1): 46–63.
- [8] Timilsina G.R., 2018. How would cross-border electricity trade stimulate hydropower development in South Asia? Washington, D.C.
- [9] Tang S., Chen J., Sun P., Li Y., Yu P., and Chen E., 2019. Current and future hydropower development in Southeast Asia Countries (Malaysia, Indonesia, Thailand and Myanmar). *Energy Policy* 129: 239–249. doi: <https://doi.org/10.1016/j.enpol.2019.02.036>.
- [10] Guiamel I.A. and H.S. Lee, 2020. Potential hydropower estimation for the Mindanao river basin in the Philippines based on watershed modelling using the soil and water assessment tool. *Energy Reports* 6: 1010–1028. doi: <https://doi.org/10.1016/j.egy.2020.04.025>.
- [11] International Hydropower Association, 2019. The 2019 Hydropower Status Report Offers Insights and Trends on the Hydropower Sector. London.
- [12] Syah A., 2017. *Manual Pembangunan PLTMH - Tri Mumpuni*. Jakarta: Japan International Cooperation Agency.
- [13] Williamson S.J., Stark B.H., and Booker J.D., 2014. Low head pico hydro turbine selection using a multi-criteria analysis. *Renewable Energy* 61: 43–50. doi: 10.1016/j.renene.2012.06.020.
- [14] Haidar A.M.A., Senan M.F.M., Noman A., and Radman, T., 2012. Utilization of pico hydro generation in domestic and commercial loads. *Renewable and Sustainable Energy Reviews* 16(1): 518–524.
- [15] Febriansyah D., Budiarmo, Warjito, Watanabe K., and Adanta D., 2018. Storage system manufacturability, portability and modularity for a pico hydro turbine. *Journal of Advanced Research in Fluid Mechanics and Thermal Sciences* 2(2): 209–214.
- [16] Badan Pusat Statistik Republik Indonesia (Agency of Central Statistics Republic of Indonesia) - Lahat District. Kecamatan Pseksu Dalam Angka 2019 (Pseksu Sub - District in Number 2019), Publication No. 16040.1907, Lahat, 2019. Cat. ID:1102001.1604122.
- [17] Widyatmanti W., Wicaksono I., and Syam P.D.R., 2016. Identification of topographic elements composition based on landform boundaries from radar interferometry segmentation (Preliminary study on digital landform mapping) in *IOP Conference Series: Earth and Environmental Science* 37(1): 12008. doi: <https://doi.org/10.1088/1755-1315/37/1/012008>.
- [18] Abe S., Van Gent H., and Urai J.L., 2011. DEM simulation of normal faults in cohesive materials. *Tectonophysics* 512(1–4): 12–21.
- [19] Khajavi N., Quigley M., and Langridge R.M., 2014. Influence of topography and basement depth on surface rupture morphology revealed from LiDAR and field mapping, Hope Fault, New Zealand. *Tectonophysics* 630: 265–284. doi: <https://doi.org/10.1016/j.tecto.2014.05.032>.
- [20] Meixner J., Grimmer J.C., Becker A., Schill E., and Kohl T., 2018. Comparison of different digital elevation models and satellite imagery for lineament analysis: Implications for identification and spatial arrangement of fault zones in crystalline basement rocks of the Southern Black Forest (Germany). *Journal of Structural Geology* 108: 256–268. doi: <https://doi.org/10.1016/j.jsg.2017.11.006>.



- [21] Malczewski J. and C. Rinner, 2015. *Multicriteria decision analysis in geographic information science*. Springer.
- [22] Barelli L., Liucci L., Ottaviano A., and Valigi D., 2013. Mini-hydro: A design approach in case of torrential rivers energy. *Energy* 58: 695-706.
- [23] Saaty T.L., 2008. Decision making with the analytic hierarchy process. *International Journal of Services Sciences* 1(1): 83–98.
- [24] Signe E.B.K., Hamandjoda O., and Nghanou J., 2017. The methodology of feasibility studies of micro-hydro power plants in Cameroon: Case of the micro-hydro of KEMKEN. *Energy Procedia* 119: 17–28.
- [25] Bieniawski Z.T., 1989. *Engineering rock mass classifications: A complete manual for engineers and geologists in mining, civil, and petroleum engineering*. John Wiley & Sons.
- [26] Nicieza C.G., Fernández M.I.Á., Díaz A.M., and Vigil A.E.Á., 2006. Modification of rock failure criteria considering the RMR caused by joints. *Computers and Geotechnics* 33(8): 419–431.
- [27] Chen J., Li X., Zhu H., and Rubin Y., 2017. Geostatistical method for inferring RMR ahead of tunnel face excavation using dynamically exposed geological information. *Engineering Geology* 228: 214–223.
- [28] Johansson M. and T. O'Doherty, 2017. Feasibility of micro-hydro schemes in South Glamorgan, Wales. *Energy Procedia* 142: 309–314.
- [29] Faqih A., 2017. A statistical bias correction tool for generating climate change scenarios in Indonesia Based on CMIP5 datasets. In *IOP Conference Series: Earth and Environmental Science* 58(1): 12051.
- [30] Harinaldi and Budiarso, 2015. *Sistem Fluida (Prinsip Dasar dan Penerapan Mesin Fluida, Sistem hidrolik dan Sistem Pnuematik)*. Jakarta: Erlangga.
- [31] Nechleba M., 1957. *Hydraulic Turbines, Their Design, and Equipment*.
- [32] Gladstone S., Tersigni V., Francfort K., and Haldeman J. A., 2014. Implementing pico-hydropower sites in rural Rwanda. *Procedia Engineering* 78: 279–286.
- [33] Adanta D., Budiarso, Warjito, and Mahlia T.M.I., 2019. Investigation of the effect of gaps between the blades of open flume pico hydro turbine runners. *Journal of Mechanical Engineering and Sciences* 13(3): 5493–5512. doi: <https://doi.org/10.15282/jmes.13.3.2019.18.0444>.
- [34] Nasution S.B., Budiarso, Warjito, and Adanta D., 2018. A comparison of openflume turbine designs with specific speeds (Ns) based on power and discharge functions. *Journal of Advanced Research in Fluid Mechanics and Thermal Sciences* 51: 53–60.
- [35] Siswantara A.I., Budiarso, Prakoso A.P., Gunadi G.G.R., Warjito, and Adanta D., 2018. Assessment of turbulence model for cross-flow pico hydro turbine numerical simulation. *CFD Letters* 10: 38–48.
- [36] Mockmore C.A. and F. Merryfield, 1949. *The Banki water-turbine*, vol. 25, no. February. Engineering Experiment Station (unpublished). Oregon State System of Higher Education, Oregon State College Corvallis, Ore, USA.
- [37] Sammartano V., Aricò C., Carravetta A., Fecarotta O., and Tucciarelli T., 2013. Banki-Michell optimal design by computational fluid dynamics testing and hydrodynamic analysis. *Energies* 6(5): 2362–2385.



APPENDIX

1. Distribution of rocks in the case study area

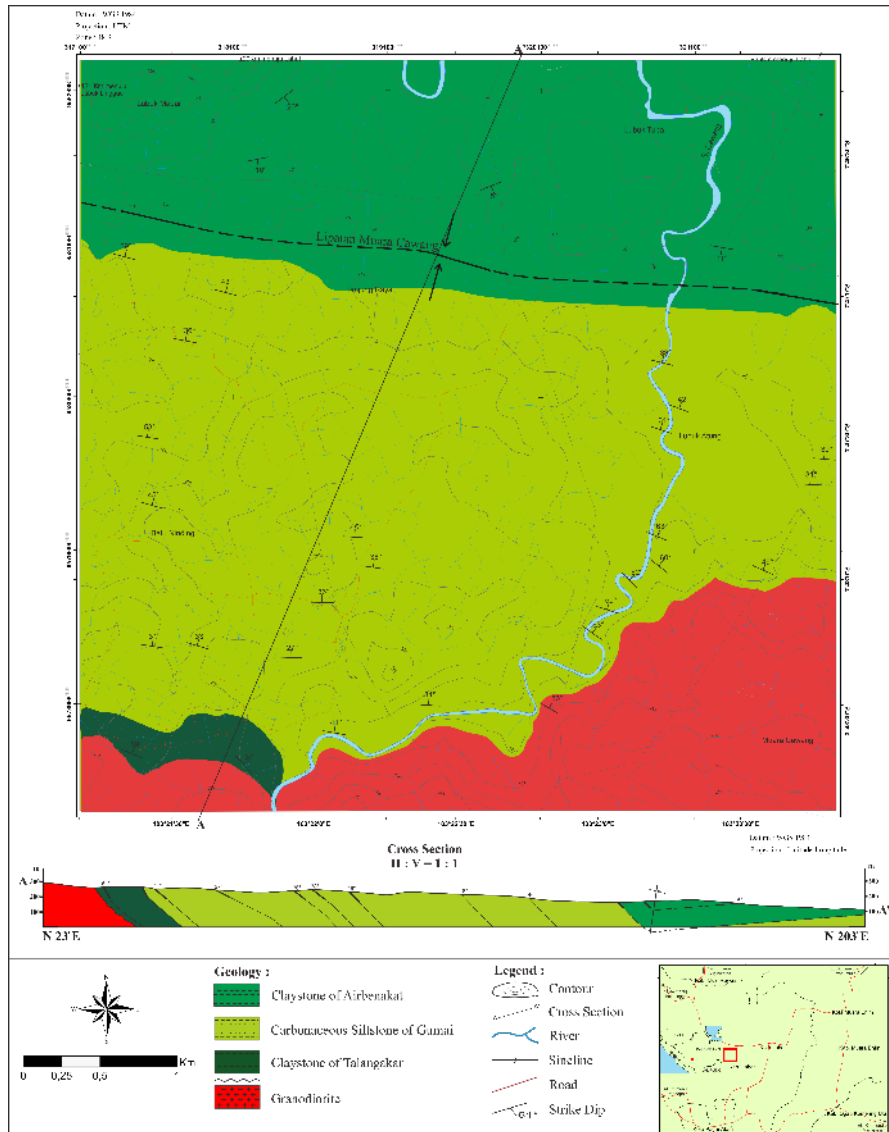

2. Visualization of slope map in the case study area

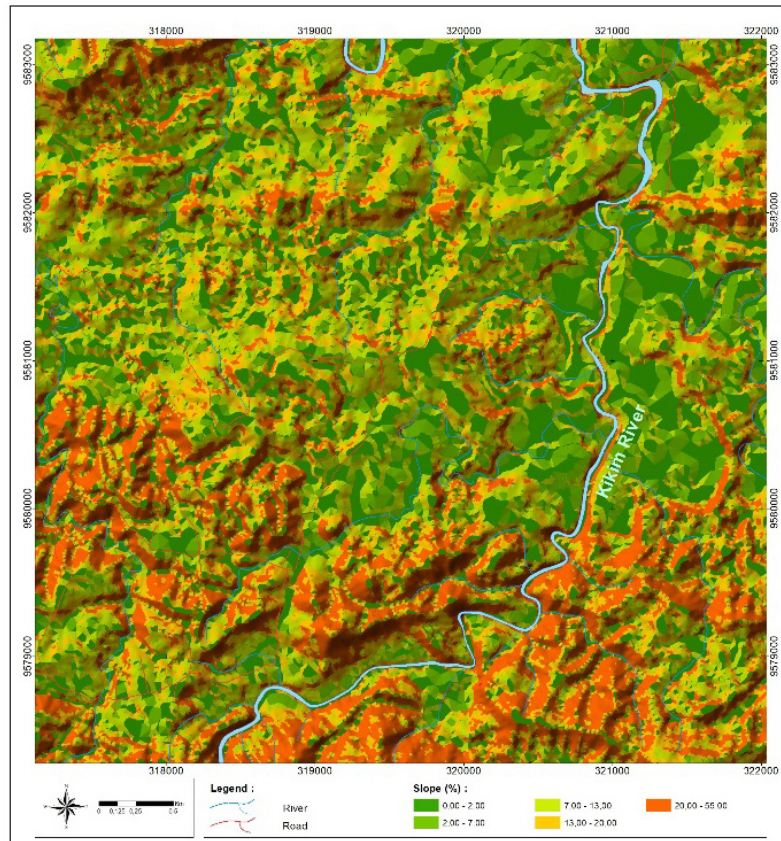

3. Assessment results of lithology aspect





4. Assessment results of the aspect of river distance to a potential power plant location

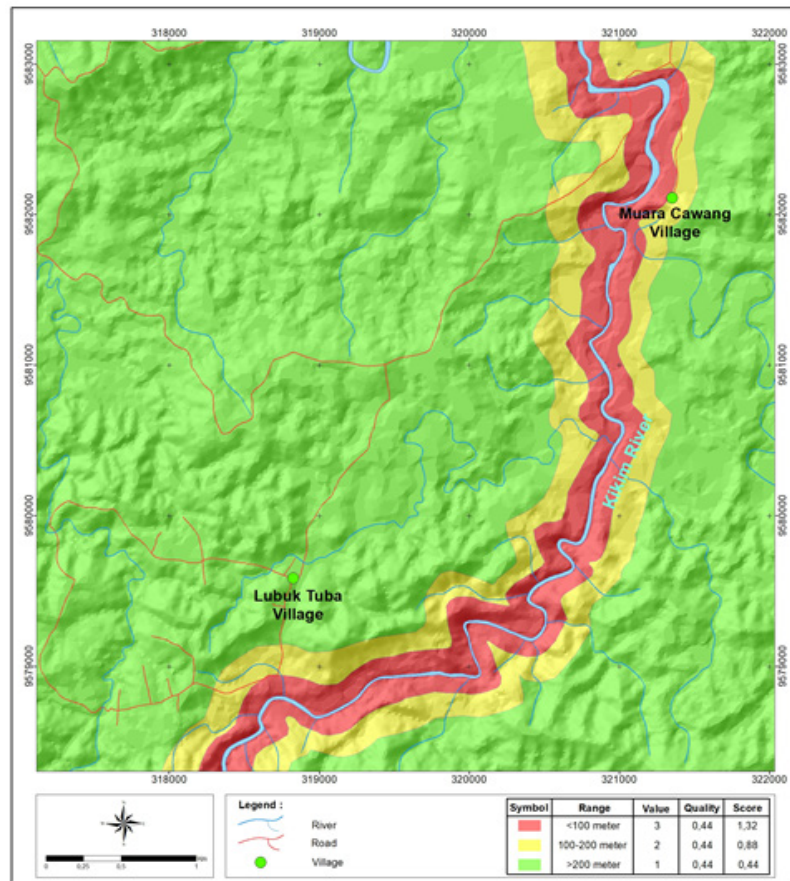

5. Assessment results of river slope aspect







[www.ericjournal.ait.ac.th](http://www.ericjournal.ait.ac.th)

## Solution to Optimum Gas Well Operation Problem for Developing Countries

Kamil K. Mamtiyev\*, Tarana A. Aliyeva\*, and Ulviyya Sh. Rzayeva<sup>†, 1</sup>

**Abstract** – The objective of the proposed research is the analysis of the resource problem in the development of gas generation - one of the urgent tasks for both Azerbaijan and Bangladesh; the subject of research is a numerical solution of the problem of optimum management of gas wells. The solution to the problem is based on the approximation of a partial differential equation by systems of ordinary differential equations. Particular attention is paid to the numerical solution of the optimal control problem associated with these systems based on the Pontryagin's maximum principle. To solve the problem, a linearization method and implicit finite difference schemes for solving a nonlinear equation are proposed. The calculation of technological modes of wells operation by adjusting the bottomhole pressure within certain limits is based on the results of theoretical and experimental studies. This study presents an approach to solving the energy problem, which is especially relevant for developing countries.

**Keywords** – energy shortages, gas condensate fields, gradient projection method, method of straight lines, optimum gas well management.

### 1. INTRODUCTION

Geopolitical changes in the modern world inevitably affect all spheres of the states, largely determining the architecture of international relations, including in the energy sector. Both Azerbaijan and Bangladesh are characterized by a number of interrelated problems in the field of energy, climate, and environment. In addition to the quantitative deficit, the electric power industry of these countries is characterized by various qualitative problems: low technical efficiency of generators due to the use of outdated technologies and equipment condition (typical electrical efficiency of gas generation is 23 - 29% versus 50% for modern combined cycle plants); poor current quality (typical frequency fluctuation range of ~ 1.5 Hz is above the limit levels of modern power systems); significant energy losses; failure to comply with the terms and order of scheduled preventive maintenance (due to deficiencies in legislation and low efficiency of supervision) and so on [9]. Today, about 80% of electricity generation is provided by natural gas generation, and it is assumed that gas generation will remain the main one for a long time [16].

In modern conditions characterized by rising energy prices, the efficiency and cost-effectiveness of the operation of gas fields and underground gas storages are important factors in reducing costs and increasing the reliability of gas supplies to consumers. An important

scientific and technical problem of field development is to ensure high levels and rates of hydrocarbon production with the most complete extraction from the bowels, as well as the high technical and economic performance of gas-producing enterprises. Therefore, improving the technology for developing gas and gas condensate fields is an urgent and important task for the oil and gas industry.

The goal of this work is to improve the quality of numerical solutions to optimal control problems for nonlinear systems with distributed parameters through the Pontryagin's maximum principle. This goal is achieved without the need to consider the conjugate boundary value problem for partial differential equations.

All of the above determine the structure of the article, which consists of six main parts. The introduction substantiates the relevance of the topic and formulates the objectives of the study. The methodology section describes the applied research methods, substantiates the scientific novelty and practical value of solving the problem under consideration. Further, a review of literature is presented. The main part of the study includes the theoretical and practical part of constructing the mathematical tools of the optimal control problem and determining the technological mode of gas well operation. The study is completed by discussion and conclusion, constituting findings on the research.

### 2. RESEARCH METHODOLOGY

Analysis of the problem under consideration makes it possible to single out optimization of gas resource management in individual countries as a component for the both regions. The stated topic is a complex problem, which determines the complex nature of the methodological basis of the study. To consider the topical aspects of the problem, the authors use a

\*Department of Digital Economics and ICT Azerbaijan State University of Economics, Istiglaliyyat Str., 6, Baku, Azerbaijan.

<sup>†</sup>Azerbaijan State University of Economics, the Center of Digital Economy.

<sup>1</sup>Corresponding author;

Tel: + 99450 2229921.

E-mail: [ulviyya.rzayeva@unec.edu.az](mailto:ulviyya.rzayeva@unec.edu.az)



systematic approach without touching upon the political and economic aspects.

Mathematical models of most economic objects and processes are nonlinear. Many articles are devoted to the optimal control of wells' technological regimes. The article discusses the problem of optimal control of gas fields' return by Pontryagin's maximum principle. Nonlinear systems are presented with distributed parameters, and there is no special need to consider the conjugate boundary value problem for partial differential equations. The main numerical method used in this work is the gradient descent method. The gradient descent method is actively used in computational mathematics not only for the direct solution of optimization (minimization) problems, but also for problems that can be rewritten in the optimization language (solving nonlinear equations, finding equilibria, inverse problems, *etc.*). However, the fundamental methodological difference between the proposed method and the others is that in this work an attempt is made to study the convergence rate in terms of the functional of the iterative process using the example of only gradient descent.

The scientific novelty of this work lies in the development and justification of a method on solving the optimal control problem for systems with distributed parameters. In the problem considered, the technological mode of operation of gas wells is determined by regulating the bottomhole pressure within certain limits. The proposed approximate solution of the posed boundary value problem is found using the straight-line method.

The purpose of the paper is to prove convergence on functional for which the approximate optimal control is found minimizing. The gradient projection method is used with a special choice of step, and there is no tendency to "hopper agitation". In a short time, a convergent minimizing sequence is obtained in the control space.

When performing the work, methods of the theory of optimal control and linear programming, various linearization methods, and implicit finite difference schemes for solving the nonlinear equation are used. The experimental material is based on calculations performed using actual data on gas storage facilities, as well as on the experience of implementing technical solutions developed and justified in this work.

The validity and reliability of the results are ensured by the correctness and completeness of the models used, the convergence of computational algorithms, the results of testing algorithms and programs, and experimental studies.

### 3. LITERATURE REVIEW

As part of gas production technology, gas wells are the most numerous objects. Complicating conditions for gas production, increasing requirements for the quality of gas field management, improving field development

indicators have led to the urgent need for more active implementation of automated gas well management as part of information-measuring and control systems.

However, research studies have not yet sufficiently reflected the decision-making methods for managing gas wells. The complexity of this task lies not only in a large number of wells at one control object but also in the interdependence of the wells' operation. This interdependence remains notoriously complex: the interaction between the wells occurs both through the gas collection and transportation system, and through the gas-bearing stratum. In addition, there are factors of uncertainty in the parameters of these objects. Note that after the emergence of the famous Pontryagin's maximum principle [15] optimization methods have found wide applications in modelling and solving various problems of developing oil and gas fields.

To obtain the characteristics of the regimes for maintaining the maximum allowable pressure gradient on the walls of the wells, Zakirov [25] uses two equations - the nonlinear law of resistance for the filtration rate and the equation of gas inflow to the bottom of the well with a nonlinear law of resistance.

In the paper [8] the problem of finding a rational option for the development of a gas field is considered and an algorithm for its solution using the gradient method is proposed. An example of solving the problem for a typical gas field in Western Siberia is given. The article [3] considers the task of determining the technological modes of well operation. According to the authors, these modes provide optimal technical and economic indicators of development and the most complete extraction of oil or gas from the bowels. The problem with the condition of two-phase filtration is reduced to the task of optimal control of filtration flows in the reservoir. In survey paper [21] the problem of mathematical modelling of the process of extracting oil from heterogeneous formations and methods of solution are considered. The task of optimal regulation of the oil recovery process is posed and an assessment of the main factors affecting this process is given. In the manuscript [1] the problem of optimal placement of oil reservoir wells and flow rate management is investigated. Mathematically, this problem is a parametric task of optimal control of a distributed system concentrated by sources, described by differential equations in partial derivatives.

In his next work, Zakirov [26] considers the problem of maximizing oil production from a multilayer field with a single grid of production wells and separate grids of injection wells. To solve the problem, methods of the theory of optimal control are used. In the paper [18] the model of the functioning of a gas field with interrelated wells is investigated. The optimal control problem is posed and solved on an infinite interval. Tugov in [22] describes the search for the optimal control action on the oil mixture in a primary preparation separation unit using the acoustic treatment. The application of the maximum principle, which allows

determining the values of the control actions on the oil mixture, is considered; experiments to study the effect of ultrasonic exposure on the separation process are conducted under laboratory conditions.

It should be noted that in the two last decades, completely new approaches based on the use of genetic algorithms and neural networks have appeared to solve optimization problems associated with the design and development of gas and oil fields. For example, a study [24] aims to represent the body of knowledge on evolutionary computing used in the field of exploration and production in the oil and gas industry. It also describes the structure of evolutionary engineering systems in determining reservoir characteristics. In the manuscript [27] various methods are compared with work of genetic algorithms in the field we are studying. The authors investigate the ant colony optimization (ACO) method, which has shown excellent properties in optimizing water distribution networks. The study [13] presents a new methodology for predicting fluid flow behavior using the artificial neural network. The developed methodology allows predicting a wide variety of cost items, ranging from the pressure at the inlet to the throttle up to the size of the throttle. The accuracy of the developed model is proved by empirical correlations.

Soemardan in [20] develops economics-mathematical model for optimizing gas production on the example of research of the Matindok field. The author analyses marginal costs in determining the optimal level of gas production. The results obtained show that the optimal resource extraction rate is in direct proportion to its price and transportation time. Namdar in [14] claims that the increased speed and accuracy in solving gas distribution optimization problems are determined by the nature of the allocation of either reef structures' form and the structural-tectonic factor, including the presence of high-amplitude shafts and flexures. The optimization solution consists of two successive stages: (1) fitting the gas lift productivity curve (gas lift modelling) and (2) optimizing the gas distribution between the wells. The results obtained allow substantiating the optimal technology for conducting research and interpreting the results to diagnose the proportion of cracks in the tributary with the goal of uniform reservoir development. Janiga in [6] describes the non-uniformity of pressure reduction in interlayers with different filtration-capacitive properties during the development of a gas condensate field. The result of an uneven pressure reduction in the reservoir is the occurrence of interstratal flows of the gas-condensate mixture even in the presence of a slight hydrodynamic contact between the layers. The proposed approach to the restoration of reservoir properties in the interwell space using reference points has been tested on synthetic models. It is shown that the application of the proposed approach allows saving geological information in the process of refining the model.

The article [4] presents the modern achievements of gas lift technology and promising directions for the

development of this method for well operation. The authors consider the aspects of establishing the necessary technological mode of operation of the wells, taking into account the current state of the reservoir-well system, as well as the planning of geological and technical measures aimed at intensifying the selection of reservoir fluids. To analyse the information, physical and mathematical models are used in the online mode; this makes it possible to identify the dynamic features of changes in the analysed parameters and the presence of periodic self-organizing processes.

Purification of natural and other gases from hydrogen sulphide can be carried out by different methods. The choice of the process of natural gas purification from sulphur compounds in each case depends on many factors, the main of which are: the composition and parameters of the feed gas, the required degree of purification and the use of commercial gas, the availability and parameters of energy resources, production waste, *etc.* An analysis of world practice accumulated in the field of natural gas purification shows that absorption processes for processing large gas flows using chemical and physical absorbents and their combinations are the main ones. Shang in [17] tests a stationary simulation modelling the process of natural gas purification from high sulphur content using ProMax. Using the backpropagation neural network based on the analysis of the integrated distribution of energy consumption, seven main operating parameters of the cleaning process are determined. The article [2] uses the PSA - particle swarm algorithm to determine the intervals for filling wells between sampling points in a synthetic reservoir with constant fluid measurement. Real-time image registration provides the necessary information about the structure of the collector and, ultimately, helps to keep the trajectory in the most productive zone. The objective function in this study is the net present value of the asset (reservoir). The effective Monte-Carlo method presented in the article [7] is an optimization plan of the gas condensate field development, taking into account the distribution of fluid backstops in terms of reliability, and allows minimizing geological risks and uncertainties during well construction. The work studies the solubility kinetics of various types of clays in acidic compositions and their components depending on the concentration of reagents, temperature, and duration of the experiment.

Despite a lot of research in this direction, the known methods are not adapted to develop optimal solutions for managing gas wells in real-time. Thus, the control and management of gas wells, taking into account the interaction of wells with other elements of the gas production technological complex in the face of parameters' uncertainty, remains an urgent task.

#### 4. PROBLEM STATEMENT

The choosing technological mode of gas well operation is one of the most important decisions made during the

mining and management of field development. Generally, the technological regime of well operation is understood as the regulation of the well flowing  $q(t)$  or pressure  $p_c(t)$  in the bottomhole zone. Conditions ensuring compliance with the rules relating protection of mineral resources and trouble-free operation of wells are supported with their help. One of the simplest technological modes of gas well operation is the maximum allowable depression mode. With growing depression, the flowing of the production well increases. This mode is mathematically written as  $p_{II}(t) - p_c(t) = \delta$ , where  $p_{II}(t)$  is the reservoir pressure in the zone of some well at time  $t$ ;  $p_c(t)$  is the bottomhole pressure in the same well at time  $t$ ;  $\delta$  is the allowable depression on the reservoir.

In this article, the technological mode of gas well operation is determined by adjusting the bottomhole pressure  $p_c(t)$  within certain limits. This task can be attributed to the class of optimal control problems for systems with distributed parameters. Relatively dimensionless quantities, it can be formulated as follows: operate the pressure  $p_c(t)$ , satisfying the inequality

$$0 < p_1 \leq p_c(t) \leq p_2 \leq 1 \quad (1)$$

in the time interval  $0 \leq t \leq T$ , where  $p_1$  and  $p_2$  are constants defined on the basis of technical and economic calculations so that the amount of gas produced from wells minimally deviates from its previously planned value  $q^*(t)$ . A quadratic functional is taken as a measure of such a deviation

$$F = \frac{1}{2} \int_0^T \left[ \frac{\partial p^2(0,t)}{\partial x} - q^*(t) \right]^2 dt \quad (2)$$

Here  $p(x,t)$  describes the distribution of gas pressure in the “reservoir”  $0 \leq x \leq 1$ , which, with the linear law of filtration, is a solution of the non-linear Leibenzon equation [10]:

$$\frac{\partial p}{\partial t} = \frac{1}{2} \cdot \frac{\partial^2 p^2}{\partial x^2} \quad (3)$$

under the following boundary conditions

$$p(x,0) = \text{const} = 1, 0 \leq x \leq 1, \quad (4)$$

$$p(0,t) = p_c(t), \frac{\partial p(1,t)}{\partial x} = 0, 0 < t \leq T, \quad (5)$$

where  $p_c(t)$  is a piecewise continuous function in the interval  $0 \leq t \leq T$ , and conditions (Equation 4) and the first condition in (5) are consistent:  $p_c(0) = 1$ .

Condition (4) is the initial one and means that at the initial moment of time the distribution law of the

reservoir pressure is known. The second condition in Equation 5 indicates the impermeability of the external boundary of the reservoir. Note that when solving some filtration problems at the outer boundary  $x=1$ , the reservoir pressure value  $p_{II}(t)$  is set, that is, the second condition in Equation 5 can be replaced by the condition  $p(1,t) = p_k(t)$ . Consider the differential equation

$$\frac{dy}{dt} = \frac{1}{2} \left[ \frac{\partial p^2(0,t)}{\partial x} - q^*(t) \right]^2, y(0) = 0, \quad (6)$$

related to functional (2). Then functional (2) is written as

$$F = y(T). \quad (7)$$

Thus, problem (1) – (5) is narrowed down to the problem of systems’ optimal control, the behavior of which is described by a set of differential equations in partial and ordinary derivatives. We note that optimal control problems associated with a more general boundary-value problem similar to (3) – (6) were first considered by Egorov [3] in the mid-60s of the last century, and the early 70s and subsequent years were the subject of research by many Russian and foreign authors.

Further, as such practically important problems appear the activation of research in this direction is reflected in [21]. In the paper [5] the control problem of the so-called noisy dynamic systems associated with obtaining an assessment of the state and parameters of the control object is considered. In the manuscript [3] the problem of dumping the oscillations of a system described by a combination of a wave equation and an ordinary differential equation of the second order is considered under the assumption that the control function and the object with lumped parameters act, respectively, on the left and right ends of the object with distributed parameters. The functions of the states of the system are connected through the boundary conditions for the wave equation. To solve the problem, the d’Alembert formula was used and, applying the method of straight lines, finite-dimensional approximations of the problem were constructed. Teymurov in [21] investigated the problem of optimal control of processes described by a combination of parabolic type equations and ordinary differential equations with controls of moving sources. The existence and uniqueness theorem of the solution was proved, the necessary optimality conditions were obtained in the form of point and integral maximum principles.

It is easy to see that when solving problems related to regulation in a given range of well production, ensuring depletion of a gas reservoir by a given point in time, the first condition in (5) should be replaced by the condition

$$\frac{\partial p^2(0,t)}{\partial x} = q(t), 0 < q_1 \leq q(t) \leq q_2, 0 \leq t \leq T \tag{8}$$

and instead of (2) minimize the functional

$$F = \frac{1}{2} \int_0^1 [p(x,T) - p^*(x)]^2 dx \tag{9}$$

where  $p^*(x)$  is the gas pressure over the reservoir, specified on the basis of technological considerations,  $q_1, q_2$  are constant values. Condition (8) shows that a well located at the “point”  $x = 0$  is operated with a production rate  $q(t)$ . A numerical solution to this problem was obtained in [12]. Instead of (2) we consider minimization of the functional

$$F = \frac{1}{2} \int_0^T [p(0,t) - p_3(t) - \delta]^2 dt \tag{10}$$

taking into account phase restrictions

$$p(0,t) > p_3(t) \tag{11}$$

where  $p_3(t)$  is the specified pressure in the bottomhole zone of the well, and  $\delta$  is the allowable depression on the formation and is a given number. Then we have to deal with the control task of choosing the technological mode of operation of gas wells that provides the maximum allowable depression on the formation [26].

**5. NUMERICAL SOLUTION OF PROBLEM (1), (3) – (7)**

Due to the impossibility of obtaining an analytical solution of the boundary value problem (3) – (6), although in [10] various linearization methods and implicit finite-difference schemes for solving the nonlinear equation (3) are proposed. An approximate solution to the boundary value problem (3) – (6) will be sought by the straight line method, replacing it at the grid nodes of the lines  $x_i = ih, i = 1, 2, \dots, n, (n+1)h = 1, x_0 = 0, x_{n+1} = 1$  by the system of differential-difference equations:

$$\begin{aligned} \frac{dz_i}{dt} &= \frac{1}{2h^2} [z_{i-1}^2 - 2z_i^2 + z_{i+1}^2], i = 1, 2, \dots, n, \\ z_0 &= p_c(t), z_{n+1} = z_n, \\ \frac{dy_n}{dt} &= \frac{1}{2h^2} [z_1^2 - p_c^2 - hq^*(t)]^2, \end{aligned} \tag{12}$$

with initial conditions

$$z_i(0) = 1, i = 1, 2, \dots, n, y_n(0) = 0 \tag{13}$$

where  $z_i(t) = p(x_i, t), i = 1, 2, \dots, n, y_n(t) = y(t)$ .

The system of differential-difference equations (12) is valid for all internal nodal points,  $x_i = ih, i = 1, 2, \dots, n$ , where  $h$  is the step along the

spatial coordinate. The approximating functional has the form:

$$F = y_n(T). \tag{14}$$

Therefore, using the method of straight lines, problem (1), (3) – (7) reduces to the optimal control problem for concentrated systems with a free right end [15]. Using a priori estimates known for systems of linear ordinary differential equations, it is easy to prove that the solution of the differential-difference system (12) – (13) converges as  $h \rightarrow 0$  with the speed  $O(h)$  to the solution of the boundary value problem (3) – (6), and functional convergence takes place.

We write the system of conjugate equations:

$$\begin{aligned} \frac{d\psi_1}{dt} &= \frac{\partial H}{\partial z_1} = -\frac{z_1}{h^2} [-2\psi_1 + \psi_2] + \\ &\frac{2z_1}{h^2} [z_1^2 - p_c^2 - hq^*(t)\varphi_n] \\ \frac{d\psi_i}{dt} &= -\frac{\partial H}{\partial y_i} = -\frac{z_i}{h^2} [\psi_{i-1} - 2\psi_i + \psi_{i+1}], \\ i &= 2, 3, \dots, n-1, \\ \frac{d\psi_n}{dt} &= -\frac{\partial H}{\partial y_n} = -\frac{z_n}{h^2} [\psi_{n-1} - \psi_n], \\ \frac{d\varphi_n}{dt} &= -\frac{\partial H}{\partial y_n} = 0, \end{aligned} \tag{15}$$

with conditions at the right end

$$\psi_i(T) = 0, i = 1, 2, \dots, n, \varphi_n(T) = 1 \tag{16}$$

where

$$\begin{aligned} H &= \frac{1}{2h^2} \sum_{i=1}^n \psi_i [z_{i-1}^2 - 2z_i^2 + z_{i+1}^2] + \\ &\frac{\varphi_n}{2h^2} [z_1^2 - p_c^2 - hq^*(t)]^2 \end{aligned} \tag{17}$$

is Hamilton - Pontryagin function of problem (1), (12) – (14).

Note that the system of Equations (15) – (16) with ordinary derivatives can be obtained directly and approximating the boundary value problem conjugate for (3) – (6) by the method of straight lines

$$\frac{\partial \psi}{\partial t} = -p(x,t) \cdot \frac{\partial^2 \psi}{\partial x^2}, \tag{18}$$

$$\psi(x,T) = 0, 0 \leq x \leq 1, \tag{19}$$

$$\psi(0,t) = -2\varphi(t) \left[ \frac{\partial p^2(0,t)}{\partial x} - q^*(t) \right], \tag{20}$$

$$\frac{\partial \psi(1,t)}{\partial x} = 0, 0 \leq t < T,$$

$$\frac{d\varphi}{dt} = 0, \varphi(T) = 1, 0 \leq t < T, \tag{21}$$

compiled on the basis of the stated in [23] general



approach used in deriving the formula for the gradient of functional (7). However, many authors prefer to consider the conjugate problem precisely for partial differential equations, since in this case the initial distributed system can be solved not only by the method of straight lines but also by any numerical methods, in particular, by an implicit difference scheme in combination with “walk-through” [23].

Considering that  $\varphi_n(t) \equiv \text{const} = 1$  from (17) we have:

$$\frac{\partial H}{\partial p_c} = \frac{1}{h^2} \left\{ \psi_1 - 2[z_1^2 - p_c^2 - hq^*(t)] \right\} p_c \quad (22)$$

To numerically solve problem (1), (12) - (14), we choose some initial control  $p_c^0(t)$  that satisfies (1), taking into account the conditions  $p_c(0) = 1$ . The Runge – Kutta method solves the Cauchy problem for the system of equations (12) – (13) and finds the values of the functions  $z_i(t), i = 1, 2, \dots, n, y_n(t)$  in the time interval  $0 \leq t \leq T$  and their values are remembered. Then, in the “opposite direction” of time, the Cauchy problem for the conjugate system (15) - (16) is solved, the coefficients of which are calculated along with the trajectories  $z_i(t), y_n(t)$ , and at each step of integration the values  $\partial H / \partial p_c$  are found. Further, new, improved controls at successive approximations are calculated by the formulas

$$p_c^{k+1}(t) = \begin{cases} p_c^k(t) - \delta p_c^k(t), & p_1 < p_c^k(t) - \delta p_c^k(t) < p_2 \\ p_1, & p_c^k(t) - \delta p_c^k(t) \leq p_1, \\ p_2, & p_c^k(t) - \delta p_c^k(t) \geq p_2 \end{cases} \quad (23)$$

taking into account the conditions  $p_c^k(0) = 1$ , where  $\delta p_c^k(t)$  is the control improvement change, which for a problem with a fixed left end, a free right end and in the absence of restrictions is usually constructed according to the scheme  $\delta p_c^k(t) = -\lambda_k F'(p_c^k(t))$ . In the paper [11] control is calculated in a special form according to the rule

$$\delta p_c^k(t) = \lambda \cdot \frac{\partial H^k(t) / \partial p_c}{\left| \frac{\partial H_0^k(t)}{\partial p_c} \right|}, k = 0, 1, 2, \dots \quad (24)$$

Here  $k$  is the iteration number,  $\partial H_0 / \partial p_c$  is the maximum value for  $\partial H / \partial p_c$ , taken in absolute value for  $0 \leq t \leq T$ , and  $\lambda > 0$  is the step size. Depending on the selection method, as a rule, various forms of first-order gradient methods are obtained. The iterative process (23) – (24) continues until one of the described in [21] criteria for ending the count are fulfilled; sometimes the number of iterations is predefined. To implement the above scheme, the program is compiled in QBasic.

The initial values of the parameters, one-

dimensional arrays for storing function values  $p_c^0(t), p_c^1(t), q^*(t), \partial H / \partial p_c, \delta p_c^k(t)$ , and two two-dimensional arrays for solutions of the approximating and conjugate systems are entered in the initial lines of the program. In the next lines, the system is approximated, the functional values are calculated, and a system of conjugate equations is solved in the opposite direction of time. For clarity, the following few lines of the program indicate the commands designed to determine the maximum element of the array  $\partial H / \partial p_c$ , calculate the new control  $p_c^1(t)$  and print the value of the functional, as well as the solution to the approximating system (12) – (13), corresponding to this control.

Note that in the process of calculations, as the need arises, some lines can be added to the program, allowing to trace the correctness of the intermediate calculations.

```

370 max = dhdp (0)
380 for j = 1 to n
390 if max < dhdp (j) then max = dhdp (j)
400 next j
495 rem array calculation dp0 (n)
510 for j = 0 to n
520 dp0 (j) = p0 (j) - lambda * dhdp (j) / abs (max)
530 next j
540 rem calculation of new control
545 p1 (0) = 1
550 for j = 1 to m
560 if dp0 (j) > p2 then p1 (j) = p2 else
if dp0 (j) < p1 then p1 (j) = p1 else p1 (j)
= dp0 (j)
570 next j
580 rem output results
584 print “k =”; k, “F =”; F, “max =”; max
586 for j = 0 to m step 2
587 print “p1 (“; j ;”) =”; p1 (j)
588 next j
589 for i = 1 to n
590 for j = 0 to m step 5
600 print “z (“; i ;”, ; j ;”) =”; z (i, j)
610 next j
620 next i
630 rem determination of the termination of the
iteration process

```

The calculations were performed for the following parameter values:  $T = 0.2, p_1 = 0.2, p_2 = 1$ . The function  $p_c^0(t) = 1 - 10t^2$  was taken for zero iteration. The segment  $0 \leq x \leq 1$  is divided into five parts with a step  $h = 0.2$ . The systems of equations (12) – (13) and (15) – (16) are integrated with a constant step  $t = 0.01$ , and the results are output with a step  $t = 0.05$ . Note that the integration of these systems by the Runge - Kutta method with automatic step selection is associated with some difficulties. Since the values of the functions  $z_i(t)$

and  $\psi_i(t), i=1,2,\dots,n$  will be calculated at different points, and when integrating system (12) – (13) simultaneously with system (15) – (16) from  $t = T$  to  $t = 0$  with a constant step, the counting process is often unstable, then the amount of computation increases. To check the optimality found by the control formulas (23) – (24), in the calculations as  $q^*(t)$  we took

$$\frac{\partial p^2(0,t)}{\partial x} \approx \frac{1}{h} [z_1^2(t) - (p_c^*(t))^2] \quad (25)$$

for a given control  $p_c^*(t) = 1 - 4t$ . The optimality of  $p_c^*(t)$  is obvious since the minimum value of the functional is zero. Note that the found control sequences  $p_c^k(t), k = 0, 1, \dots$  with the increasing number of iterations, as can be seen from the above graphs, in the time interval  $0 \leq t \leq T$  approach the given control  $p_c^*(t)$  and very precisely coincide with the control  $p_c^*(t)$ . The value of the functional at the 59th iteration turned out to be  $\cong 6.95854 \cdot 10^{-7}$ , and the maximum value of  $\partial H / \partial p_c$  turned out to be  $\cong 0.0531$ . With further iterations, the qualitative picture of the results remained practically unchanged.

Figure 1 shows the obtained minimizing control

sequences for some intermediate iterations, and Table 1 shows the convergence in the functional of the iterative process (23) – (24).

According to this table, graphs of changes in gas pressure in the reservoir are constructed at different instant of time. Figure 3 shows that the pressure value varies greatly in the area of the bottomhole formation zone, and outside this zone, the pressure graph is represented by an almost straight line. This is due to a violation of the linear law of filtration due to high gas filtration rates exactly in the bottomhole formation zone.

Figure 4 shows the dependence of the time variation of the bottomhole pressure at different distances from the well axis. Figure 4 shows that approximately from the moment of time  $t = 0.02$  bottomhole pressure changes almost in a straight line. This means that when solving the boundary value problem numerically, the time step can be significantly increased without reducing the accuracy of the calculation results.

Thus, by controlling the bottomhole pressure  $p_c(t)$  within certain limits, it is possible to maintain conditions in the region of the bottomhole zone that determine the technological mode of gas well operation.

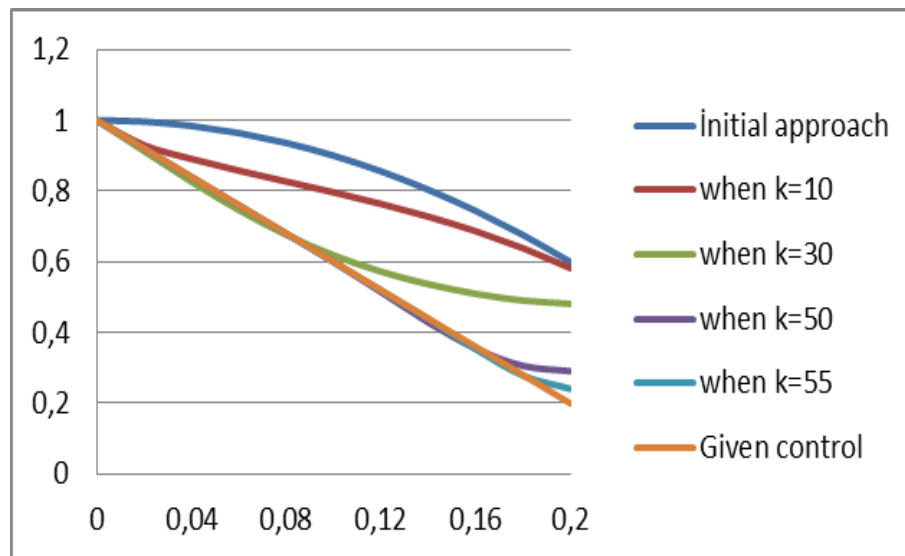

Fig. 1. Approximately optimal controls during iterations.

**Table 2. The calculation results corresponding to the bottomhole pressure  $p_c(t)$  found according to the scheme (23) – (24).**

$t$	$z_0$	$z_1$	$z_2$	$z_3$	$z_4$	$z_5$
0.00	1.0000	1.0000	1.0000	1.0000	1.0000	1.0000
0.02	0.9188	0.9901	1.0000	1.0000	1.0000	1.0000
0.04	0.8405	0.9590	0.9928	0.9993	1.0000	1.0000
0.06	0.7600	0.9209	0.9781	0.9954	0.9993	0.9993
0.08	0.6801	0.8799	0.9586	0.9879	0.9968	0.9968
0.10	0.6001	0.8380	0.9362	0.9773	0.9917	0.9917
0.12	0.5198	0.7961	0.9120	0.9641	0.9840	0.9840
0.14	0.4403	0.7550	0.8868	0.9489	0.9737	0.9737
0.16	0.3598	0.7154	0.8611	0.9320	0.9613	0.9613
0.18	0.2803	0.6778	0.8355	0.9138	0.9470	0.9470
0.20	0.2008	0.6425	0.8102	0.8948	0.9312	0.9312

```

k= 56          F = 1.346993E-05          max= .2163741
p1( 0 )= 1
p1( 4 )= .8399721
p1( 8 )= .6799241
p1( 12 )= .5199618
p1( 16 )= .3556883
p1( 20 )= .2308937

k= 57          F = 6.049348E-06          max= .1577634
p1( 0 )= 1
p1( 4 )= .8399748
p1( 8 )= .6799723
p1( 12 )= .519972
p1( 16 )= .3585097
p1( 20 )= .2208937

k= 58          F = 2.204288E-06          max= .1034098
p1( 0 )= 1
p1( 4 )= .8400139
p1( 8 )= .6799639
p1( 12 )= .5201467
p1( 16 )= .3605298
p1( 20 )= .2108937

k= 59          F = 6.95854E-07          max= 5.312822E-02
p1( 0 )= 1
p1( 4 )= .8405519
p1( 8 )= .6801361
p1( 12 )= .5198278
p1( 16 )= .3598418
p1( 20 )= .2008937

```

**Fig. 2. Fragment of the results on the iterative process' implementation (23)-(24).**

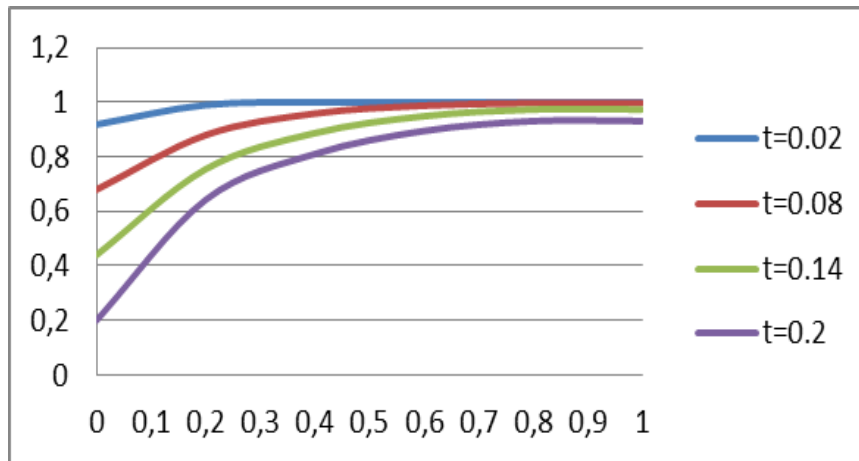

Fig. 3. The gas pressure distribution profiles at different instants of time corresponding to the pressure  $p_c(t)$  found according to scheme (23) – (24).

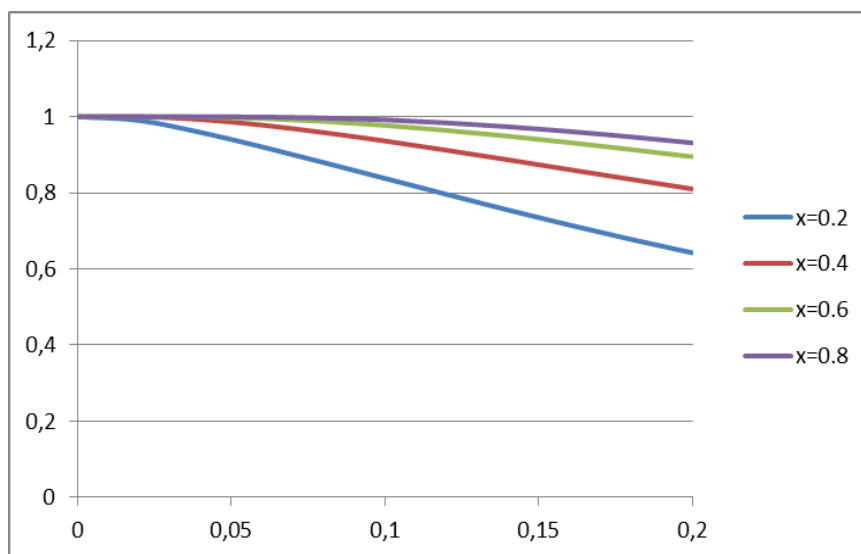

Fig. 4. Change in time of bottomhole gas pressure at different distances from the well axis.

## 6. DISCUSSION AND CONCLUSIONS

In the new economic conditions of fierce competition, the stable socio-economic development of states, their security and possible recipes for resolving conflicts depend on energy security. In the proposed approach to solving the problem, the regions of the Caucasus (Azerbaijan) and South Asia (Bangladesh) are of particular interest to the authors.

Despite the successes, currently, there are still not sufficiently convincing formulations of the problems on regulating the oil and gas fields' development, although these should be based on the methods of the optimal control theory. Undoubtedly, it could be affirmed that optimization methods have not found proper application when considering the prospects for developing a single field, a group of fields or the prospects for developing the oil and gas industry.

In the present paper, an analysis of the goals and criteria on the problem of gas flows' optimal control in

the framework of controlling the bottomhole pressure under certain conditions is performed.

The reasoning for choice of the technological mode of gas well operation is carried out. The formalization of the corresponding optimization problem is carried out, its reducibility to the problem of systems' optimal control is determined; the behavior of such systems can be described by a set of differential equations in partial and ordinary derivatives. An approach to its solution with the condition of the parameters' distribution is described.

The studies and analysis of the obtained numerical calculations allow us to draw the following conclusions:

1. Using the Pontryagin's maximum principle, which is a powerful mathematical apparatus, the study of optimal control problems allows us to determine the technological mode of gas well operation. The technological mode of wells operation depends on a number of different factors, such as the possibility of destruction in the bottomhole



formation zone, the presence of bottom water, the temperature effect on the productive formation and environment surrounding the wellbore, multilayer formation and heterogeneity of deposits. Taking into account all these factors allows us to talk about the fundamental principle of the maximum.

2. If the solution of the approximating system (12) – (13) with a fixed control  $p = p_c(t)$  converges to the solution of the original boundary value problem, then there is always convergence in the functional, and the approximately optimal control found in this way is minimizing. In this case, an approximate solution of the problem is understood as a permissible control in which the value of the minimized functional turns out to be arbitrarily close to the exact lower bound of this functional on the set of permissible controls.
3. The gradient projection method with a specially selected step, even despite the incorrectness of the control problem for systems with quadratic functional, does not lead to a tendency to “hopper agitation”, and in a short time gives a convergent minimizing sequence in the control space.
4. In this paper, for the problem of minimizing the functional, the convergence of the gradient projection method with a constructive choice of a step that does not require solving auxiliary minimization problems is established.
5. For the numerical solution of optimal control problems for nonlinear systems with distributed parameters, the use of the straight-line method is very effective, since it does not necessitate consideration of the conjugate boundary value problems for partial differential equations. When finding a solution to the optimal control problem for systems with distributed parameters, the nature of the convergence and the very fact of the convergence of the straight-lines’ method used in the work are presented.
6. The integration of the original equation system, the calculation of the functional’s value, the integration of the conjugate system, as well as the calculation of the new control are implemented by a computer program.

The results obtained determine the direction for further research, and the methods used may be useful for future research not only in the tasks of optimal control of gas wells, but also in other processes of designing the development of hydrocarbon deposits. The obtained data and conclusions can be included in studies on the development of optimal solutions for controlling gas wells.

## REFERENCES

- [1] Aidazade K.R. and A. G. Bagirov, 2006. Study of the problem of optimal placement of oil reservoir wells and control of their flow rates. *Automation and Telemechanics* 1: 52-62.
- [2] Boah A.E., Kondo K.S.O., and Borsah A.A., 2019. Critical evaluation of infill well placement and optimization of well spacing using the particle swarm algorithm. *Journal of Petroleum Exploration and Production Technology* 9: 3113–3133.
- [3] Egorov A.I. and L.N. Znamenskaya, 2005. On controllability of oscillations of a coupled objects’ system with distributed and concentrated parameters. *Journal of Computational Mathematics and Mathematical Physics* 45(10): 1766-1784.
- [4] Ghassemzadeh S. and P. Pourafshary, 2015. Development of an intelligent economic model to optimize the initiation time of gas lift operation. *Journal of Petroleum Exploration and Production Technology* 5: 315–320.
- [5] Hwang M., Seinfeld J.H., and Gavlas G.R., 1972. Optimal least-square filtering and interpolation in distributed parameter systems. *Journal of Mathematical Analysis and Applications* 39: 49-74.
- [6] Janiga D., Czarnota R. and Stopa J., 2019. Utilization of nature-inspired algorithms for gas condensate reservoir optimization. *Soft Comput.*, 23: 5619-5631.
- [7] Jun J., Kang J., and Jeong D., 2016. An efficient approach for optimizing full field development plan using Monte-Carlo simulation coupled with genetic algorithm and new variable setting method for well placement applied to gas condensate field in Vietnam. *Energy Exploration & Exploitation* 35(1): 75-102.
- [8] Kot P.A., 2010. On the methodology for choosing the rational option for developing a gas field. *Problems of Economics and Management of the Oil and Gas Complex* 1: 19-22.
- [9] Kuleshova N.S., 2017. Modern trends in energy cooperation in South Asia. *World politics* 1: 13-26. DOI: 10.7256/2409-8671.2017.1.22472 URL: [https://nbpublish.com/library\\_read\\_article.php?id=22472](https://nbpublish.com/library_read_article.php?id=22472).
- [10] Leibenzon L.S., 1953. Underground Hydrodynamics. Collection of works, Moscow: Publishing House of the Sciences Academy of USSR.
- [11] Leonchuk M.P., 1964. On the numerical solution of optimal processes with distributed parameters, *Journal of Computational Mathematics and Mathematical Physics* 4(6): 1112-1117.
- [12] Mamtiyev K.K., Hasanova Z.B., and Rustamova M.A., 2017. The solution to one problem of optimal management of depletion of the host bed. *Bulletin of the Azerbaijan State Economic University* 5: 117-126.
- [13] Mirzaei-Paiaman A. and S. Salavati, 2012. The application of artificial neural networks for the

- prediction of oil production flow rate. *Energy Sources Part A Recovery Utilization and Environmental Effects* 34(19).
- [14] Namdar H., 2019. Developing an improved approach to solving a new gas lift optimization problem. *Journal of Petroleum Exploration and Production Technology* 9: 2965–2978.
- [15] Pontryagin L., Boltyansky V.G., Gamkrelidze R.B., and Mishchenko E.F., 1976. *The Mathematical Theory of Optimal Processes*. Wiley Interscience, New York.
- [16] Saydelov A.R. and M.A. Asylov, 2017. Experience of using gas turbine plants for power generation. *Symbol of Science* 1. URL: <https://cyberleninka.ru/article/n/opyt-ispolzovaniya-gazoturbinyh-ustanovok-dlya-vyrabotki-elektroenergii>.
- [17] Shang J., Ji Z., and Qiu M., 2019. Multi-objective optimization of high-sulfur natural gas purification. *Petroleum Science* 16: 1430-1441.
- [18] Skiba A.K., 2009. The maximum principle in the problem of maximizing income for the gas-field model. *Bulletin of the Peoples' Friendship University of Russia. Series: Mathematics. Computer science. Physics* 1: 14-22.
- [19] Slabnov V.D., 2015. Methods of mathematical modelling and numerical solution of forecasting problems and optimal regulation of the oil recovery process (review). *Bulletin of Kazan Technological University C*: 198-209.
- [20] Soemardan S., Purwanto W.W., and Arsegianto, 2013. Production optimization for plan of gas field development using marginal cost analysis. *Makara Seri Teknologi* 17(2): 94-102.
- [21] Teymurov R.A., 2013. On the problem of controlling mobile sources for systems with distributed parameters. *Bulletin of Tomsk State University* 1(21): 24-33.
- [22] Tugov V.V., Tarasov V.N., and Fakhritdinov T. B., 2011. Optimal control of the oil mixture preparation process under acoustic exposure. *Bulletin of the Orenburg State University* 1(120): 209-213.
- [23] Vasiliev F.P., 2002. *Optimization Methods*. Moscow: Factorial.
- [24] Velez-Langs O., 2005. Genetic algorithms in oil industry: An overview. *Journal of Petroleum Science and Engineering* 47(1-2): 15-22.
- [25] Zakirov E.S., Mangazeev V.P., and Zakirov I.S., 2002. Regulation of the development of multi-layer deposits. *Geology, Geophysics and the Development of Oil and Gas Deposits* 5: 73-78.
- [26] Zakirov S.N. and B.B. Lapuk, 1974. *Design and development of gas fields*. Moscow: Nedra.
- [27] Zerafat M.M., Ayatollahi S., and Roosta A., 2009. Genetic algorithms and ant colony approach for gas-lift allocation optimization. *Journal of the Japan Petroleum Institute* 52(3): 102-107.





# Thermodynamic Analysis of Biomass Gasification for Energy Sustainability in Bangladesh and Major Crop Producing Asian Countries

[www.ericjournal.ait.ac.th](http://www.ericjournal.ait.ac.th)

Sampad Kumar Das\* and Prokash C. Roy\*<sup>1</sup>

**Abstract** – Biomass has an important role for energy sustainability issues in tropical countries. In this present study biomass gasification process has been studied using a stoichiometric equilibrium model of biomass gasifier. The gasification process has been considered as a combination of methanation reaction and water gas shift reaction. The reaction rate constants have been considered as an explicit function of gasification temperature. The model has been validated with available experimental results and used to study the effect of equivalence ratio and reaction temperature on the overall gasification process. Three different biomasses specifically rice straw, rice husk and animal manure waste have been considered. The equivalence ratio has been varied from 0.15 to 0.35 for all considered biomass feedstock. The gasification model has been examined for temperatures 1073K and 1173K for all combinations of biomass and equivalence ratio. The mole percentage of different gas specifically hydrogen, carbon monoxide, methane and carbon dioxide have been calculated as a function of the theoretical mole fraction of different gases and equivalence ratio for all the considered biomasses. The cold gas efficiency and lower heating value of the produced gas mixture have been estimated. Finally estimation of energy by biomass gasification has been examined for energy sustainability in major crop-producing Asian nations.

**Keywords** – Crop and animal manure waste, equivalence ratio, gasification, stoichiometric equilibrium, sustainability.

## 1. INTRODUCTION

In the present situation of global economic and environmental demand, it has been observed that the continuous increase in energy demand must be sustainable and compatible with the environmental standards of earth. Renewable and eco-friendly technology is required to reduce the pollution by conventional energy conversion technique. Biomass gasification has been observed as an admirable alternative in this regard. It has also been observed that renewable natural resources like crops, animal products and manure waste have not been utilized in its full capacity for past and present decades in the conventional techniques of energy production. It has been identified as per available data that countries in Asia are capable to recycle their yearly production of crops and animal manure into energy with a greater sustainable impact on their economy and environment. Crops and animal manure waste have been considered with great potential to solve the energy crisis and sustainability issues using gasification technology for a long period of time. The gasification temperature and airflow rate have been identified as major influential parameters for biomass gasification. The effect of these influential parameters on biomass gasification has been studied by several techniques in different literature [1]-[4]. The stoichiometric equilibrium method and minimization of

Gibb's free energy method have been identified as the most effective and efficient technique [5]-[9]. In this present study thermodynamic analysis of biomass gasification process has been carried out using a stoichiometric equilibrium method to predict the performance of the biomass gasifier and to study the role of sustainable energy generation for Bangladesh and other major crop-producing nations in Asia.

## 2. OBJECTIVE AND DESCRIPTION OF STUDY

In the present study biomass gasification process has been studied using a stoichiometric equilibrium model. The model has been developed to study the effect of equivalence ratio and reaction temperature on the overall gasification process. Three different biomasses such as rice straw, rice husk and animal manure waste have been considered. The proximate and ultimate analysis data of these biomasses on a dry basis have been taken from available literature of Tillman *et al.* [10] and Kitani *et al.* [11], are tabulated in Tables 1 and 2.

**Table 1. Ultimate analysis of biomass wt% on dry basis.**

Biomass	C	H	O	N	Ash	HHV (MJ/Kg)
Rice Straw	39.2	5.1	35.8	0.6	19.3	15.21
Rice Husk	38.5	5.7	39.8	0.5	15.5	15.38
AMW	42.7	5.5	31.3	2.4	18.1	17.17

**Table 2. Moisture content of biomass (wt % of dry biomass).**

Biomass	Rice Straw	Rice Husk	AMW
MC	8	10	22

\*Department of Mechanical Engineering, Jadavpur University, Jadavpur University, 188 Raja S.C. Mullik Road, Kolkata 700032, India.

<sup>1</sup>Corresponding author;

Tel: + 91 33 24146890 ext 2668, Fax: + 91 33 24146890.

E-mail: [prokash.roy@gmail.com](mailto:prokash.roy@gmail.com)



In the present work, the gasification process has been considered as a combination of methanation reaction and water gas shift reaction. The mass balance of different constituent elements in reactant has been considered with the reaction rate constant to evaluate different gas yields due to gasification. The reaction kinetics has been studied by different literature [12]-[21]. It has been found that the reaction rate constants are the function of Gibb's free energy and reaction temperature. It has also been observed that Gibb's free energy depends on the enthalpy of reactants and products of the reaction at reaction temperature. Therefore, it has been identified that without the use of Gibb's free energy calculation by conventional enthalpy method (Gibb's free energy in terms of enthalpy of reactant and product); it can also be calculated from the temperature of the reaction. In the present model, a simplified reaction rate constant formula has been used to predict product gas composition such as hydrogen, carbon monoxide, methane, carbon dioxide and water vapour. It has been observed that the reaction rate constant has been multiplied by a certain factor to fit the result with experimental data to compensate for the simplification of real and complex gasification processes by a simplified mathematical model. It has also been identified that the process of selection of multiplication factor to the reaction rate constant is not methodical and comprises a trial and error procedure. To avoid the ambiguity of trial and error for the multiplication factor, a thorough study of the gasification process and its influential parameter has been carried out. It has been identified that the different gas yield in the gasification process depends on the equivalence ratio, gasification temperature and steam flow rate. The mole percentages of different gases have been calculated as a function of theoretical mole fraction of corresponding gas and equivalence ratio. The cold gas efficiency (CGE) and lower heating value (LHV) of the produced gas have been calculated from the mole percentage of different gases. Outcome of the estimated performance using the developed model has been used to examine energy sustainability in terms of estimated energy by biomass for countries like Bangladesh, India, China, Thailand, Indonesia, Myanmar, Vietnam and the Philippines. Therefore estimation of their energy by biomass has been studied from available data. It has been found that these countries are the main producer of the crop in Asia according to the Food and Agriculture Organization (FAO) of the United Nations. The data used to get their crop production per year has been taken from FAO statistics about crop production. The data for paddy production per year has been taken from the average of yearly production from 1994 to 2018. On the other hand, animal manure waste has been considered as cattle manure only because it contributes nearly 90% of total animal manure waste production per year. The paddy production rate and animal manure (cattle manure) in million tonnes (Mt) per year have been given in Table 3.

Nguyen Van Hung *et al.* [22] reported straw to grain ratio (SGR) of rice from yearly paddy yield as 4.3:1 by and the same value also was reported by Salman Zafar [23]. On the other hand straw to grain ratio for rice has been reported as 3:1 by R. B. Singh *et al.* [24]. ESCAP (Economic and Social Commission for Asia and the Pacific) and CSAM (Centre for Sustainable Agricultural Mechanization) have reported straw to grain ratio as 1.28:1 in the United Nations report [25].

**Table 3. Paddy and AMW production per year for countries.**

Country	Paddy(Mt/year) 1994-2018 average	AMW (Mt/year) 2017 survey
Bangladesh	41.7	0.8
China	193.1	5.6
India	140.9	7.03
Indonesia	60.4	1.1
Myanmar	24.5	1.18
Philippines	14.9	0.2
Thailand	29.4	0.31
Viet Nam	36.3	0.37

The IRRI (International Rice Research Institute), has reported the grain to husk ratio as 3.5:1 in their Rice Knowledge Bank [26]-[27]. FAO (Food and Agriculture Organization) [28] of the United Nations reported the grain to rice husk ratio (GHR) as 7:3 in their article of grain losses in rice processing. Therefore in the present study for calculation of rice straw and rice husk, the straw to grain ratio and grain to husk ratio have been considered as 3:1 and 4:3, respectively, considering all the losses during rice milling and paddy harvesting process. To study the regional effect on the straw to grain ratio and grain to husk ratio, data of total paddy, milled rice, rice straw and rice husk production have been considered and shown in Table 4.

**Table 4. Paddy, milled rice, rice Straw and rice husk production in million tonnes (Mt) per year for different countries (IRRI statistics 2014).**

Country	Paddy	Milled rice	Rice Straw	Rice Husk
China	206.5	144.56	264.32	61.94
India	157.2	105.48	201.216	51.72
Indonesia	70.84	35.56	90.6752	35.28
Bangladesh	52.32	34.5	66.9696	17.82
Vietnam	44.97	28.16	57.5616	16.81
Thailand	32.62	18.75	41.7536	13.87
Myanmar	26.42	12.6	33.8176	13.82
Philippines	18.96	11.91	24.2688	7.05

### 3. METHODOLOGY

Biomass gasification is a very complex chemical process and depends on several reaction kinetics and different influential parameters like temperature, pressure, oxygen

content, carbon content, steam flow rate, the ash content of biomass and moisture content of biomass[29]-[32]. It has also been identified that the gasification process can be simulated by addressing the important chemical kinetics of the process on an overall basis. It has been observed that the most popular methods to address the kinetics and the different conservation principles are stoichiometric equilibrium method and minimization of the Gibbs free energy method. In the present work, the stoichiometric equilibrium method has been used.

### 3.1 Development of Mathematical Model

To analyse the main gasification process the gasification equation has been considered as Equation 1;

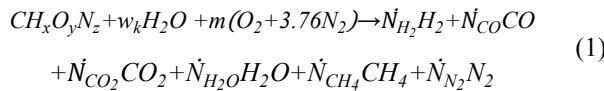

Where  $w_k, x, y, z, m$  have been calculated from biomass ultimate analysis and from the Equations 2 and 3;

$$w_k = \frac{M_B \times MC}{(1 - MC) \times 18} \quad (2)$$

$$m = \lambda(1 + 0.25x - 0.5y) \quad (3)$$

Here the values of  $\dot{N}_{H_2}, \dot{N}_{CO}, \dot{N}_{CO_2}, \dot{N}_{H_2O}, \dot{N}_{CH_4}, \dot{N}_{N_2}$  have been considered as the unknown parameter.

These values of unknown parameters have been calculated to get the composition of producer gas yield.

For this purpose, the equations of mass balance for carbon, hydrogen, oxygen and nitrogen have been used along with methanation reaction and water-gas shift reaction, which are given in Equations 4 to 11;

$$\dot{N}_{CO} + \dot{N}_{CO_2} + \dot{N}_{CH_4} = 1 \quad (4)$$

$$2\dot{N}_{H_2} + 2\dot{N}_{H_2O} + 4\dot{N}_{CH_4} = x + 2w_k \quad (5)$$

$$\dot{N}_{CO} + 2\dot{N}_{CO_2} + \dot{N}_{H_2O} = y + w_k + 2m \quad (6)$$

$$2\dot{N}_{N_2} = z + 7.52m \quad (7)$$

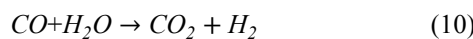
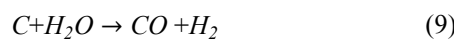

Here Equations 8 and 9 have been combined together to form Equation 10 (water-gas shift reaction).

### 3.2 Analysis of Reaction Kinetics

The main reactions in gasification process have been assumed as combination of water-gas shift reaction and methanation reaction represented in Equations 10 and 11. The reaction rate constants of methanation reaction

and water-gas shift reaction have been related to the unknown parameters by Equations 12 and 13;

$$K_{mn} = \frac{\dot{N}_{CH_4}}{(\dot{N}_{H_2})^2} \quad (12)$$

$$K_{wgs} = \frac{\dot{N}_{H_2} \times \dot{N}_{CO_2}}{\dot{N}_{CO} \times \dot{N}_{H_2O}} \quad (13)$$

Through analysis of chemical kinetics, it has been observed that the equilibrium rate constants ( $K_{mn}$  and  $K_{wgs}$ ) are functions of reaction temperature  $T$  and Gibbs free energy ( $\Delta g_{mn}^0, \Delta g_{wgs}^0$ ) of the corresponding reactions. It has also been observed that the Gibbs free energy is a function of reaction temperature. Therefore the reaction rate constants have been calculated as a function of gasification temperature. The functional formula of reaction rate constants (Equations 14 to 17) has been adopted from the simplified reaction rate constant formula of Zainal *et al.* [33].

$$K_{mn} = \exp\left(-\frac{\Delta g_{mn}^0}{RT}\right) \quad (14)$$

$$K_{wgs} = \exp\left(-\frac{\Delta g_{wgs}^0}{RT}\right) \quad (15)$$

$$K_{mn} = \exp\left(\frac{5878}{T} + 1.86 \ln T - 0.27 \times 10^{-3}T - \frac{58200}{T^2} - 18\right) \quad (16)$$

$$K_{wgs} = \exp\left(\frac{7082.842}{T} - 6.567 \ln T + \frac{7.467 \times 10^{-3}}{2}T - \frac{2.167 \times 10^{-6}}{6}T^2 + \frac{0.702 \times 10^{-5}}{2T^2} + 32.541\right) \quad (17)$$

### 3.3 Numerical Method Adopted

The six Equations 4, 5, 6, 7, 12 and 13 have been solved simultaneously to get the Equation 18;

$$A\dot{N}_{H_2}^4 + B\dot{N}_{H_2}^3 + C\dot{N}_{H_2}^2 + D\dot{N}_{H_2} + E = 0 \quad (18)$$

The developed equation (Equation 18) has been found as a fourth degree polynomial of mole fraction of hydrogen. The coefficients of this polynomial have been calculated from Equations 19 to 23;

$$A = 5K_{mn}^2 K_{wgs} \quad (19)$$

$$B = 6K_{mn} K_{wgs} - 6K_{mn} \quad (20)$$

$$C = K_{mn} - 2 + K_{mn} K_{wgs} (2C_2 - 6C_1 - 4) \quad (21)$$

$$D = 4 + 2C_1 - 4C_2 + K_{wgs} (2C_2 - 2C_1 - 4) \quad (22)$$

$$E = K_{wgs}(C_1^2 - 2C_1C_2 + 4C_1) \quad (23)$$

The values of  $K_{mn}$ ,  $K_{wgs}$  have been calculated from Equations 16 and 17 for different temperatures and the values of  $C_1$ ,  $C_2$  have been calculated from Equations 24 and 25;

$$C_1 = x + 2w_k \quad (24)$$

$$C_2 = y + w_k + 2m \quad (25)$$

After getting all the coefficients of Equation 18 it has been solved by the general solution of fourth degree polynomial. With the use of general solution for fourth degree polynomial, the value of mole fraction for hydrogen (the roots of Equation 18) has been calculated from Equations 26 to 33;

$$[\dot{N}_{H_2}]_{1,2} = -\frac{B}{4A} - S \pm \frac{1}{2} \sqrt{-4S^2 - 2P + \frac{Q}{S}} \quad (26)$$

$$[\dot{N}_{H_2}]_{3,4} = -\frac{B}{4A} + S \pm \frac{1}{2} \sqrt{-4S^2 - 2P - \frac{Q}{S}} \quad (27)$$

$$P = \frac{8AC - 3B^2}{8A^2} \quad (28)$$

$$Q = \frac{B^3 - 4ABC + 8A^2D}{8A^3} \quad (29)$$

$$S = \frac{1}{2} \sqrt{-\frac{2}{3}P + \frac{1}{3A} \left( W + \frac{U}{W} \right)} \quad (30)$$

$$W = \sqrt[3]{\frac{V + \sqrt{V^2 - 4U^3}}{2}} \quad (31)$$

$$U = C^2 - 3BD + 12AE \quad (32)$$

$$V = 2C^3 - 9BCD + 27B^2E + 27AD^2 - 72ACE \quad (33)$$

Out of these four different values of mole fraction for hydrogen; the real and mass balance compatible solution has been considered. After getting the values of mole fraction for hydrogen the mole fractions for  $CH_4$ ,  $CO$ ,  $CO_2$  and  $H_2O$  have been calculated from Equations 34 to 38;

$$[\dot{N}_{H_2}]_{th} = \dot{N}_{H_2} \quad (34)$$

$$[\dot{N}_{CH_4}]_{th} = K_{mn}\dot{N}_{H_2}^2 \quad (35)$$

$$[\dot{N}_{CO}]_{th} = \frac{4 - 2C_2 + C_1 - \dot{N}_{H_2} - 5K_{mn}\dot{N}_{H_2}^2}{2} \quad (36)$$

$$[\dot{N}_{CO_2}]_{th} = \frac{2C_2 - 2 - C_1 + \dot{N}_{H_2} + 3K_{mn}\dot{N}_{H_2}^2}{2} \quad (37)$$

$$[\dot{N}_{H_2O}]_{th} = \frac{C_1 - \dot{N}_{H_2} - K_{mn}\dot{N}_{H_2}^2}{2} \quad (38)$$

After all the calculations, it has been identified that the mole fractions of different constituent gases are multiple of their corresponding experimental values, by some factor. It has also been examined that the trend of mole fraction of different gases with respect to the equivalence ratio remains same as that of the experimental result. Therefore, the actual values of different gas yields have been calculated as fraction of theoretical mole fraction of different gas yields. Hence the actual mole fractions of  $H_2$ ,  $CH_4$ ,  $CO$  and  $CO_2$  have been calculated from Equations 39 to 46;

$$[\dot{N}_{H_2}]_{act} = \frac{[\dot{N}_{H_2}]_{th}}{F_{H_2}} \quad (39)$$

$$[\dot{N}_{CH_4}]_{act} = \frac{[\dot{N}_{CH_4}]_{th}}{F_{CH_4}} \quad (40)$$

$$[\dot{N}_{CO}]_{act} = \frac{[\dot{N}_{CO}]_{th}}{F_{CO}} \quad (41)$$

$$[\dot{N}_{CO_2}]_{act} = \frac{[\dot{N}_{CO_2}]_{th}}{F_{CO_2}} \quad (42)$$

$$F_{H_2} = -200\lambda^4 + 1933\lambda^3 - 72\lambda^2 + 11\lambda + 1.9 \quad (43)$$

$$F_{CH_4} = 1791\lambda^4 - 1632\lambda^3 + 501\lambda^2 - 57.4\lambda + 6.2 \quad (44)$$

$$F_{CO} = 1167\lambda^4 - 1467\lambda^3 + 636\lambda^2 - 105\lambda + 7.6 \quad (45)$$

$$F_{CO_2} = 0.1 \quad (46)$$

With the calculated values of mole fractions of all combustible gases ( $H_2$ ,  $CO$  and  $CH_4$ ) the  $LHV_g$  (lower heating value) of the produced gas has been calculated from Equation 47;

$$LHV_g = 10.78 \times \%H_2 + 12.63 \times \%CO + 35.88 \times \%CH_4 \quad (47)$$

[MJ]/Nm<sup>3</sup>]

Next to this the  $LHV_B$  (lower heating value of biomass) has been calculated from ultimate analysis of biomass and Equation 48;

$$LHV_B = HHV_B - h_b \left( \frac{9H + MC}{100} \right) \quad (48)$$

With the values of  $LHV_B$  and  $LHV_g$  the cold gas efficiency of gasification and estimated energy [34] with respect to the yearly biomass (rice straw, rice husk and AMW) production has been calculated from Equations 49 to 53 with mechanical and turbine efficiency 0.806 [35];

$$\eta_{CGE} = \frac{M_g \times LHV_g}{M_B \times LHV_B} \quad (49)$$

$$E_{Rice\ Straw} = \eta_{MT} \eta_{CGE} (0.28 \times P_{Straw} \times LHV_{Straw}) \quad (50)$$

$$E_{Rice\ Husk} = \eta_{MT} \eta_{CGE} (0.28 \times P_{Husk} \times LHV_{Husk}) \quad (51)$$

$$E_{AMW} = \eta_{MT} \eta_{CGE} (0.28 \times P_{AMW} \times LHV_{AMW}) \quad (52)$$

$$E_{Estimated} = E_{Rice\ Straw} + E_{Rice\ Husk} + E_{AMW} \quad (53)$$

#### 4. MODEL VALIDATION

To ensure the accuracy of the present model, it has been validated with the experimental results of Sittisun *et al.* [36]. For validation, the mole fractions of hydrogen, methane, carbon monoxide with respect to equivalence ratio have been compared between the experimental results and results obtained from the present model. The present study has been carried out for corn-cob biomass and the gasification temperature as 1073K. The moisture content for corn-cob has been considered as zero and the ultimate analysis data of Corn-Cob have been taken from the original reference shown in Table 5.

The mole fractions of different gas yield (hydrogen, methane, carbon monoxide) with respect to different equivalence ratio have been given in Figures 1 through 3. Result of lower heating value with respect to different equivalence ratio has been given in Figure 4. After the calculations of mole fractions of different gases the lower heating value ( $LHV$ ) of the produced gas has been calculated with respect to different equivalence ratio and compared with the experimental results. From the obtained results it has been identified that the mole fractions of different constituent gases are well validated with corresponding experimental values. It has also been observed that the trend of mole fraction of different gas with respect to the equivalence ratio remains same as that of the experimental result. The fluctuations have been identified and found very small with respect to the different equivalence ratio of gasification process.

**Table 5. Ultimate analysis of corn-cob wt% on dry basis [36].**

Biomass	C	H	O	N	HHV(MJ/Kg)
Corn-Cob	45.5	6.2	47	1.3	18.7

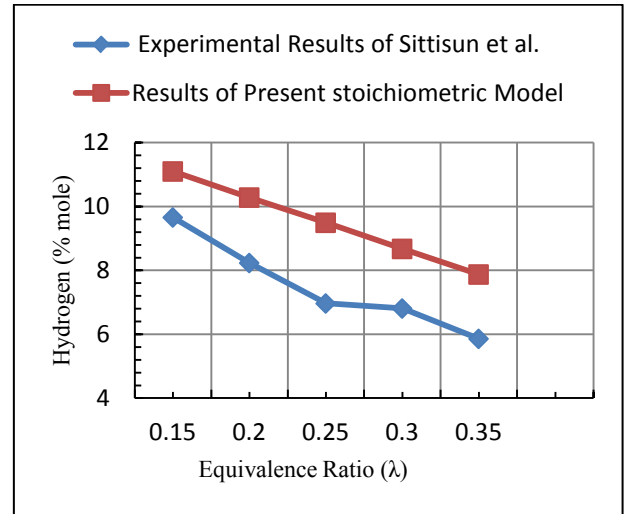

**Fig. 1. Hydrogen yield with respect to equivalence ratio.**

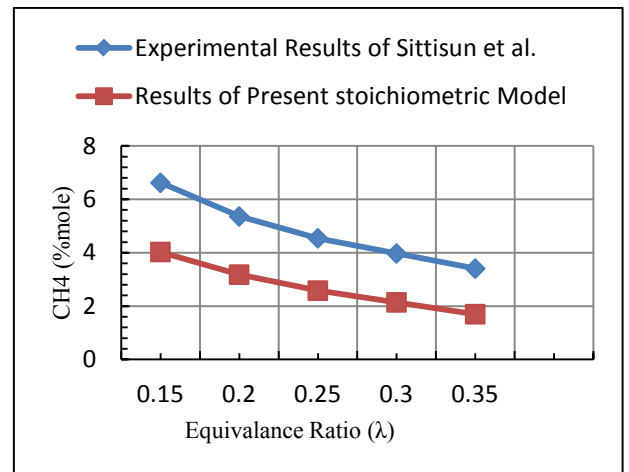

**Fig. 2. CH4 yield with respect to equivalence ratio.**

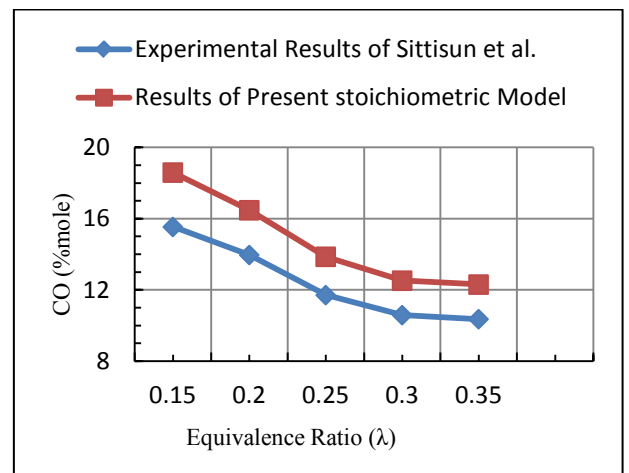

**Fig. 3. CO yield with respect to equivalence ratio.**



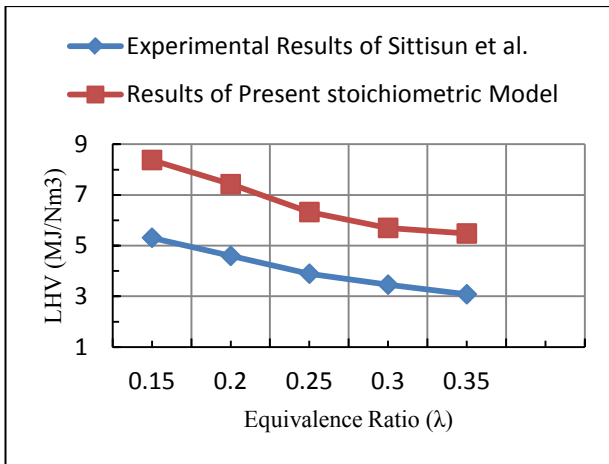

Fig. 4. Lower heating value (LHV) with respect to equivalence ratio.

To understand the exact deviation from experimental result with respect to different equivalence ratio, the root mean square error (RSME) has been calculated for all the produced gases namely hydrogen, methane and carbon monoxide. The calculated RSME for hydrogen gas yield with respect to the corresponding experimental result has been found to be 2.01. In case of methane gas yield, the RSME has been obtained as 2.08 with respect to the corresponding experimental result but for carbon monoxide the RSME has been identified as 2.36 with respect to the corresponding experimental result. In the calculations of lower heating value of produced gas with respect to different equivalence ratio, the RSME has been identified as 2.61 with respect to the corresponding experimental result.

Therefore present model with new kind of nonlinear stoichiometric coefficient for reaction rate constant, with no propagation of error to the next level of calculation has been identified as a well calibrated model.

## 5. RESULTS AND DISCUSSION

Gasification results have been analyzed with respect to equivalence ratio and gasification temperature for three different biomasses namely rice straw, rice husk and animal manure waste (AMW) separately. The results of different gas yield namely hydrogen, methane, carbon dioxide and carbon monoxide have been represented for gasification temperatures 1073K and 1173K along with the variation of equivalence ratio. Lower heating value and cold gas efficiency have also been represented for three different biomasses with the variation of equivalence ratio and temperature. The estimated energy has been represented for top eight crop producing countries of Asia. All the results have been given in the Figures 5 to 22.

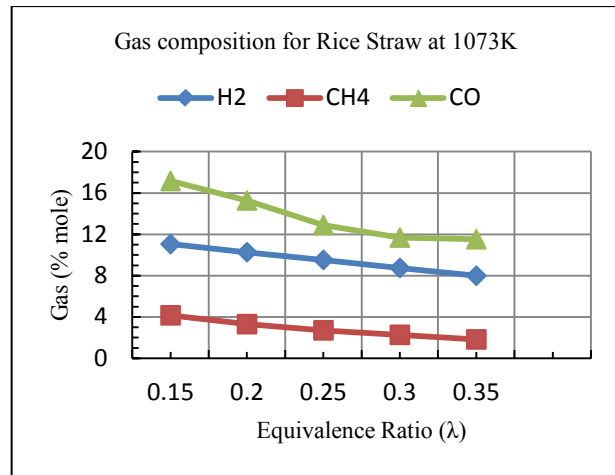

Fig. 5. Composition of different gas yield for rice straw at 1073K with respect to equivalence ratio.

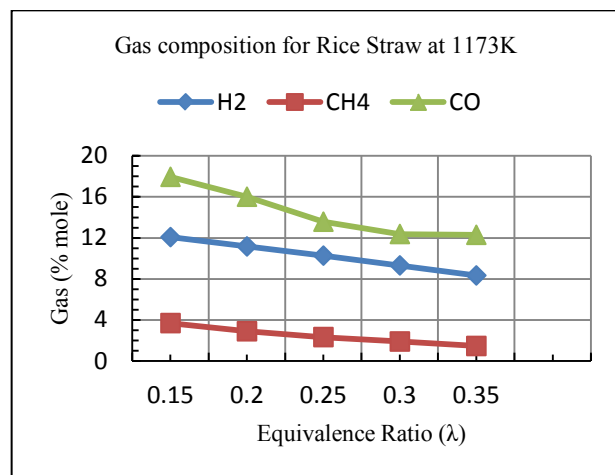

Fig. 6. Composition of different gas yield for rice straw at 1173K with respect to equivalence ratio.

### 5.1 Gasification Results for Rice Straw

In Figure 5 in case of rice straw at 1073K, hydrogen production has been observed to vary from 11 percent to 7.98 percent of produced gas based on mole percent. On the other hand, mole fractions of methane and carbon monoxide have been observed to vary from 4.2 to 1.8 percent and 17.14 to 11.52 percent respectively with the increase of equivalence ratio from 0.15 to 0.35. Similarly at 1173K with rice straw, the mole fraction of hydrogen and methane have been observed to vary from 12.07 to 8.33 and 3.69 to 1.46 percent with the increase of equivalence ratio from 0.15 to 0.35 shown in Figure 6. The mole fraction of carbon monoxide production has been observed to vary from 17.94 to 12.29 percent for variation of equivalence ratio from 0.15 to 0.35 at 1173K shown in Figure 7.

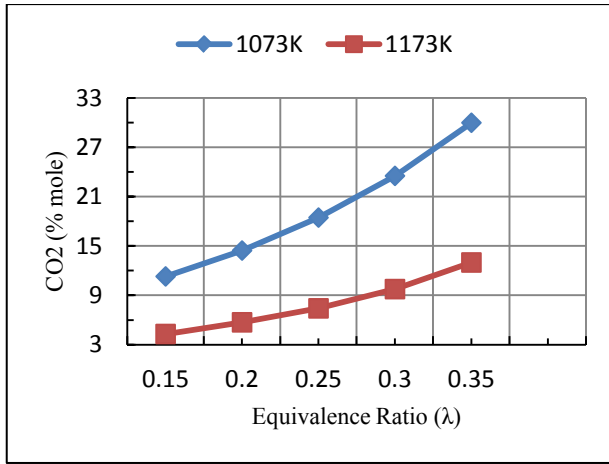

Fig. 7. Mole percentage of carbon dioxide yield for rice straw at 1073K and 1173K with respect to equivalence ratio.

5.2 Gasification Results for Rice Husk

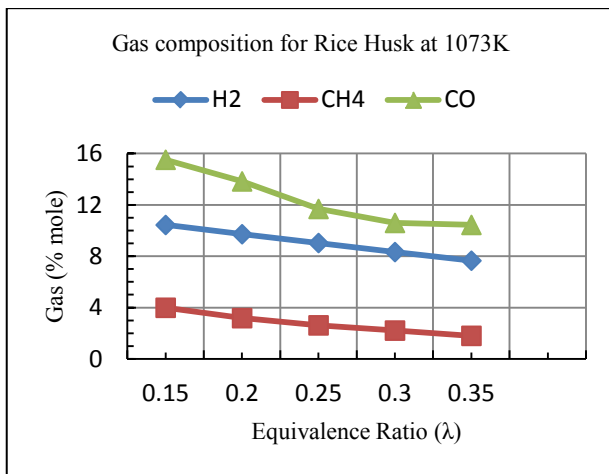

Fig. 8. Composition of different gas yield for rice husk at 1073K with respect to equivalence ratio.

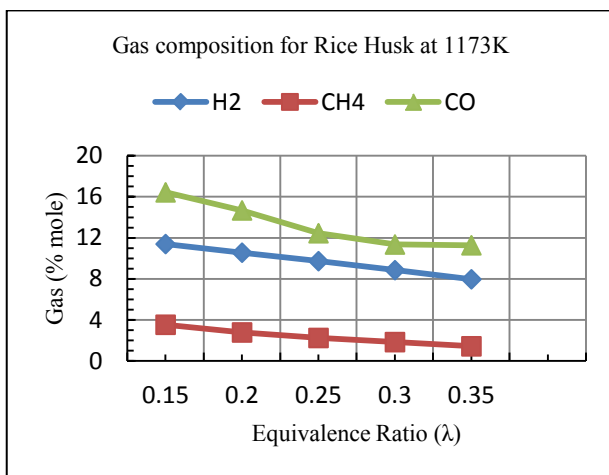

Fig. 9. Composition of different gas yield for rice husk at 1173K with respect to equivalence ratio.

Hydrogen production has been observed to vary

from 10.44 percent to 7.65 percent of produced gas based on mole percent for increase of equivalence ratio from 0.15 to 0.35 for rice husk at 1073K shown in Figure 8. Whereas mole fraction of methane and carbon monoxide have been identified to vary from 3.98 to 1.8 and 15.52 to 10.44 percent, respectively.

At 1173K the mole fraction of hydrogen and methane have been observed to vary from 11.40 to 7.96 and 3.53 to 1.43 percent with the increase of equivalence ratio from 0.15 to 0.35 for gasification with rice husk shown in Figure 9. At 1173K, the mole fraction of carbon monoxide production has been observed to vary from 16.44 to 11.28 percent for variation of equivalence ratio from 0.15 to 0.35, depicted in Figure 10.

With increase in equivalence ratio, it has been observed from Figures 8 to 10 that the decrease in combustible gas yield for rice husk is almost similar in trends as that of rice straw. But the mole fractions are more for hydrogen and carbon monoxide.

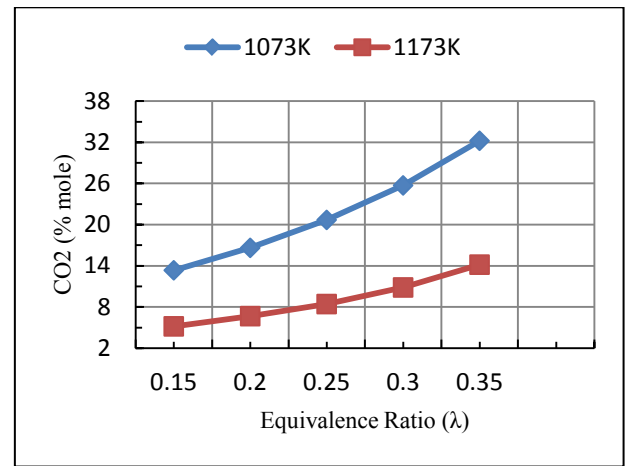

Fig. 10. Mole percentage of carbon dioxide yield for rice Straw at 1073K and 1173K with respect to equivalence ratio.

5.3 Gasification Results for AMW (Animal Manure Waste)

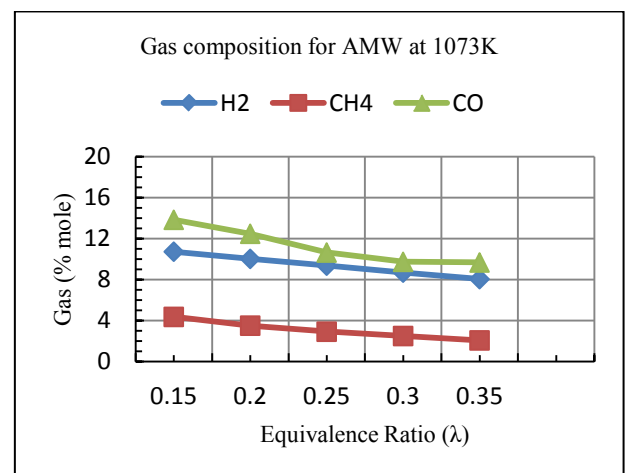

Fig. 11. Composition of different gas yield for animal manure waste at 1073K with respect to equivalence ratio.

Figure 11 shows the results of different gas composition using animal manure waste at 1073K. Hydrogen production has been observed to vary from 10.74 to 8.05 percent of produced gas based on mole percent. Whereas with the increase of equivalence ratio from 0.15 to 0.35 mole fraction of methane and carbon monoxide have been examined to vary from 4.36 to 2.07 percent and 13.85 to 9.68 percent, respectively. For gasification at 1173K with the use of animal manure waste, the mole fraction of hydrogen and methane have been identified to vary from 11.76 to 8.49 and 3.89 to 1.69 percent with the increase of equivalence ratio from 0.15 to 0.35 shown in Figure 12 and mole fraction of carbon monoxide production has been noticed to vary from 14.74 to 10.46 percent for the same variation in equivalence ratio shown in Figure 13.

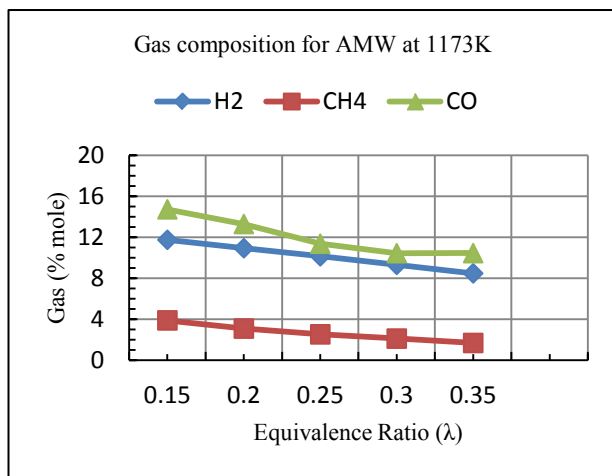

Fig. 12. Composition of different gas yield for animal manure waste at 1173K with respect to equivalence ratio.

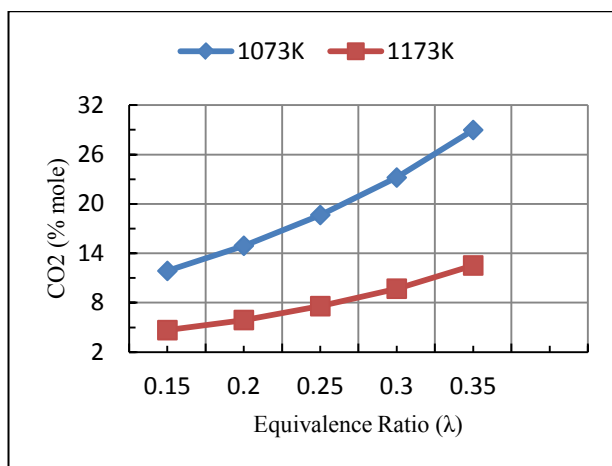

Fig. 13. Mole percentage of carbon dioxide yield for animal manure waste at 1073K and 1173K with respect to equivalence ratio.

#### 5.4 Results for LHV and CGE Calculations

According to the obtained results of mole fractions of hydrogen, methane and carbon monoxide the lower heating value of producer gas has the same decreasing

trend with respect to the equivalence ratio. From the results presented in Figures 14 to 17 it has been observed that the cold gas efficiency is highest for rice straw and lowest for rice husk at almost all equivalence ratio. The lower heating value (LHV) for producer gas has been found with a decreasing trend with respect to the equivalence ratio for all the biomasses.

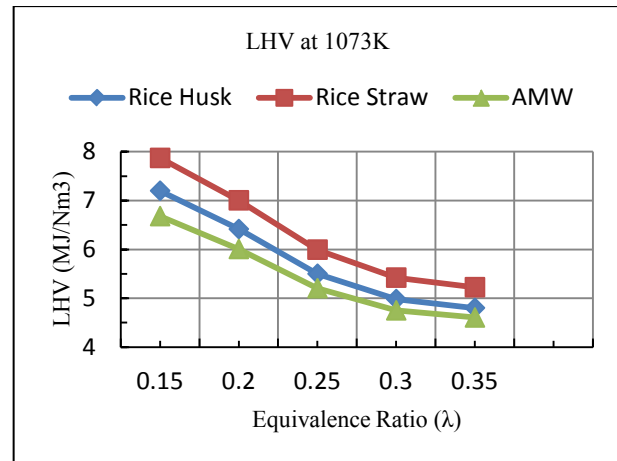

Fig. 14. Lower heating value (LHV) with respect to equivalence ratio at 1073K.

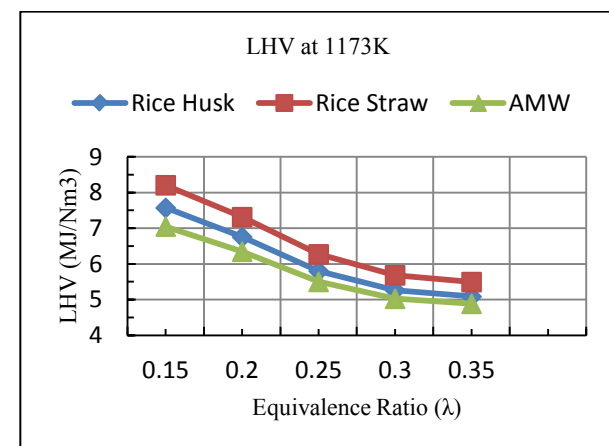

Fig. 15. Lower heating value (LHV) with respect to equivalence ratio at 1173K.

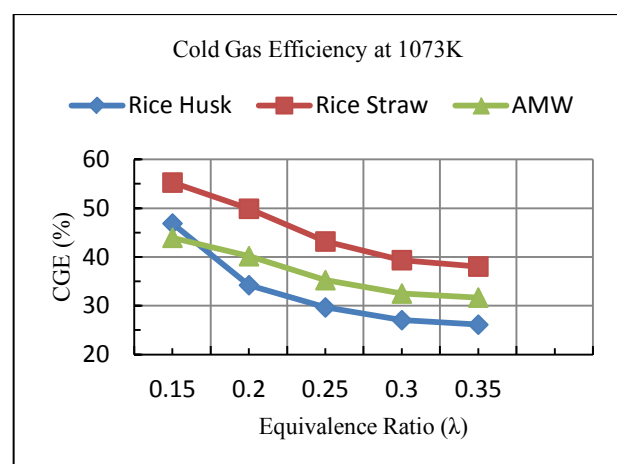

Fig. 16. Cold gas efficiency (CGE) with respect to equivalence ratio at 1073K.

On the other hand the cold gas efficiency has been observed with a similar decreasing trend with respect to the equivalence ratio for all the biomasses namely rice straw, rice husk and AMW at temperatures 1073K and 1173K. The value of lower heating value of producer gas has been examined to vary from 4.5 to 8.5 MJ/Nm<sup>3</sup> whereas the value of cold gas efficiency has been observed to vary from 20 to 70 percent.

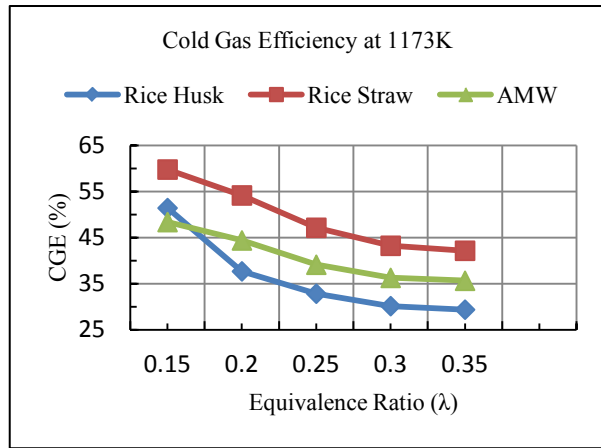

Fig. 17. Cold gas efficiency (CGE) with respect to equivalence ratio at 1173K

### 5.5 Results for Estimated Energy Capacity

With the results of mole fraction, lower heating value, and cold gas efficiency for rice straw, rice husk and animal manure waste, the estimated energy for Bangladesh and top eight crop producing countries in Asia are represented the Figures 18 through 22;

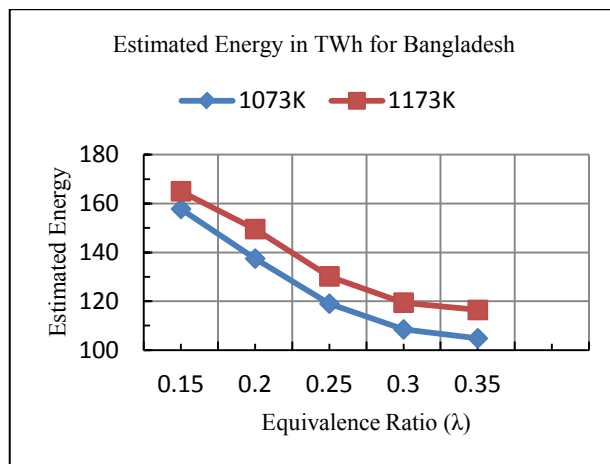

Fig. 18. Estimated energy with respect to equivalence ratio for Bangladesh.

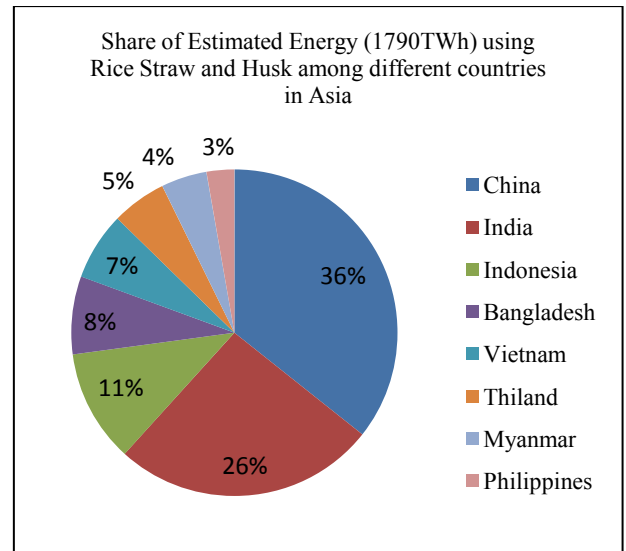

Fig. 19. Share of estimated energy (1790TWh) using rice straw and husk among different countries in Asia.

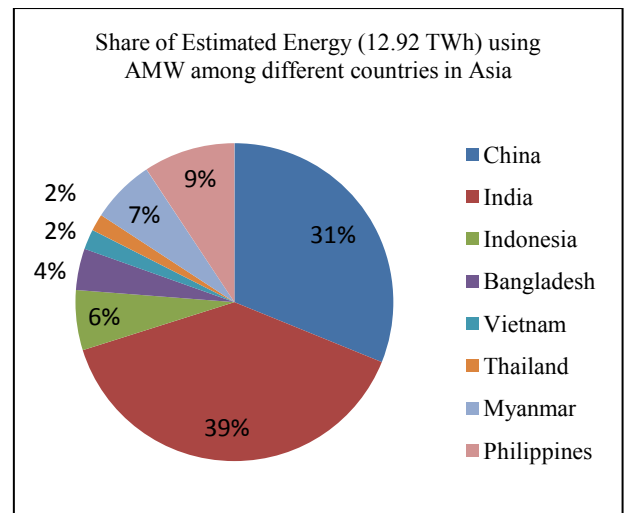

Fig. 20. Share of estimated energy (12.92 TWh) using AMW among different countries in Asia.

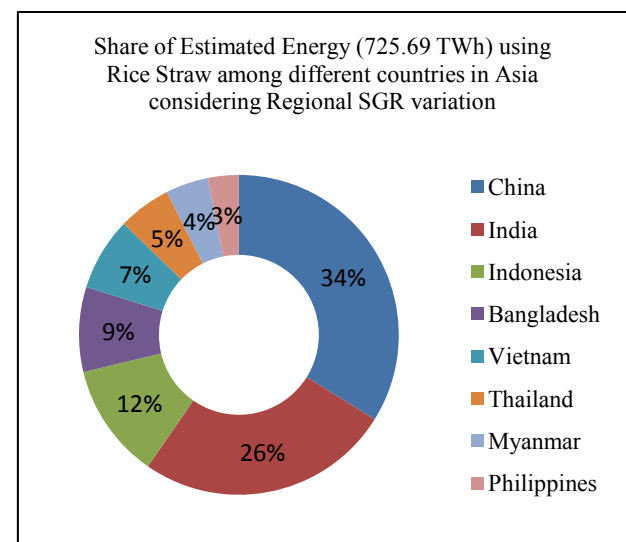

Fig. 21. Share of estimated energy (725.69 TWh) using rice straw among different countries in Asia.



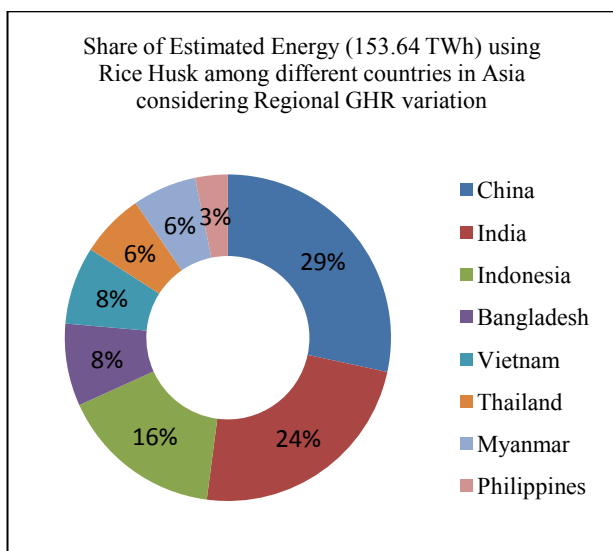

Fig. 22. Share of estimated energy (153.64 TWh) using rice husk among different countries in Asia.

Estimated energy has been observed to vary from 157.78 to 104.83 TWh and from 165 to 116.42 TWh for temperatures 1073K and 1173K, respectively for Bangladesh. With respect to rice straw and rice husk, China and India have been observed to contribute 62 percent of total yearly estimated energy among these eight countries. Bangladesh, Indonesia and Vietnam have been observed with capacity 8, 11 and 7 percent respectively.

For animal manure waste, the capacity of China and India has been observed to be 70 percent of total yearly estimated energy among these eight countries. Whereas the Philippines and Myanmar has been observed to share 9 percent and 7 percent, respectively.

## 6. CONCLUSION

Present study shows that the cold gas efficiency is more for rice straw and animal manure waste for all equivalence ratios and temperatures. The amount of hydrogen, methane and carbon monoxide is more with the rise in temperature. It has also been concluded that the present model have the potential to estimate the energy of different biomasses for different countries with different qualities of paddy yield. It has been realized that the model has successfully calculated the producer gas yield for variation of equivalence ratio and temperature. The estimated energy has been identified to satisfy considerable amount of energy demand in Bangladesh (nearly 165 TWh). It has been inferred that Bangladesh and Indonesia has a great potential of development in the renewable energy sector using biomass specially rice straw and rice husk nearly 7-8 percent of total. On the other hand, it has been derived that in terms of estimated energy from animal manure waste, the Philippines, Myanmar and Indonesia has great opportunity after China and India. On an overall perspective it has been concluded that the developed

gasification model is very useful tool to predict the producer gas yield with a good accuracy and the Asian crop producing countries have a great potential to manage the sustainability crisis in environment and energy demand.

## ACKNOWLEDGEMENT

Authors acknowledge the funding agency SERB (DST, GOI) for financial support to carry out this research.

## NOMENCLATURE

$x$	Hydrogen to carbon mole ratio in dry biomass
$y$	Oxygen to carbon mole ratio in dry biomass
$z$	Nitrogen to carbon mole ratio in dry biomass
$w_k$	Number of water molecule in dry biomass
$m$	Number of oxygen molecule
$\lambda$	Equivalence ratio
$F_{H_2}$	Theoretical to actual mole fraction ratio for $H_2$
$F_{CH_4}$	Theoretical to actual mole fraction ratio for $CH_4$
$F_{CO}$	Theoretical to actual mole fraction ratio for CO
$F_{CO_2}$	Theoretical to actual mole fraction ratio for $CO_2$
$K_{mn}$	Reaction rate constant of methanation reaction
$K_{wgs}$	Reaction rate constant of water gas shift reaction
$\Delta g_{mn}^0$	Gibb's free energy for methanation reaction
$\Delta g_{wgs}^0$	Gibbs free energy for water gas shift reaction
$H_2$	Hydrogen gas
CO	Carbon monoxide gas
$CH_4$	Methane gas
$CO_2$	Carbon dioxide gas
AMW	Animal manure waste
$M_B$	Mass of dry biomass
MC	Moisture content
$\dot{N}_{H_2}$	Stoichiometric mole fraction of $H_2$
$\dot{N}_{CO_2}$	Stoichiometric mole fraction of $CO_2$
$\dot{N}_{H_2O}$	Stoichiometric mole fraction of $H_2O$
$\dot{N}_{CH_4}$	Stoichiometric mole fraction of $CH_4$
$\dot{N}_{CO}$	Stoichiometric mole fraction of CO
$\dot{N}_{N_2}$	Stoichiometric mole fraction of $N_2$ gas
$R$	Universal gas constant
$T$	Gasification temperature

$[\dot{N}_{H_2}]_{act}$	Actual mole fraction of H <sub>2</sub>
$[\dot{N}_{CH_4}]_{act}$	Actual mole fraction of CH <sub>4</sub>
$[\dot{N}_{CO}]_{act}$	Actual mole fraction of CO
$[\dot{N}_{CO_2}]_{act}$	Actual mole fraction of CO <sub>2</sub>
$[\dot{N}_{H_2}]_{th}$	Theoretical mole fraction of H <sub>2</sub>
$[\dot{N}_{CH_4}]_{th}$	Theoretical mole fraction of CH <sub>4</sub>
$[\dot{N}_{CO}]_{th}$	Theoretical mole fraction of CO
$[\dot{N}_{CO_2}]_{th}$	Theoretical mole fraction of CO <sub>2</sub>
$LHV_B$	Lower heating value of biomass
$HHV_B$	Higher heating value of biomass
$LHV_g$	Lower heating value of producer gas
CGE	Cold gas gasification efficiency
RSME	Root mean square error
$P_{Straw}$	mass of biomass feedstock from rice straw
$P_{Husk}$	mass of biomass feedstock from rice husk
$P_{AMW}$	Mass of biomass feedstock from AMW
$h_b$	Latent heat of vaporisation for water
$\eta_{MT}$	Mechanical and turbine efficiency combined
$\eta_{CGE}$	Cold gas gasification efficiency
$E_{Estimated}$	Total Estimated energy in TWh
$E_{Rice\ Straw}$	Estimated energy in TWh by Rice Straw
$E_{Rice\ Husk}$	Estimated energy in TWh by Rice Husk
$E_{AMW}$	Estimated energy in TWh by animal manure

## REFERENCES

- Jarungthammachote S. and A. Dutta. 2007. Thermodynamic equilibrium model and second law analysis of a downdraft waste gasifier. *Energy* 32(9): 1660-1669.
- Jirakulsomchok K. and S.S.H. Pisitsungkakarn. 2019. Numerical study of performance of a late mixing porous burner (LMPB) for combustion of low-calorific synthetic-gas from biomass gasification. *International Energy Journal* 19(4): 243-252.
- Barman N.S., Ghosh S., and De S., 2012. Gasification of biomass in a fixed bed downdraft gasifier – A realistic model including tar. *Bioresource technology* 107: 505-511.
- Sasujit K., Dussadee N., Homdoung N., Ramaraj R., and Kiatsiriroat T., 2017. Waste-to-Energy: Producer gas production from fuel briquette of energy crop in Thailand. *International Energy Journal* 17(1): 37-46.
- Mendiburu A.Z., Carvalho Jr J.A., Zanzi R., Coronado C.R., and Silveira J.L., 2014. Thermochemical equilibrium modeling of a biomass downdraft gasifier: Constrained and unconstrained non-stoichiometric models. *Energy* 71: 624-637.
- Enget C. and K. Jaojaruek. 2020. CFD modeling of a downdraft gasifier with woodchips used as feedstock. *International Energy Journal* 20(1): 39-56.
- Melgar A., Pérez J.F., Laget H., and Horillo A., 2007. Thermochemical equilibrium modelling of a gasifying process. *Energy Conversion and Management* 48(1): 59-67.
- Ratnadhariya J.K. and S.A. Channiwala. 2009. Three zone equilibrium and kinetic free modeling of biomass gasifier – A novel approach. *Renewable Energy* 34(4):1050-1058.
- Jess A., 1996. Mechanisms and kinetics of thermal reactions of aromatic hydrocarbons from pyrolysis of solid fuels. *Fuel* 75(12): 1441-1448.
- Tillman D.A., 1978. *Wood as an Energy Resource*. New York: Academic Press.
- Kitani O. and C.W. Hall. 1989. *Biomass Handbook*. New York: Gordon and Breach Science Publishers, pp. 863.
- Pangavhane D.R. and S. Tare. 2012. Grape stalk briquettes as a alternative feedstock of biomass gasifiers. *International Energy Journal* 13: 11-20.
- Rubio M.G.A. and K. Jaojaruek. 2018. Small-scale shaking single-stage downdraft biomass gasifier. *International Energy Journal* 18: 321-330.
- Yan L., Cao Y., and He B., 2018. On the kinetic modeling of biomass/coal char co-gasification with steam. *Chemical Engineering Journal* 331: 435-442.
- Sepe A.M., Li J., and Paul M.C., 2016. Assessing biomass steam gasification technologies using a multi-purpose model. *Energy Conversion and Management* 129: 216-226.
- Shelke G.N. and P. Mahanta. 2016. Feasibility study on utilization of biomass briquette in a conventional downdraft gasifier. *International Energy Journal* 16: 157-166.
- Prins M., van den Berg R., van Holthoon E., van Dorst E., and Geuzebroek F., 2012. Technological developments in IGCC for carbon capture. *Chemical Engineering & Technology* 35(3): 413-419.
- Ong'iro A., Ugursal V.I., Al Taweel A.M., and Lajeunesse G., 1996. Thermodynamic simulation and evaluation of a steam CHP plant using ASPEN Plus. *Applied Thermal Engineering* 16(3): 263-271.
- Doherty W., Reynolds A., and Kennedy D., 2009. The effect of air preheating in a biomass CFB gasifier using ASPEN Plus simulation. *Biomass and Bioenergy* 33(9): 1158-1167.
- Douglas P.L. and B.E. Young. 1991. Modelling and simulation of an AFBC steam heating plant using ASPEN/SP. *Fuel* 70(2):145-154.

- [21] Heyne S., Thunman H., and Harvey S., 2012. Extending existing combined heat and power plants for synthetic natural gas production. *International Journal of Energy Research* 36(5): 670-681.
- [22] Gummert M., Hung N.V., Chivenge P., and Douthwaite B., 2020. *Sustainable Rice Straw Management*. Switzaerland: Springer Nature, pp. 2-3.
- [23] Zafar S., 2018. Rice straw as bioenergy resource. *BioEnergy Consult*. Retrieved from the World Wide Web: <https://www.bioenergyconsult.com/rice-straw-as-bioenergy-resource>.
- [24] Singh R.B., Saha R.C., Singh M., Chandra D., Shukla S.G., Walli T.K., Pradhan P.K., and Kessels H.P.P., 1995. Rice straw, its production and utilization in India. In Singh, K. and Schiere, J.B., ed. *Handbook for straw feeding systems in livestock production*. New Delhi, India, ICAR, pp. 325-339.
- [25] ESCAP (Economic and Social Commission for Asia and the Pacific) and CSAM (Centre for Sustainable Agricultural Mechanization) 2018. Report *Status of Straw Management in Asia-Pacific and Options for Integrated Straw Management*. Retrieved from the World Wide Web: [http://www.un-csam.org/Publication/StatusOfStrawMgrAP\\_final\\_31July2018.pdf](http://www.un-csam.org/Publication/StatusOfStrawMgrAP_final_31July2018.pdf).
- [26] IRRI (International Rice Research Institute), 2009. report *Rice Knowledge Bank for rice husk*. World Wide Web: <http://www.knowledgebank.irri.org/step-by-step-production/postharvest/rice-by-products#rice-husk>.
- [27] IRRI (International Rice Research Institute), 2009. report *Rice Knowledge Bank for rice straw*. World Wide Web: <http://www.knowledgebank.irri.org/step-by-step-production/postharvest/rice-by-products/rice-straw>.
- [28] FAO (Food and Agriculture Organization) of United Nations, 2014. *Statistics for Crop*. Retrieved from the World Wide web: <http://www.fao.org/faostat/en/#data/QC>.
- [29] Fourcault A., Marias F., and Michon U., 2010. Modelling of thermal removal of tars in a high temperature stage fed by a plasma torch. *Biomass and Bioenergy* 34(9): 1363-1374.
- [30] Fuentes-Cano D., Gómez-Barea A., Nilsson S., and Ollero P., 2016. Kinetic modeling of tar and light hydrocarbons during the thermal conversion of biomass. *Energy & Fuels* 30(1): 377-385.
- [31] Morf P., Hasler P., and Nussbaumer T., 2002. Mechanisms and kinetics of homogeneous secondary reactions of tar from continuous pyrolysis of wood chips. *Fuel* 81(7): 843-853.
- [32] Kunze C. and H. Spliethoff. 2011. Modelling, comparison and operation experiences of entrained flow gasifier. *Energy Conversion and Management* 52(5): 2135-2141.
- [33] Zainal Z.A., Ali R., Lean C.H., and Seetharamu K.N., 2001. Prediction of performance of a downdraft gasifier using equilibrium modeling for different biomass materials. *Energy Conversion and Management* 42(12): 1499-1515.
- [34] Wu K.T. and R.Y. Chein. 2015. Modeling of biomass gasification with preheated air at high temperatures. *Energy Procedia* 75: 214-219.
- [35] Gimelli A. and A. Luongo. 2014. Thermodynamic and experimental analysis of a biomass steam power plant: Critical issues and their possible solutions with CCGT systems. *Energy Procedia* 45: 227-236.
- [36] Sittisun P., Tippayawong N., and Pang S., 2019. Biomass gasification in a fixed bed downdraft reactor with oxygen enriched air: A modified equilibrium modeling study. *Energy Procedia* 160: 317-323.



[www.ericjournal.ait.ac.th](http://www.ericjournal.ait.ac.th)

## Does Biomass Energy Consumption Improve Human Development? Evidence from South Asian Countries

Shamal C. Karmaker<sup>\*,#,^</sup>, Shahadat Hosan<sup>\*,#</sup> and Bidyut B. Saha<sup>\*,#,1</sup>

**Abstract** – The effect of biomass energy consumption on the economy, environment, and human development is still a debatable issue, and researchers have not yet been reached any consensus about this issue. Several studies have examined the impact of biomass energy usage concerning economic, environmental, and human wellbeing perspectives and found mixed results. As a large number of people in South Asia are relying on these biomass energy usages, it is obvious to investigate whether the use of biomass energy is contributing positively to human development or not. Thus, this paper enhances the existing literature by exploring the influence of biomass energy usage on human development in South Asian nations in 1990-2016. Panel cointegration approaches, along with a Dumitrescu-Hurlin panel causality test, have been performed to assess the long-run causality between biomass energy use and human development. Our findings suggest that biomass energy usage has an adverse effect on human development in South Asian countries and a bidirectional causal relationship between these two variables. Policymakers might suggest reducing the use of traditional biomass, such as firewood and cow dung cake, to achieve SDG-7 and improve the quality of life.

**Keywords** – Biomass, economic growth, human development, panel cointegration, South Asian countries.

### 1. INTRODUCTION

Energy is an integral component of economic and societal development, and biomass energy is an essential form of energy source, particularly in developing nations. Energy utilization contributes to job creation, agricultural development, industrialization, transportation, and trade development, leading to poverty alleviation and sustainable human development. Over the last century, growing energy consumption has become the main factor in the industrialization and economic development process [1]. Energy plays a significant role in improving a nation's economy, and hence it impacts human welfare. For instance, modern health, education, and communication facilities are directly related to the supply of available energy. The scarcity of energy resources causes poor health services, fewer opportunities for education and growth, and a high likelihood of poverty in the population [2]. Energy consumption is a crucial tool that represents the societal advancement level. It is necessary to generate a sufficient amount of energy for the modernization process to facilitate sustainable development [3].

Industrialization with rapid economic and population growth has led to a growing demand for energy globally. Globally, energy consumption raised around 44% between 1971 and 2014 [4], and approximately 80% of it comes from fossil energy [5]. Dependence on fossil fuels has raised questions about insufficient availability, environmental degradation, and energy safety [6]. Environmental issues are at the center of those concerns. The use of fossil fuels is often seen as a significant element in growing greenhouse gas emissions responsible for climate change and global warming [7]. Renewable energy use can protect the environment for achieving sustainable development goals, for which fossil fuels are replacing it. Besides environmental benefits, renewable energy allows economies to minimize their dependence on foreign resources and increase job opportunities [8]. Renewable energy has the highest growth rate, resulting in rising three times quicker than fossil fuels between 2013 and 2018 [5]. According to IRENA projections, this percentage could rise to 60% by 2050 [9]. Such type of energy production, for example, can prompt economic development and allow those countries to achieve higher rates of human development [10].

Biomass is the form of energy that accounts for the most significant share of renewable energy. Bioenergy contributed 12% of overall total energy consumption in 2018 [5]. The percentage of modern bioenergy in renewable energy used in 2018 (excluding conventional biomass usage) is 50%. As demand increases, researchers are also increasingly paying attention to the impacts of biomass. Although one research group concentrated on the correlation between biomass and economic growth [6], [11], [14], another group looked at the ecological impacts of biomass [15]–[18]. The findings of this research have not reached a consensus.

\*International Institute for Carbon-Neutral Energy Research (WPI-I2CNER), Kyushu University, 744 Motoooka, Nishi-ku, Fukuoka-shi, Fukuoka 819-0395, Japan.

#Mechanical Engineering Department, Kyushu University, 744 Motoooka, Nishi-ku, Fukuoka-shi, Fukuoka 819,0395, Japan.

^Department of Statistics, University of Dhaka, Dhaka-1000, Bangladesh.

<sup>1</sup>Corresponding author;  
E-mail: [saha.baran.bidyut.213@m.kyushu-u.ac.jp](mailto:saha.baran.bidyut.213@m.kyushu-u.ac.jp)



Some studies point out that the use of renewable energy stimulates economic development and is environmentally sustainable, and other studies suggest the reverse. Therefore, it remains a controversial question of whether biomass should be used more or less.

This research would like to add to the current literature by examining the effects of biomass energy use on human wellbeing. United Nations Development Program (UNDP) defines human development as the expansion of human opportunities and choices. For a long period, the per capita Gross Domestic Product (GDP) is often used to measure the HDI; however, economic indicators like GDP do not capture the overall human wellbeing [19]. The HDI has gradually replaced GDP as the primary indicator for assessing human development since UNDP first introduced it in 1990. Considering three aspects like long and healthy life, knowledge, and decent living standards, HDI can reflect the entire quality of human lives. Growing this HDI now becomes a target for almost every country. Policymakers require to consider all three dimensions of sustainable development: cultural, environmental, and social. Nevertheless, earlier research concentrated on the ecological and economic growth impact of biomass energy use and failed to examine human development effects. Investigating the link between biomass energy usage and human development would provide policymakers with a comprehensive analysis of the impacts of biomass energy use on human development.

The traditional use of biomass in developed and developing economies supplies energy for cooking and heating through simple and typically unreliable fires or stoves. In recent years, the quantity of biomass used in traditional applications has marginally declined from an

estimated 27.2 EJ in 2010 to 26 EJ in 2018 [5]. The drop is mainly due to attempts to reduce traditional biomass and advance access to clean energy, given the adverse effects of biomass burning on local air quality and the related health impacts. Biomass energy production and consumption may impact the environment causing deforestation, biodiversity loss, resource depletion, and food insecurity. For instance, traditional forms of biomass usage, such as wood and waste, can generate indoor air pollution that may harm health and the environment [20], [21]. Also, collecting traditional forms of biomass for domestic cooking can also engage the women refraining them from being involved in child care and education [22]. This may be the reason how biomass energy consumption can impede human development. However, biomass energy also may affect society directly by ensuring easy access and secure energy supply to rural people, generating employment, alleviating energy poverty, and helping in economic growth in a country [11]. By providing a neutral balance of carbon emission, biomass energy helps combat climate change accelerated through fossil fuels. Therefore, it can be said that biomass energy may have both positive and negative impacts on human development [23].

This research adds in many ways to the current scope of literature. The most considerable energy use across the globe is linked to human activities. This particular research field has yet to be explored. But quantifying the relationship between energy consumption and HDI may be necessary. Examining the connection between HDI and biomass energy consumption for the South Asian economy is the originality and novelty of this energy research study.

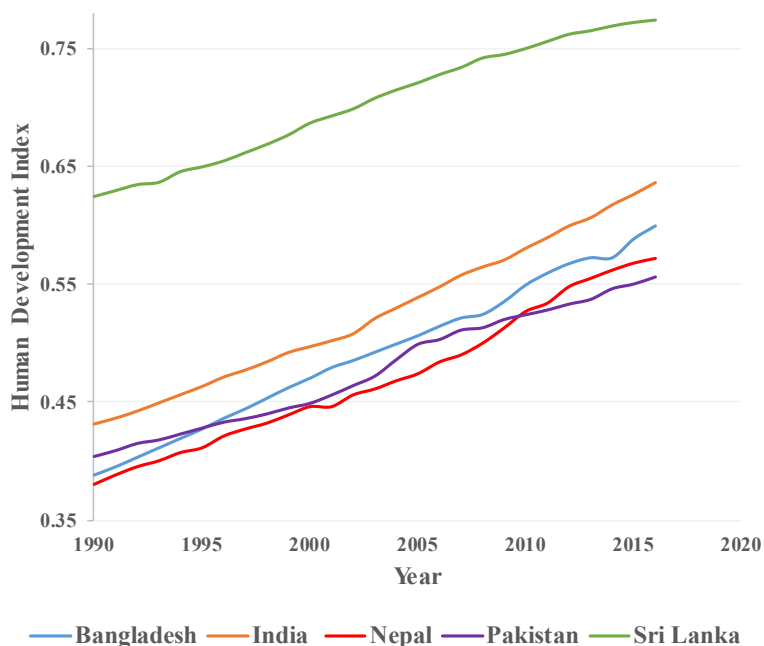

Fig. 1. Trend of human development index in South Asia in 1990 – 2016.

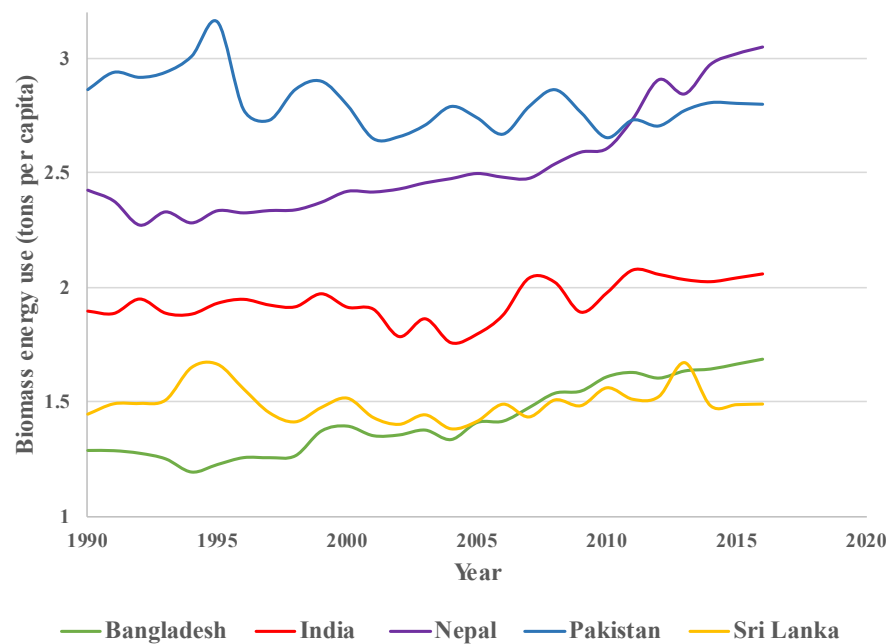

Fig. 2. Trend of biomass energy use in South Asia in 1990 – 2016.

Second, to the best of our knowledge, the relationship between biomass energy consumption and human development is rarely examined in the context of South Asia, where a large number of people depend on biomass energy sources. Biomass is a significant source of energy supply in rural areas, and energy poverty is a common scenario in the South Asian region. The current energy and human development situation in this region is at risk, and this region's energy crisis affects every aspect of the economy and human life. However, SDG-7 says that each country should ensure clean and affordable energy for all within 2030. As a result, South Asian countries require an evaluation of biomass's effects on sustainable human development. The worst condition regarding the energy and human development process in South Asian nations needs time to be managed. This study is an effort to enhance existing literature and help policymakers better understand the effects of biomass energy on the human development process in the South Asian context.

Understanding the importance of biomass energy consumption for human development and the existing energy use pattern in South Asia motivates us to investigate the link between biomass energy consumption, economic growth, and human development to measure whether biomass energy consumption affects the process of human development in this region. Thus, the innovative input of this study is to investigate the relationship between biomass energy use, economic growth, and human development, integrating trade ratio, industrialization, and foreign direct investment for South Asian nations.

## 2. BACKGROUND AND LITERATURE REVIEW

As the purpose of this paper is to explore the impact of biomass usage on human development, it aims to look in-depth at the related literature. Biomass sources will be instrumental in meeting the world's energy demand in the near future. For instance, IEA [24] points out that bioenergy demand would increase by 1.6% on average during 2010- 2035. Researchers have revealed that biomass energy can affect the environment, economy, and resources toward ensuring sustainable development. Energy consumption is often considered as one of the factors of human development. It has been assumed for a while that more energy use contributed to better human development.

Nevertheless, when environmental worries related to energy consumption are increasing, this view is no longer valid. The increased use of energy does not assure higher levels of human development [25]. Martínez and Ebenhack [26] led a study for 120 countries and revealed a robust relationship between energy use and human development. Ouedraogo [2] examined this relationship for 15 developing nations over the 1988-2008 period and found a negative relationship and unidirectional Granger causality between energy usage and human development. Contrary, Tran *et al.* [25] analyzed the relationship for 93 nations with data for the 1990-2014 period and suggested that energy usage does not lead to human development in developing and developed countries. Niu *et al.* [3] found the long-run bidirectional causality between the use of energy and human development for 50 countries for the period of 1990-2009.

The linkage between renewable energy usage and human development is less explored than the energy

consumption-human development nexus. We found only studies [27], [28] relating to the impacts of renewable energy use on human development. But these scholars have presented contradictory findings. Pirlogea [28] concluded that the use of renewable energy promotes human development. Meanwhile, Wang *et al.* [27] found that renewable energy causes the decline of the human development level. It was also pointed out that the higher the income of the country leads to a lower level of human development. Besides, Wang *et al.* [29] examined the effects of biomass on human development for BRICS countries for 1990-2015 and revealed that biomass energy usage increases human development in BRICS countries. The conclusion from the existing studies is controversial, and further research is required on the linkage between renewable energy use and human development. It can also be found from the literature that researchers have ignored the impact of biomass energy usage on human development. This linkage has also not been discussed in South Asian countries. Our research is attempting to fill in that gap.

The rest of this paper is organized as follows: Section 3 describes the methodological approaches used, Section 4 describes the results, while Section 5 outlines the conclusions and policy implications of the findings and addresses possible complementary steps.

### 3. METHODOLOGY

Econometric techniques are applied to check whether there exists a causal relationship between biomass energy consumption and human wellbeing. The methodology comprises the following steps: 1) Panel unit root tests are used to verify the stationarity assumptions of the selected variables. 2) After confirming the non-stationarity of these variables, suitable panel cointegration methods were employed to test whether a cointegrating relationship exists or not. 3) Ensuring the cointegration among variables, parameters are estimated via the dynamic ordinary least squares (DOLS) and the fully modified OLS techniques. 4) Lastly, the Dumitrescu-Hurlin [30] panel causality test is employed to identify one-to-one causal relationships.

#### 3.1 Conceptual Framework

Economic growth is a crucial factor in human development. Ranis and Stewart [31] stated that economic progress provides human development resources. Income can be vastly correlated with education, health, and life expectancy, which stimulates HDI [32]. There is also evidence that economic growth is accompanied by a worsening of the environment and impacts the quality of living standards of present and future generations [33]. The effect of GDP on the HDI, in other words, remains a contentious issue. Some countries can accomplish high HDI with low GDP and vice versa [31].

Biomass energy, unlike other renewable energy sources, can influence economic growth and thus affect

people's incomes, living standards, and purchasing power [12]. As the economy develops, access to health care and education services is made easier for people. In developing nations, biomass energy also supports creating job opportunities and raise the incomes of rural workers resulting in the reduction of poverty [13]. Energy derived from biomass sources is used in electricity generation, cooking, domestic heating, and transportation [5], directly or indirectly affecting human development. Biomass energy helps meet humanity's increasing energy needs, lowers energy costs, and decreases the reliance on fossil fuels [34]. Most specifically, biomass energy is a "carbon-neutral" energy source [35] because if we plant trees to generate biomass energy, it helps to remove CO<sub>2</sub> from the atmosphere. Therefore, biomass energy contributes to mitigate air pollution and protect the environment, which impacts human well-being and life.

Economic growth in developed countries is closely correlated with the industrialization process. Concerning the impact of industrialization on human development, Qasim and Chaudhary [36] find that industrialization affects human development from various aspects. Industrial development impacts directly and indirectly on human health. First, the industrialization process raises labor demand and creates job opportunities [37]. It supports to reduce poverty, increase income, and improve the quality of living standard [38], [39]. Secondly, industrial development boosts the market for the skilled and trained workforce, which in turn raises the demand for education [38]. Also, industrialization may cause pollution, leading to the deterioration of the environment and affecting humans' health and quality of life [40], [41].

Trade openness and foreign direct investment, like industrialization, is regarded as the engine of economic development in developing nations. Trade openness helps to fill the resource gap of a country, whereas foreign direct investment helps fulfill capital needs and helps creates more job opportunities, and thereby helps to increase per capita income [27], [42]. Thus, there is reason to believe that trade openness and foreign direct investment impact the human development process.

Based on the above conceptual framework, the following empirical model used by Wang *et al.* [29] for BRICS countries are considered to examine the relationship between biomass energy consumption and human development for South Asian nations, incorporating economic growth, trade openness, industrialization, and foreign direct investment as control variables:

$$HDI_{it} = f(BIO_{it}, GDP_{it}, TRO_{it}, IND_{it}, FDI_{it}) \quad (1)$$

In Equation 1, HDI denotes the human development index, BIO refers to biomass energy consumption, GDP indicates economic growth, TRO means trade openness, FDI refers to foreign direct investment, while IND is industrialization.

The single multivariate structure is considered to investigate the relationship among variables of interest. At the same time, natural logarithms form of data has been used to reduce variation and smooth the data [44]. This conversion also enables to overcome the problems of autocorrelation and heteroscedasticity and deliver more trustworthy and consistent findings than simple linear form [45]. Our empirical model can express in log-linear form as shown in Equation 1

$$\ln HDI_{it} = \tau_0 + \beta \ln BIO_{it} + \tau_1 \ln GDP_{it} + \tau_2 \ln FDI_{it} + \tau_3 \ln TRO_{it} + \tau_4 \ln IND_{it} + \varepsilon_{it} \quad (2)$$

Where  $i$  represents the number of countries (from 1 to 5),  $t$  refers to the time (1990 to 2016).  $\tau_0$  is the intercept/constant term. The coefficients of biomass energy consumption, economic growth, foreign direct investment, trade openness, and industrialization are denoted by  $\beta$ ,  $\tau_1$ ,  $\tau_2$ ,  $\tau_3$  and  $\tau_4$ , respectively.  $\varepsilon_{it}$  represents the random error term affecting the human development index. Our attention is focused on the coefficient  $\beta$ , which measures the partial effect of biomass energy usage on the human development index.

### 3.2 Panel Unit Root Test

The standard ordinary least square method is not suitable for unit root variables due to spurious regression [46], which makes invalid statistical inference. In this situation, it is important to find the degree of integration for each variable in Equation 1. There are several panel unit root tests used by researchers for identifying the stationarity of variables, such as Levin *et al.* [47], Im *et al.* [48], Breitung [49], and Hadri [50].

Two forms of panel unit root tests, LLC and IPS, are used for exploring the unit root [47]. The simple form of the LLC test for estimation is presented in Equation 3:

$$\Delta(HDI)_{it} = w_{it}\gamma_i + \rho(HDI)_{it-1} + \sum_{j=1}^{k_i} \varphi_{ij}\Delta(HDI)_{i,t-j} + \varepsilon_{it} \quad (3)$$

Where  $\Delta$  is used as an operator of the first difference,  $w_{it}$  refers to the fixed-effects and varying time trends, and  $k$  is the lag order. The null hypothesis state that all series are non-stationary ( $H_0: \rho = 0 \forall i$ ) versus the alternative that all variables are stationary ( $H_1: \rho < 0 \forall i$ ). However, LLC assumes  $\rho_i = \rho \forall i$ , i.e., homogenous  $\rho$  for all  $i$ . Violation of the above assumptions makes the accuracy of the LLC test ineffective [49]. To overcome this problem, Im *et al.* (2003) suggested a unit root test (hereafter IPS), allowing  $\rho$  to vary overall  $i$ . The IPS model is shown in Equation 4:

$$\Delta(HDI)_{it} = w_{it}\gamma_i + \rho_i(HDI)_{it-1} + \sum_{j=1}^{k_i} \varphi_{ij}\Delta(HDI)_{i,t-j} + \varepsilon_{it} \quad (4)$$

The null hypothesis ( $H_0: \rho_i = 0$ ) denotes that every variable in the panel has a unit root versus the

alternative ( $H_1: \rho_i < 0$ ), which implies that at least one variable is stationary in the panel.

### 3.3 Panel Cointegration Test

If the series has a unit root, a cointegration test can be used to examine the long-run causal relationship among the variables. There are some panel cointegration testing procedures, including Pedroni [51], [52], Kao [53], Maddala and Wu [54], and Westerlund [55]. In the current study, Pedroni and Kao's methods have been employed. Based on cointegration regression residuals from Engel and Granger (1987), Pedroni suggested seven different statistics, which include the panel ADF-statistic ( $Z_{ADF}$ ), panel PP statistic ( $Z_{PP}$ ), panel rho-statistic ( $Z_\rho$ ), panel- $v$  statistic ( $Z_v$ ), group ADF statistic ( $Z_{ADF}^g$ ), and group PP statistic ( $Z_{PP}^g$ ), group rho statistic ( $Z_\rho^g$ ). Among seven tests, four belong to within dimension, and the other three are considered between dimension tests. Within the extent, tests are further extended to weighted and unweighted statistics. The above statistics are calculated based on the mean of the individual autoregressive coefficients related to the residuals' unit root tests for all cross-sectional units. The long-run model for estimating the residuals for the above test is presented, as shown in Equation 5:

$$Y_{it} = \beta_i + \tau_i t + \sum_{j=1}^m \gamma_{ji} X_{jit} + \varepsilon_{it} \quad (5)$$

where,  $i = 1, 2, \dots, N$ ;  $t = 1, 2, \dots, T$  and  $j = 1, 2, \dots, m$  represent the cross-sectional units, number of cases and number of predictors, respectively. The estimated residuals structure can be represented, as shown in Equation 6:

$$\varepsilon_{it} = \rho_i \varepsilon_{it-1} + u_{it} \quad (6)$$

All seven tests indicate that there is no cointegration ( $H_0: \rho_i = 1 \forall i$ ) against the alternative ( $H_1: \rho_i < 1$ ) suggests the existence of cointegration. The Kao test is also constructed in the same way as the Pedroni tests, considering the homogeneous slope coefficients in Equation 5, not allowing for differing individual panel members.

### 3.4 Panel DOLS and FMOLS Estimates

The long-run relationship coefficient can be estimated when the variables are confirmed as cointegrated in the panel data set. When the variables are cointegrated, the ordinary least squares (OLS) method is not appropriate for estimating the long-run coefficients. Nonetheless, dynamic ordinary least squares (DOLS) and fully modified ordinary least squares (FMOLS) methods are appropriate in these cases. The long-run coefficients in Equation 1 are estimated applying the group means dynamic OLS (DOLS) and fully modified OLS (FMOLS) estimators developed by Pedroni [52], [56].



The group-means FMOLS is known as a non-parametric approach, while the DOLS estimator is a parametric approach where explicitly estimated the lagged first-differenced terms [46]. Both DOLS and FMOLS techniques consider serial correlation and endogeneity. There is a conflict, whether FMOLS or DOLS is better. However, Kao and Chiang [57], for example, showed that the parametric DOLS method is better than the FMOLS method [52].

On the contrary, it shows that DOLS has a little smaller size distortion than the FMOLS. Therefore, in this study, we applied both DOLS and FMOLS methods and then test for statistically significant differences in the coefficient in Equation 1. Pedroni [52] suggests the following equation for cointegrated panel data:

$$Y_{it} = \alpha_i + \delta X_{it} + \varepsilon_{it} \quad (7)$$

Where  $X$  and  $Y$  have a long-run association. Pedroni [56] proposes an additional equation, which includes lagged differences as an independent variable to control for the endogenous response effect, as shown in Equation 8:

$$Y_{it} = \alpha_i + \delta X_{it} + \sum_{k=-k_i}^{k_i} \gamma_{ik} \Delta X_{it-k} + \varepsilon_{it} \quad (8)$$

Pedroni defines  $\eta_{it} = (\hat{\varepsilon}_{it}, \Delta X_{it})$  and long-run

$$\text{covariance } \varphi_{it} = \lim_{T \rightarrow \infty} E \left[ \frac{1}{T} \left( \sum_{t=1}^T \eta_{it} \right) \left( \sum_{t=1}^T \eta_{it} \right)' \right].$$

The decomposition of this covariance matrix can be presented as  $\varphi_{it} = \varphi_i^0 + \omega_i + \omega_i'$ , where,  $\varphi_i^0$  denotes contemporaneous covariance and  $\omega_i$  represents the weighted sum of autocovariance. Hence, the estimator of panel FMOLS is presented, as shown in Equation 8 below:

$$\hat{\delta}_{FMOLS}^* = \frac{1}{N} \sum_{i=1}^N \left[ \left( \sum_{t=1}^T (X_{it} - \bar{X}_i)^2 \right)^{-1} \left( \sum_{t=1}^T (X_{it} - \bar{X}_i) Y_{it}^* - T \hat{\gamma}_i \right) \right] \quad (9)$$

$$\text{where, } Y_{it}^* = Y_{it} - \bar{Y}_i - \left( \hat{\eta}_{2,1,i} / \hat{\eta}_{2,2,i} \right) \Delta X_{it} \quad \text{and} \\ \hat{\gamma}_i = \hat{\omega}_{2,1,i} + \hat{\eta}_{2,1,i}^0 - \left( \hat{\eta}_{2,1,i} / \hat{\eta}_{2,2,i} \right) \left( \hat{\omega}_{2,2,i} + \hat{\eta}_{2,2,i} \right)$$

### 3.5 Dumitrescu and Hurlin Panel Causality Test

For the support of policymakers, additional information can be gathered by examining the causal relationship between variables of interest using the Dumitrescu and Hurlin [30] panel causality test. To overcome the problem of heterogeneity and cross-sectional dependency [29], [59] and also to handle both situations where  $N < T$  and  $N > T$  as well as the unbalanced panel, this method is appropriate [60]. In this testing procedure, the following model has employed to assess the causal relationship between variable  $X$  and  $Y$ :

$$Y_{it} = \alpha_i + \sum_{k=1}^K \delta_i^{(k)} Y_{i,t-k} + \sum_{k=1}^K \gamma_i^{(k)} X_{i,t-k} + \varepsilon_{i,t} \quad (10)$$

Where  $\alpha_i$  represents concept/intercept term,  $K$  denotes

lag length,  $\delta_i^{(k)}$  is a lag parameter

$\gamma_i = (\gamma_i^{(1)}, \gamma_i^{(2)}, \dots, \gamma_i^{(K)})$ , while  $\gamma_i^{(k)}$  is slope coefficient.

Cross-section unit differences are represented by  $\delta_i^k$  and  $\gamma_i^k$ .

Assuming no causal relationship in the panel known as a null hypothesis against the causal relationship exists in at least one cross-section unit as an alternative hypothesis. The Wald statistic for all panel is measured by taking the average of all the individual Wald statistic for every cross-section:

$$W_{N,T}^{hnc} = \frac{1}{N} \sum_{i=1}^N W_{i,T} \quad (11)$$

Where  $W_{i,T}$  represents the individual Wald statistic values for each cross-section.

In the case of  $T > N$ , the average statistic  $W_{N,T}^{hnc}$  is suggested by Dumitrescu and Hurlin [30] as shown in Equation 12:

$$Z_{N,T}^{hnc} = \sqrt{\frac{N}{2K}} \left( W_{N,T}^{hnc} - K \right) \quad (12)$$

### 3.6 Data Sources

Twenty-seven years of annual data from 1990 to 2016 are collected for biomass energy consumption, human development index, per capita GDP, foreign direct investment, industrialization, and trade openness in five South Asian countries – Bangladesh, India, Nepal, Pakistan, and Sri Lanka. The human development index is measured from the database of UNDP [61], whereas data on biomass energy consumption is gathered from the Global Material Flows Database [62]. The remaining variables, such as GDP, foreign direct investment, trade openness, and industrialization, are derived from World Development Indicators [63]. Economic growth is measured as per capita GDP (in constant 2010 US Dollar); biomass energy consumption is calculated as tons per capita; the trade openness is considered as the ratio of total exports and imports to GDP (*i.e.*, as % of GDP); and industrialization is measured as the percentage of the value-added of the industry in GDP. Balanced panel data with  $N * T = 135$  observations where  $N=5$  and  $T=27$  are considered in this study. The summary statistics of the analyzed data, including mean, standard deviations, and the minimum and maximum values, are detailed in Appendix A.

#### 4. RESULTS AND DISCUSSION

The results for the entire sample are presented in this section. It is essential to check whether data are unit-roots or non-stationary as a precondition for testing of

cointegration. In this study, the LLC (Levin, Lin, Chu) and IPS (Im, Pesaran, Shin) techniques were employed to identify the presence of unit roots in the series. A summary of these two test results is detailed in Table 1.

**Table 1. Panel unit root tests.**

Variable	LLC		IPS	
	Level	Ist difference	Level	Ist difference
lnHDI	1.14 [0.87]	-4.03*** [0.00]	0.41 [0.66]	-3.79*** [0.00]
lnBIO	-1.91* [0.09]	-9.82*** [0.00]	-0.58 [0.28]	-9.07*** [0.00]
lnGDP	0.51 [0.69]	-5.64*** [0.00]	1.35 [0.91]	-5.57*** [0.00]
lnIND	-1.94* [0.08]	-5.70*** [0.00]	-1.35* [0.09]	-5.93*** [0.00]
lnTRO	-0.98 [0.16]	-9.66*** [0.00]	0.09 [0.54]	-8.95*** [0.00]
lnFDI	-0.43*** [0.00]	-15.20*** [0.00]	-4.18*** [0.00]	-14.69*** [0.00]

[] indicates p-value; Significant at (\* 10% \*\* 5%, \*\*\* 1%) level.

**Table 2. Panel cointegration tests.**

Test	Statistics	P-value
Panel PP statistic	-2.062**	0.0196
Panel PP statistic (Weighted)	-1.782**	0.0374
Group PP statistic	-2.046**	0.0204
Panel ADF statistic	-2.254**	0.0121
Panel ADF statistic (Weighted)	-1.811**	0.0351
Group ADF statistic	-1.337*	0.0907
Kao test statistic	-2.144**	0.0160

Significance level (\* 10% \*\* 5%, \*\*\* 1%) for rejecting the null hypothesis of no cointegration.

It is clear from both tests that there is no evidence to reject the null hypothesis at the level for all series, but at the first difference, the hypothesis is rejected at the 1% level for all series. Therefore, based on the LLC and IPS tests, all six variables seem to be I (1). Hence, all variables in Equation 1 consists of unit root properties, and the process is I (1).

Panel cointegration techniques are utilized to measure the long-run association among the variables in Equation 1, as the panel series in this study. A number of test results, containing Panel PP statistic, group PP statistic, Panel ADF statistic, group ADF statistic, and Kao attributable to Pedroni [51] and Kao [53], are displayed in Table 2. The hypothesis of no cointegration in the panel is rejected at 5% level based on the results in Table 2, supporting a long-run relationship exists among the studied variables.

Based on the long-run relationship identified among the studied variables, the next step is to assess the long-run coefficients in Equation 1. Two novel statistical estimation techniques, such as the fully

modified ordinary least squares (FMOLS) and dynamic ordinary least squares (DOLS), were applied for country-specific long-run parameter estimates based on assuming no trend and group estimation. The estimated coefficients, standard errors, and p-values of the predictor variables are detailed in Table 3, where the regressed variable is the human development index (lnHDI).

The effect of biomass energy consumption on human development ( $\beta$ ) is of primary interest. Both approaches provide similar results suggesting biomass energy consumption has a negative impact on human development in the long-run. For all South Asian nations, negative relationships were identified, contrary to the findings obtained for BRICS countries by Wang *et al.* [29]. Nevertheless, the analysis conducted by Wang *et al.* [29] for BRICS countries found that a negative relationship with India supports our results. The production and consumption of biomass energy can cause loss of biodiversity, deforestation, depletion of resources, and food insecurity.

**Table 3. Estimation of the long-run coefficient.**

Nations	FMOLS					DOLS				
	Predictors									
	lnBIO	lnGDP	lnTRO	lnFDI	lnIND	lnBIO	lnGDP	lnTRO	lnFDI	lnIND
Bangladesh	-0.216 (0.149)	0.444*** (0.090)	0.089** (0.034)	0.012** (0.005)	-0.361* (0.179)	-0.274 (0.297)	0.467 (0.233)	0.031 (0.042)	0.027 (0.013)	-0.290 (0.474)
India	-0.112*** (0.015)	0.289*** (0.005)	0.037*** (0.006)	0.006*** (0.001)	-0.080*** (0.019)	-0.142* (0.053)	0.283*** (0.013)	0.043* (0.015)	0.004 (0.002)	-0.068 (0.037)
Nepal	-0.429*** (0.084)	0.703*** (0.046)	-0.002 (0.028)	-0.001 (0.001)	-0.047*** (0.035)	-0.013 (0.152)	0.285* (0.115)	0.216** (0.063)	0.003** (0.001)	-0.329** (0.062)
Pakistan	-0.347*** (0.067)	0.856*** (0.031)	-0.060* (0.033)	-0.002 (0.006)	0.179** (0.048)	-0.282** (0.059)	0.955*** (0.034)	-0.064* (0.025)	-0.008** (0.002)	0.341*** (0.057)
Sri Lanka	-0.096* (0.047)	0.194*** (0.017)	0.031 (0.022)	-0.006 (0.006)	0.179*** (0.062)	-0.219** (0.066)	0.182** (0.038)	-0.003 (0.050)	0.003 (0.028)	0.102 (0.136)

Significant at (\* 10% \*\* 5%, \*\*\* 1%) level. Standard error represents in ().

**Table 4. Dumitrescu-Hurlin panel causality tests, p-values are shown in parentheses.**

Dependent variable	Independent variable					
	lnHDI	lnBIO	lnGDP	lnIND	lnTRO	lnFDI
lnHDI	-	4.347* (0.055)	5.104*** (0.009)	2.653 (0.697)	2.703 (0.665)	1.619 (0.587)
lnBIO	6.760*** (0.000)	-	6.366*** (0.000)	2.168 (0.961)	4.066* (0.097)	3.585 (0.219)
lnGDP	5.962*** (0.000)	4.539** (0.037)	-	2.136 (0.938)	1.934 (0.795)	1.231 (0.372)
lnIND	9.088*** (0.000)	7.818*** (0.000)	8.986*** (0.000)	-	7.775*** (0.000)	4.570** (0.034)
lnTRO	5.446*** (0.004)	2.897 (0.543)	4.175* (0.078)	5.160*** (0.008)	-	2.836 (0.580)
lnFDI	4.635** (0.029)	2.846 (0.574)	3.429 (0.277)	3.816 (0.151)	3.252 (0.353)	-

Significant at (\* 10% \*\* 5%, \*\*\* 1%) level.

Moreover, traditional forms of biomass use, such as wood and waste, can affect both health and the environment. Collecting traditional forms of biomass for domestic cooking may also include women who refrain from participating in child care and education [22]. That may be the reason why the consumption of biomass energy in South Asian countries hampers human development. Policymakers may suggest reducing the use of traditional biomass, such as firewood and cow dung cake, to achieve sustainable development and improve the quality of life. On the other hand, the GDP coefficient is statistically positive and significant at the 5% significance level, which indicates that GDP has a positive impact on human development.

After measuring the long-run coefficients, we used Dumitrescu and Hurlin [30] technique to evaluate the causal relationships between variables taken in this paper. The results of the Dumitrescu-Hurlin heterogeneous panel causality test are presented in Table 4. These results reveal the presence of bidirectional causality between human development and biomass energy usage. The long-run coefficients estimated in Table 4 help policymakers to suggest clean energy sources by reducing traditional biomass energy for these

South Asian countries to achieve SDG-7. This test also offers a two-way relationship between human development and economic growth. A similar finding is suggested by Wang *et al.* [29] and Sinha and Sen [64] in BRIC countries.

## 5. CONCLUSION AND POLICY IMPLICATIONS

The panel cointegration approach, along with a Dumitrescu-Hurlin panel causality test, has been used to examine the long-run linkage between biomass energy usage and human development for South Asian countries over the period of 1990-2016. The study reveals the existence of long-run causality between human development and biomass energy usage. However, biomass energy usage has an adverse effect on human development. Based on the results of this paper, policy implications can be drawn that excessive traditional biomass energy usage can play an adverse effect on human development, particularly in developing countries (in this case, South Asian countries). Clean energy (such as biogas and biofuel) and clean cooking technology can accelerate human development for South Asian countries and contribute to achieving SDG's goal-

7. The government should encourage people to adopt clean cooking technologies by ensuring the necessary policy and incentives. The government may also continue the awareness program for using improved cooking stoves in rural areas in South Asian countries. Our results also reflect that economic growth is a crucial factor for human development in the South Asian region. Therefore, policy initiatives are required to accelerate economic growth for human development. Governments in the South Asian region can offer more budgetary allocation for health services, education, poverty alleviation, environmental protection, and clean energy technology development.

Finally, notwithstanding the important results acknowledged in this paper, there are some limits worthy of exploration in future research. This study can be conducted for other case studies. Also, more informal measures, for example, interviews and household level investigation, can offer a robust additional finding. The effect of biomass energy use on human welfare in the context of advanced nations or other regions will support policymakers with a comprehensive policy guideline regarding the impact of biomass energy usage. Besides, we emphasize investigating the impact of biomass energy use on human development, ignoring the specific biomass energy source forms. This is the constraint of this study that can be explored in future research focusing on additional nations and economies over extended periods as data becomes available.

#### ACKNOWLEDGEMENT

We would like to thank the anonymous referees for their helpful comments, which significantly improved the paper. The corresponding author is also thankful to Dr. Laura Marsiliani and Dr. Thomas Renström from Durham University Business School, United Kingdom.

#### REFERENCES

- [1] Warr B.S. and R.U. Ayres. 2010. Evidence of causality between the quantity and quality of energy consumption and economic growth. *Energy* 35: 1688–1693. <https://doi.org/10.1016/j.energy.2009.12.017>.
- [2] Ouedraogo N.S., 2013. Energy consumption and human development: Evidence from a panel cointegration and error correction model. *Energy* 63: 28–41. <https://doi.org/10.1016/j.energy.2013.09.067>.
- [3] Niu S., Jia Y., Wang W., He R., Hu L., Liu Y., 2013. Electricity consumption and human development level: A comparative analysis based on panel data for 50 countries. *Int. J. Electr. Power Energy Syst.* 53: 338–347. <https://doi.org/10.1016/j.ijepes.2013.05.024>.
- [4] Eren B.M., Taspinar N., Gokmenoglu K.K., 2019. The impact of financial development and economic growth on renewable energy consumption: Empirical analysis of India. *Sci. Total Environ.* 663: 189–197. <https://doi.org/10.1016/j.scitotenv.2019.01.323>.
- [5] REN21, 2020. Renewables, 2020 Global Status Report. <http://www.ren21.net/resources/publications/>.
- [6] Bilgili F., Koçak E., Bulut Ü., Kuşkaya S., 2017. Can biomass energy be an efficient policy tool for sustainable development? *Renew. Sustain. Energy Rev.* 71: 830–845. <https://doi.org/10.1016/j.rser.2016.12.109>.
- [7] Baek J., 2016. Do nuclear and renewable energy improve the environment? Empirical evidence from the United States. *Ecol. Indic.* 66: 352–356. <https://doi.org/10.1016/j.ecolind.2016.01.059>.
- [8] Alper A. and O. Oguz. 2016. The role of renewable energy consumption in economic growth: Evidence from asymmetric causality *Renew. Sustain. Energy Rev.* 60: 953–959. <https://doi.org/10.1016/j.rser.2016.01.123>.
- [9] IRENA, 2018. Global energy transformation: A roadmap to 2050.
- [10] Kazar G. and A. Kazar. 2014. The renewable energy production-economic development Nexus. *Int. J. Energy Econ. Policy.* 4: 312–319.
- [11] Aydin M., 2019. The effect of biomass energy consumption on economic growth in BRICS countries: A country-specific panel data analysis. *Renew. Energy* 138: 620–627. <https://doi.org/10.1016/j.renene.2019.02.001>.
- [12] Bildirici M. and F. Özaksoy. 2018. An analysis of biomass consumption and economic growth in transition countries. *Econ. Res. Istraz.* 31: 386–405. <https://doi.org/10.1080/1331677X.2018.1427610>
- [13] Ozturk I. and F. Bilgili. 2015. Economic growth and biomass consumption nexus: Dynamic panel analysis for Sub-Sahara African countries. *Appl. Energy* 137: 110–116. <https://doi.org/10.1016/j.apenergy.2014.10.017>.
- [14] Shahbaz M., Rasool G., Ahmed K. and Mahalik M.K., 2016. Considering the effect of biomass energy consumption on economic growth: Fresh evidence from BRICS region. *Renew. Sustain. Energy Rev.* 60: 1442–1450. <https://doi.org/10.1016/j.rser.2016.03.037>.
- [15] Adewuyi A.O. and O.B. Awodumi. 2017. Biomass consumption, economic growth and carbon emissions: Fresh evidence from West Africa using a simultaneous equation model. *Energy* 119: 453–471. <https://doi.org/10.1016/j.energy.2016.12.059>.
- [16] Danish and Z. Wang. 2019. Does biomass energy consumption help to control environmental pollution? Evidence from BRICS countries. *Sci. Total Environ.* 670: 1075–1083. <https://doi.org/10.1016/j.scitotenv.2019.03.268>.
- [17] Dogan E. and R. Inglesi-Lotz. 2017. Analyzing the effects of real income and biomass energy consumption on carbon dioxide (CO<sub>2</sub>) emissions:



- Empirical evidence from the panel of biomass-consuming countries. *Energy* 138:721–727. <https://doi.org/10.1016/j.energy.2017.07.136>.
- [18] Shahbaz M., Balsobre-Lorente D. and Sinha A., 2019. Foreign direct Investment–CO 2 emissions nexus in Middle East and North African countries: Importance of biomass energy consumption. *J. Clean. Prod.* 217: 603–614. <https://doi.org/10.1016/j.jclepro.2019.01.282>.
- [19] Cracolici M.F., Cuffaro M. and Nijkamp P., 2010. The measurement of economic, social and environmental performance of countries: A novel approach. *Soc. Indic. Res.* 95: 339–356. <https://doi.org/10.1007/s11205-009-9464-3>.
- [20] Fullerton D.G., Bruce N. and Gordon S.B., 2008. Indoor air pollution from biomass fuel smoke is a major health concern in the developing world. *Trans. R. Soc. Trop. Med. Hyg.* 102: 843–851. <https://doi.org/10.1016/j.trstmh.2008.05.028>.
- [21] Oluwole O., Otaniyi O.O., Ana G.A., Olopade C.O., 2012. Indoor air pollution from biomass fuels: A major health hazard in developing countries. *J. Public Heal.* 20: 565–575. <https://doi.org/10.1007/s10389-012-0511-1>.
- [22] Behera B., Rahut D.B., Jeetendra A. and Ali A., 2015. Household collection and use of biomass energy sources in South Asia. *Energy* 85: 468–480. <https://doi.org/10.1016/j.energy.2015.03.059>.
- [23] Jingjing L., Xing Z., DeLaquil P. and Larson E.D., 2001. Biomass energy in China and its potential. *Energy Sustain. Dev.* 5: 66–80. [https://doi.org/10.1016/S0973-0826\(08\)60286-0](https://doi.org/10.1016/S0973-0826(08)60286-0).
- [24] IEA, 2019. International Energy Agency. World Energy Outlook.
- [25] Van Tran N., Van Tran Q., Do L.T.T., Dinh L.H., Do H.T.T., Trade off between environment, energy consumption and human development: Do levels of economic development matter?. *Energy* 173 : 483–493. <https://doi.org/10.1016/j.energy.2019.02.042>.
- [26] Martínez D.M. and B.W. Ebenhack, 2008. Understanding the role of energy consumption in human development through the use of saturation phenomena. *Energy Policy.* 36: 430–1435. <https://doi.org/10.1016/j.enpol.2007.12.016>.
- [27] Wang Z., Danish, Zhang B., Wang B., 2018. Renewable energy consumption, economic growth and human development index in Pakistan: Evidence form simultaneous equation model. *J. Clean. Prod.* 184: 1081–1090. <https://doi.org/10.1016/j.jclepro.2018.02.260>.
- [28] Pirlogea C., 2012. The human development relies on energy. panel data evidence. *Procedia Econ. Financ.* 3: 496–501. [https://doi.org/10.1016/s2212-5671\(12\)00186-4](https://doi.org/10.1016/s2212-5671(12)00186-4).
- [29] Wang Z., Bui Q. and Zhang B., 2020. The relationship between biomass energy consumption and human development: Empirical evidence from BRICS countries. *Energy* 194: 116906. <https://doi.org/10.1016/j.energy.2020.116906>.
- [30] Dumitrescu E.I. and C. Hurlin. 2012. Testing for Granger non-causality in heterogeneous panels. *Econ. Model.* 29: 1450–1460. <https://doi.org/10.1016/j.econmod.2012.02.014>.
- [31] Ranis G. and F. Stewart. 2005. Dynamic Links between the Economy and Human Development. 050: 1–16.
- [32] Shah S., 2016. Determinants of human development index: A cross-country empirical analysis. *Int. J. Econ. Manag. Stud.* 3: 43–46. <https://doi.org/10.14445/23939125/ijems-v3i5p106>.
- [33] Rudra A. and A. Chattopadhyay. 2018. Environmental quality in India: Application of environmental Kuznets curve and Sustainable Human Development Index. *Environ. Qual. Manag.* 27: 29–38. <https://doi.org/10.1002/tqem.21546>.
- [34] Bonechi C., Consumi M., Donati A., Leone G., Magnani A., Tamasi G. and Rossi C., 2017. 1 - Biomass: An overview. *Bioenergy Syst. Futur.*
- [35] Sikka M., Thornton T.F. and Worl R., 2013. Sustainable biomass energy and indigenous cultural models of wellbeing in an Alaska forest ecosystem, *Ecol. Soc.* 18. <https://doi.org/10.5751/ES-05763-180338>.
- [36] Qasim M. and A.R. Chaudhary. 2015. Determinants of human development disparities: A cross district analysis of Punjab, Pakistan. *Pak. Dev. Rev.* 54: 427–446. <https://doi.org/10.30541/v54i4i-iiip.427-446>.
- [37] Shahbaz M. and H.H. Lean, 2012. Does financial development increase energy consumption? The role of industrialization and urbanization in Tunisia, *Energy Policy* 40: 473–479. <https://doi.org/10.1016/j.enpol.2011.10.050>.
- [38] D.K. S Upadhyaya, How industrial development matters to the wellbeing of the population: Some statistical evidence, Vienna: UNIDO. (2014).
- [39] O. Oyeyinka, Industrial Clusters, Institutions, and Poverty in Nigeria, 2017. [https://doi.org/10.1007/978-3-319-41151-4\\_1](https://doi.org/10.1007/978-3-319-41151-4_1).
- [40] M. Nazeer, U. Tabassum, S. Alam, Environmental pollution and sustainable development in developing countries, *Pak. Dev. Rev.* 55 (2016) 589–604. <https://doi.org/10.30541/v55i4i-iiip.589-604>.
- [41] A.J. Bailey, Industrialization and economic development in advanced placement human geography, *J. Geog.* 99 (2000) 142–152. <https://doi.org/10.1080/00221340008978909>.
- [42] Reiter S.L. and H.K. Steensma. 2010. Human development and foreign direct investment in developing countries: The influence of FDI policy and corruption. *World Dev.* 38: 1678–1691. <https://doi.org/10.1016/j.worlddev.2010.04.005>.
- [43] Khan N.H., Ju Y. and Hassan S.T., 2019. Investigating the determinants of human development index in Pakistan: an empirical analysis. *Environ. Sci. Pollut. Res.* 26: 19294–19304. <https://doi.org/10.1007/s11356-019-05271-1>.

- [44] Zafar M.W., Shahbaz M., Hou F. and Sinha A., 2019. From nonrenewable to renewable energy and its impact on economic growth: The role of research & development expenditures in Asia-Pacific Economic Cooperation countries. *J. Clean. Prod.* 212: 166–1178. <https://doi.org/10.1016/j.jclepro.2018.12.081>.
- [45] Shahbaz M., Zeshan M. and Afza T., 2012. Is energy consumption effective to spur economic growth in Pakistan? New evidence from bounds test to level relationships and Granger causality tests. *Econ. Model.* 29: 2310–2319. <https://doi.org/10.1016/j.econmod.2012.06.027>.
- [46] Harris R. and R. Sollis, 2003. Applied Time Series Modelling. John Wiley & Sons Ltd., West Sussex.
- [47] Levin A., Lin C.F. and Chu C.S.J., 2002. Unit root tests in panel data: Asymptotic and finite-sample properties. *J. Econom.* 108: 1–24. [https://doi.org/10.1016/S0304-4076\(01\)00098-7](https://doi.org/10.1016/S0304-4076(01)00098-7).
- [48] Im K.S., Pesaran M.H. and Shin Y., 2003. Testing for unit roots in heterogeneous panels, *J. Econom.* 115: 3–74. [https://doi.org/10.1016/S0304-4076\(03\)00092-7](https://doi.org/10.1016/S0304-4076(03)00092-7).
- [49] Breitung J. 2005. The local power of some unit root tests for panel data. Humboldt-Universität Zu Berlin. Wirtschaftswissenschaftliche Fak.
- [50] Hadri K., 2000. Testing for stationarity in heterogeneous panel data. *Econom. J.* 3: 148–161. <https://doi.org/10.1111/1368-423x.00043>.
- [51] Pedroni P., 1999. Critical values for cointegration tests in heterogeneous panels with multiple regressors. *Oxf. Bull. Econ. Stat.* 61: 653–670. <https://doi.org/10.1111/1468-0084.61.s1.14>.
- [52] Pedroni P., 2000. Fully modified OLS for heterogeneous cointegrated panels., nonstationary panels. *Panel Cointegration Dyn. Panels.* 15: 93–130.
- [53] Kao C., Spurious regression and residual-based tests for cointegration in panel data. *J. Econom.* 90: 1–44. [https://doi.org/10.1016/S0304-4076\(98\)00023-2](https://doi.org/10.1016/S0304-4076(98)00023-2).
- [54] Maddala G.S. and S. Wu, 1999. A comparative study of unit root tests with panel data and a new simple test. *Oxf. Bull. Econ. Stat.* 61: 631–652. <https://doi.org/10.1111/1468-0084.61.s1.13>.
- [55] Westerlund , 2001. Testing for error correction in panel data. *Oxf. Bull. Econ. Stat.* 69: 709–748. <https://doi.org/10.1111/j.1468-0084.2007.00477.x>.
- [56] Pedroni P. 2001. Purchasing power parity tests in cointegrated panels. *Rev. Econ. Stat.* 83: 727–731. <https://doi.org/10.1162/003465301753237803>.
- [57] Kao C.D. and M.-H. Chiang. 2012. On the Estimation and Inference of a Cointegrated Regression in Panel Data. *SSRN Electron. J.* <https://doi.org/10.2139/ssrn.1807931>.
- [58] Koçak E. and A. Şarkgüneşi. 2017. The renewable energy and economic growth nexus in black sea and Balkan Countries. *Energy Policy.* 100: 51–57. <https://doi.org/10.1016/j.enpol.2016.10.007>.
- [59] Dogan E. and F. Seker. 2016. Determinants of CO2 emissions in the European Union: The role of renewable and non-renewable energy. *Renew. Energy.* 94: 429–439. <https://doi.org/10.1016/j.renene.2016.03.078>.
- [60] UNDP, 2019. Human Development data (1990–2018) [Human Development Report 2019, 2019. Retrieved from the World Wide Web: <http://hdr.undp.org/en/data>.
- [61] UN Environment Programme International Resource Panel Global Material Flows Database, 2019. Retrieved from the World Wide Web: <https://www.resourcepanel.org/global-material-flows-database>.
- [62] B. World, 2019. Data Bank: World Development Indicators. Retrieved from the World Wide Web: <https://databank.worldbank.org/source/world-development-indicators>.
- [63] Sinha A. and S. Sen. 2016. Atmospheric consequences of trade and human development: A case of BRIC countries. *Atmos. Pollut. Res.* 7: 980–989. <https://doi.org/10.1016/j.apr.2016.06.003>.

## APPENDIX A

Table A1. Summary statistics of national data during 1990-2016.

Country	Variable	Mean	Standard Deviation	Minimum	Maximum
Bangladesh	HDI	0.491	0.063	0.388	0.599
	BIO	1.421	0.159	1.193	1.689
	GDP	635.059	195.191	411.165	1062.040
	FDI	0.628	0.551	0.004	1.74
	IND	23.649	1.836	20.146	27.346
	TRO	31.401	9.078	16.477	47.150
India	HDI	0.526	0.063	0.431	0.637
	BIO	1.938	0.087	1.758	2.077
	GDP	1035.67	387.534	575.502	1874.229
	FDI	1.17	0.885	0.027	3.62
	IND	28.348	1.590	26.442	31.137
	TRO	25.816	9.875	12.944	43.035
Nepal	HDI	0.471	0.060	0.380	0.572
	BIO	2.531	0.236	2.272	3.052
	GDP	505.597	115.770	354.258	731.999
	FDI	0.204	0.188	0.0001	0.548
	IND	28.348	1.590	26.442	31.137
	TRO	37.073	4.634	24.148	45.459
Pakistan	HDI	0.478	0.049	0.404	0.556
	BIO	2.810	0.117	2.653	3.159
	GDP	899.098	111.215	741.004	1117.518
	FDI	1.15	0.867	0.383	3.67
	IND	21.446	1.647	18.257	25.528
	TRO	31.114	3.240	24.124	37.815
Sri Lanka	HDI	0.704	0.050	0.625	0.774
	BIO	1.494	0.075	1.379	1.671
	GDP	2192.162	803.254	1189.664	3769.159
	FDI	1.233	0.495	0.430	2.85
	IND	27.844	1.449	25.850	30.642
	TRO	57.004	12.291	35.792	71.711

Data sources: UNDP [61], Global Material Flows Database [62] and World Development Indicators [63].



[www.ericjournal.ait.ac.th](http://www.ericjournal.ait.ac.th)

# A Comparative Study of Microgrid Policies for Rural Electricity Transition between Bangladesh and Thailand

Thongchai Meenual<sup>\*,+</sup> and Parnuwat Usapein<sup>\*,1</sup>

**Abstract** – This paper is an exploratory study on the Bangladesh and Thailand rural electricity transition. This study compares the Bangladesh microgrid policies with that of Thailand microgrid policies. The comparative study in several areas considers electricity security, electricity access, environmental sustainability, economic development and growth of the countries. Public data related to microgrid policies in Bangladesh and Thailand had been collected, analyzed and discussed. The comparative case brings out the significant differences while also exploring the range of possible synergies across different dimensions and sectors. Concisely, the transition of rural electricity, driven by microgrid policy in both countries can be achieved by adopting new electricity market structure and regulation. The private sector would play a key role in electricity generation.

**Keywords** – Bangladesh microgrid, microgrid policy, renewable energy, rural electricity transition, Thailand microgrid.

## 1. INTRODUCTION

Driving the goal of affordable and clean electricity is a global challenge to fulfill an ambition to achieve a better and more sustainable future. Renewable distributed energy resources have the potential to bring about affordable and clean electricity. It is a significant constituent of the microgrid in an electricity transition. The microgrid presents a way to provide electricity supply in remote areas and a way to use clean and renewable energy [1]. Under some circumstances, the microgrid may be the best way to supply electricity [2].

A pathway toward the electricity sector transformation from fossil-based to less-CO<sub>2</sub> is known as the electricity transition. The microgrid enables the electricity transition because of its predominant part, renewable energy source [3]. Renewable energy potentially provides a large proportion of CO<sub>2</sub> reduction in the electricity sector [4].

Electricity transition in rural areas provides direct and indirect social and economic benefits, from poverty alleviation to better health and education facilities [5]. Several studies have examined the transition of rural electricity access in different countries and regions. Dagnachew *et al.* identified the barriers to electricity access and relevant actors to provide policy recommendations in Sub-Saharan Africa [6]. Yadav *et al.* studied the lessons of a transition to decentralized rural electrification in India [7]. Derks and Romijn explored the challenges of rural microgrids policy in

Indonesia, in which the problem was to understand key determinants of microgrid un/sustainability [8]. While there is available literature analyzing rural electrification at individual national and regional levels, there is no recent comparative study on the difference in electricity transition, based on microgrid policies, between two countries. One is with full electricity access, and another is with a different level of electricity access.

Two countries in Asia, Bangladesh and Thailand, are in a transition period of the transformation of affordable and clean electricity. These two countries share some similarities and have some distinctions of rural electricity transition. Exploring these two countries is expected to reveal insights about the national electricity transition in an economically-developing country context. The objective of this study is to investigate the rural electricity transition of Bangladesh and Thailand. Policies related to rural microgrids of two countries are explored. The emerging roles of the microgrid in energy policy in a period of electricity transition are studied. The comparative case study methodology has been applied to conduct this study. Publicly available data of Bangladesh and Thailand rural microgrids from reliable databases, *e.g.*, World Bank, United Nation, World Energy Council, World Economic Forum, have been retrieved, collected, analyzed, discussed, and concluded. This exploratory study will reveal the understanding of the rural electricity transition in two selected economically-developing countries.

## 2. LITERATURE REVIEW

### 2.1 Rural Electricity Transition

The World Economic Forum declared that in the economically-developing countries, accelerating access to sustainable energy was essential to the energy transition [11]. Because of dramatic cost declines in solar photovoltaics and energy storage, renewable energy isolated microgrids provided electricity to 150

\*Rattanakosin College for Sustainable Energy and Environment, Rajamangala University of Technology Rattanakosin, Nakhon Pathom, Thailand.

<sup>+</sup> Provincial Electricity Authority, Bangkok, Thailand.

<sup>1</sup> Corresponding author;

Tel: + 66 (0)841457026.

E-mail: [parnuwat.usa@rmutr.ac.th](mailto:parnuwat.usa@rmutr.ac.th)



million people in the past decade [11]. The Energy Transition Index (ETI), a part of the Fostering Effective Energy Transition initiative of the World Economic Forum, was a fact-based framework to foster a greater understanding of the state and readiness of energy systems for this transition. The ETI framework consisted of two parts: (i) system performance imperatives or Energy Triangle, and (ii) transition readiness enabling dimensions or Enabling Dimensions in short [12]. The Energy Triangle consisted of (i) energy access and security, (ii) environmental sustainability, and (iii) economic development and growth. The Enabling Dimensions consisted of (i) energy system structure, (ii) capital and investment, (iii) regulations and political commitment, (iv) institutions and governance, (v) infrastructure and innovative business environment, and (vi) human capital and consumer participation.

Adapted from the World Economic Forum definition of energy transition [12], the electricity transition is a transition towards a more inclusive, sustainable, affordable, and secure electricity system that provided solutions to electricity-related challenges, while creating value for business and society, without compromising the balance of three goals – (i) electricity access and security, (ii) environmental sustainability, and (iii) economic development and growth.

The rural electricity transition could be accomplished by using microgrids. The microgrids were proposed to provide sufficient electricity for productive uses, generating incomes, in rural areas because of the technical feasibility to build them in most parts of economically-developing countries [13]. The expansion from one experimental-model microgrid to a larger scale was a challenge because of the technical difficulties and the additional socio-economic and regulatory barriers. A regulatory approach for the integration of microgrids and their generation capacities into the national grid was suggested to be a part of the policy framework. In rural areas, microgrid customers had a low ability to pay, thus a low payment rate. The increase in non-paying customers could affect the financial sustainability of the microgrid business. The loss of financial sustainability could interrupt the microgrid continuity, a loss of the electricity service for a rural community.

## 2.2 Microgrid

In 1882, Thomas Edison's first Manhattan Pearl Street electrical power plant, direct current distribution power lines, battery energy storages, and a set of basic electrical control equipment were the first recorded microgrid [14].

A microgrid is a “collection of controllable and physically proximate distributed generator and load resources, incorporating multiple sources of AC power, at least one of which is based on a renewable energy source” [3]. It is worth noting that in this study, the microgrid deals with electricity, rather than other forms of energy. The microgrid constituents are: (i) distributed generation units, (ii) electricity distribution systems, (iii)

protection and control units, and (iv) electrical loads [15], [16].

The distributed generation units can be: (i) the conversion of primary fossil fuel to electricity by, for example, reciprocating engine generators, gas turbines, or microturbines; or (ii) renewable energy resources, such as solar, wind, biomass, biogas, and mini-hydro. The latter speed up the progress of the electricity transition. The electricity distribution system of the microgrid can be a medium voltage system and a low voltage system. It mainly includes, for example, poles, wires, cables, and electrical insulators. The protection and control units make the microgrid more reliable and optimal. Information and communication technologies play significant roles in all microgrid constituents, especially in the protection and control units. The microgrid protection and controller make the microgrid smarter. The electrical loads consume electricity. The increasing digital loads require high power quality and reliability of electricity. It is important noting that electricity consumers have an additional role in producing electricity, rather than only electricity consumption. They become prosumers. In addition, electric vehicles, specifically the battery energy storage inside the electric vehicles, have the new unique characteristics of both electricity consumption and electricity supply. The battery energy storage connected to the grid can also perform the same behavior.

Rural microgrids could incorporate renewable energy resources, often as an addition to diesel/gas generator-based units, and sometimes battery energy storage and mobile payment platforms [2]. The rural microgrids allowed economically-developing countries to potentially leapfrog to a world of smart electricity supply, in a similar way that mobile communications provided them to connect to others both in and outside their community.

## 2.3 Microgrid Policy

Public policy refers to (i) the announcements of principles, wishes, requirements, ideas, actions, interventions, and plans; and (ii) putting the announced statements into action [17]. The survey in three large economic zones, *i.e.*, the European Union, the USA, and China, showed few microgrid studies on effective policies, incentives, and barriers to microgrid promotion and deployment [2], [18]. A finding of the survey showed the key policy drivers that changed the role of microgrids from a secondary energy supply to a primary one.

In the European Union, microgrids and their affiliations, *i.e.*, renewable energy sources and distributed generation, were the solution to European electrical system problems. Three challenging 2030 targets consisted of (i) greenhouse gas reduction of environmental sustainability; (ii) renewable energy penetration; and (iii) energy efficiency. However, there were no specific policies and regulations for distributed

generation and microgrid systems in the European Union.

In the USA, state governments formulated and adopted different microgrid policies, *e.g.*, the 2005 Energy Policy Act, Renewable Portfolio Standard, Renewable Energy Standard, and Energy Efficiency Resource Standard. This measure is: (i) to diversify the energy mix with a high percentage of renewable energy and distributed energy resources, (ii) to reduce the carbon intensity of the electricity sector, and to increase the use of distributed energy resources and more localized distributed generation units.

In China, more than 70 microgrid policies involved research and development, promotion, utilization, incentives, and prevention of environmental issues on all the renewable energy technologies, including solar PV, wind, mini-hydro, thermal, biogas, geothermal, and bioenergy. The renewable energy and distributed generation policies aimed to promote the microgrid concept and microgrid facilities. These microgrid policies were, for example, in the 2005 Renewable Energy Law, the Medium and Long-Term Development Plan for Renewable Energy, and the 12<sup>th</sup> Five-Year Plan for Renewable Energy.

In sum, the microgrid policies of renewable energy resource and distributed generation adoption and promotion in three large economic zones aimed: (i) to increase energy security, (ii) to raise environmental sustainability, and (iii) to promote economic development and growth.

Some typical microgrid policies are (i) financial incentives, *e.g.*, the exemption of transmission use of system charges and transmission loss charges, and the exemption of climate change tax for renewable energy, (ii) legal renewable energy obligation, (iii) interconnection regulation, (iv) power quality and reliability issues and standards, (v) economic benefits of a whole society, (vi) open participation in an electricity market, and (vii) less CO<sub>2</sub> emission [19].

### 3. CASES:

#### 3.1 Bangladesh Cases

In Bangladesh, information on microgrids in government documents, *i.e.*, the Renewable Energy Policy of Bangladesh, the Revisiting Power System Master Plan (PSMP) 2016, and the Power and Energy Sector Strategy Paper reflected the 7th of Sustainable Development Goal (SDG7) – “clean energy for everyone: secure access to affordable, reliable, sustainable and modern energy for everyone,” renewable energy, institutional arrangement, resource, technology, incentive, tariff, penalty, and regulatory setting [20], [21], [22]. In addition to the three mentioned government documents, data from related documents and databases have been collected.

Bangladesh declared the electricity transition as an ambition to achieve the SDG7. Renewable energy sources play significant roles in the process of electricity

transition by diversifying energy sources. The integration of renewable energy in electricity generation into the main grid was planned. In doing so, regulations and standards related to grid-connected renewable energy sources were required. The proportion of renewable energy to the total electricity generation was 3.5% in the baseline year of 2015 and 10% in the targeted year of 2020 [22]. Besides, the renewable energy-based capacity would be 2,800 MW by 2021 and 9,400 MW by 2041 to reach the 10% target [21]. The energy efficiency measure was aimed at increasing system reliability and reducing the dependency on foreign energy sources. In Bangladesh, it was demand-side management. The study on the demand side management recommended energy-saving behavior, as a strategy, to potentially reduce energy consumption in a range of 0.5–21.9% [23]. The distribution systems and components, *e.g.*, lines, substations, monitor and control units, were planned to be upgraded and modernized. They were recommended to become a smart grid.

The microgrid development in Bangladesh was both grid-connected and isolated microgrids. They might be called on-grid and off-grid microgrids, respectively. In 2018, the installed capacity of isolated renewable electricity supply was 289.8 MW, whereas the installed capacity of grid-connected supply was 40.0 MW. The isolated renewable electricity supply had an installed capacity, about 7 times, higher than the grid-connected supply. It was noticed that parts of microgrid, mainly renewable distributed generation units, were developed, studied, and reported. The complete isolated microgrid might be in an early stage of development. The grid-connected microgrids, typically developed by electric utilities, had their planned cumulative capacity of 2,833.0 MW by 2041 [21]. This total capacity consisted of 2,322.0 MW of solar electricity, 510 MW of wind electricity, and 1 MW of biomass-based electricity. The major renewable distributed generation was based on solar, a solar home system in particular [5]. It was worth noting that the 230 MW hydropower plant and the 413.51 MW cumulative solar electricity sources shared portions of the total 647.44 MW renewable electricity installed capacity [24].

From an aspect of rural electricity access, about 80 rural electrification cooperatives under the supervision of the Bangladesh Rural Electrification Board were set up, operated, and maintained rural electricity distribution systems as well as supplied electricity to about 25.2 million customers [25]. However, households, getting connected to the expanded rural electricity grid, remained low as compared to the total number of rural households. Poor households had a lower electrification rate as compared to non-poor households because of the high upfront cost of getting connected to the electricity grid and other constraints, *e.g.*, income/distance of line, revenue collection efficiency, cost of service, and losses [5].

The participation of private investors was in the Revisiting Power System Master Plan 2016 and a record

of the Sustainable and Renewable Energy Development Authority [21], [26]. Stakeholders from private sectors extended the national capabilities to design, plan, construct, install, operate, and maintain the development projects. Private participation contributed to the acceleration of the rural electricity transition, *e.g.*, renewable energy development and microgrid development.

### 3.2 Thailand Cases

In Thailand, a microgrid, a sprout of smart grid, has been in the National Power Development Plan, the Thailand Smart Grid Development Master Plan, and the Thailand 5-year Smart Grid Development Action Plan, for a decade. The microgrid constituent, especially the renewable distributed generation, has been in the Alternative Energy Development Plan. One of the microgrid affiliations, energy efficiency, has been a policy in the Energy Efficiency Plan for about five years. Instruments of energy efficiency policy were, for example, energy efficiency resource standard, soft loan, and tax incentive.

It was observed that there was no explicit SDG7 in all above-mentioned plans [27]-[31]. However, Thailand has been in the process of transition to sustainable, affordable, and clean electricity for all. The renewable electricity sources, including the solar home systems, were in both on-grid and off-grid microgrids. The microgrid development in Thailand had taken place in various places for different purposes. Most of the microgrids were on-grid. Developed at the Chiang Mai Rajabhat University, an exceptional campus off-grid microgrid was a direct current, rather than an alternating current microgrid. The campus microgrids were mainly aimed at creating a body of knowledge about microgrids. The main aim of the utility microgrids of three state-owned enterprises and other government agencies was to learn and demonstrate microgrids and to strengthen the power quality and reliability of the main grid. The business microgrids of private companies were primarily aimed at creating value-added solutions and generating revenue.

The promotion of renewable energy was obviously in the Alternative Energy Development Plan and the existence of renewable energy sources in several locations. The planned target of renewable energy installed capacity was 1,876 MW in total by 2047. Electricity from renewable energy sources increased from 5,960 GWh (4.3%) in 2007 to 17,217 GWh (9.9%) in 2014. In terms of installed capacity, electricity from renewable energy sources in 2017 was 10,949 MW or 23.8%. Electricity from solar shared the largest proportion of the total planned capacity. The most popular renewable energy was solar photovoltaic. A proportional order of the installed capacity was biomass,

wind, biogas, and waste, respectively. In 2019, the Ministry of Energy promoted the initiative of the very small biomass community power plant. It was not only the promotion of renewable energy but also the economic growth of the community. This initiative was in the process of effective action.

From an aspect of rural electricity access, Provincial Electricity Authority (PEA), the largest distribution electric utility in Thailand, has constructed, operated, maintained, and expanded the electricity grids to rural areas for about six decades. Households in the protected and environmentally sensitive areas or on remote islands have been challenges of Thailand's rural electrification. All villages in other areas are 100% electrified. The Thailand electricity access rate is high because of the free-of-charge electricity consumption when electricity consumption was not more than 100 kWh in the past or is not more than 50 kWh at present.

There were various roles of the private sector participation in the microgrid development, including renewable distributed generation. With solar rooftop, private individuals and families in areas electrified from the main grid became solar electricity producers in addition to electricity consumers. These cases usually were the on-grid sources. However, some cases in marginalized rural areas were the off-grid sources, the solar home system in particular. In a renewable energy market, the private sector was active in several business activities, *e.g.*, design, installation, and maintenance. Thailand had the national capabilities to do these business activities.

### 3.3 Case Comparison

Both Bangladesh and Thailand are in Asia. Bangladesh is in South Asia. Thailand is in Southeast Asia. They had some similarities and differences, as shown in Table 1, Figures 1 and 2 [32]-[35].

Bangladesh had ranked 168<sup>th</sup> in electricity consumption per capita with the annual per capita consumption of 336.46 billion kWh in 2018, while Thailand had ranked 94<sup>th</sup> with the number of 2,735.72 billion kWh per capita [36]. The annual electricity consumption per capita of Bangladesh was eight times less than that of Thailand. One of the reasons for this is that Bangladesh had less access to electricity than Thailand (as shown in Table 1), causing the electricity consumption per capita to remain low, despite the higher unmet demand.

The ratio of non-RE and RE electricity capacity, it indicated that Bangladesh had lower electricity from RE than Thailand. More than 90% of electricity generation came from fossil fuel, while less than 2% came from renewable energy, for example, hydro and solar (as shown in Figure 1) [32], [33], [36].

**Table 1. Bangladesh and Thailand data.**

Item	Bangladesh	Thailand	References
Region	South Asia	Southeast Asia	[32], [33]
Total area (sq. km)	147,570	513,120	[32], [33]
Population in 2019	163,046,161	69,625,582	[32], [33]
GNI per capita 2019 (\$US)	1,940	7,260	[32], [33]
Access to electricity (% of population 2016)	76	100	[34], [35]
Electricity consumption per capita in 2019 (billion kWh/person)	336.46	2,735.52	[36]
Non-RE: RE electricity capacity 2018	98:2	78:22	[34], [35]
CO <sub>2</sub> emissions (metric tons per capita 2014)	0.474	4.62	[34], [35]

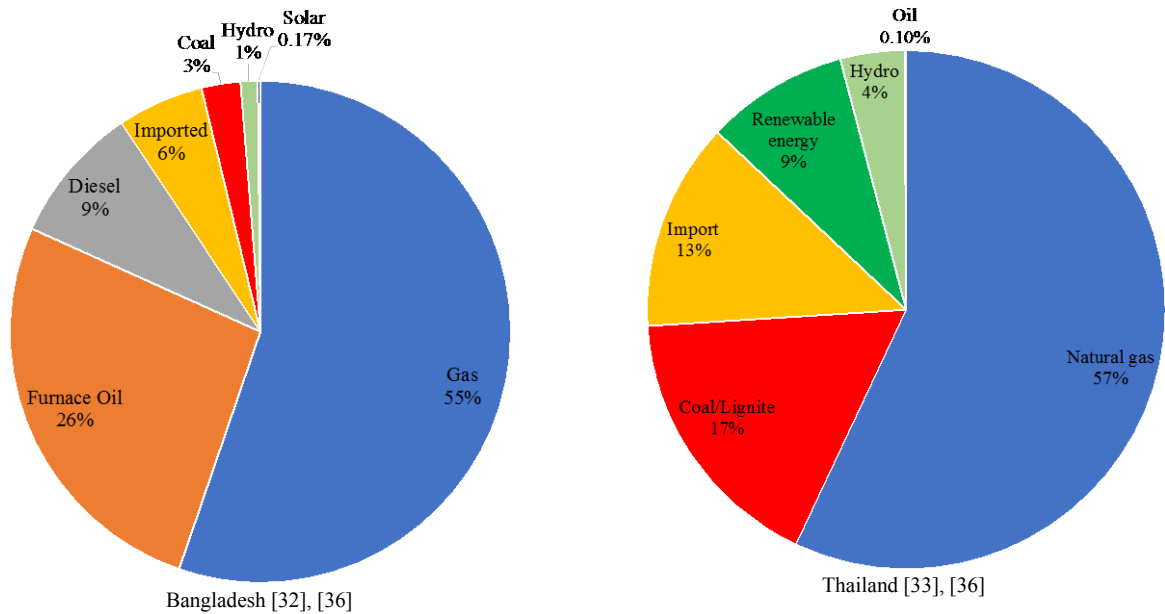

**Fig. 1. Electricity generation based on fuel in 2018.**

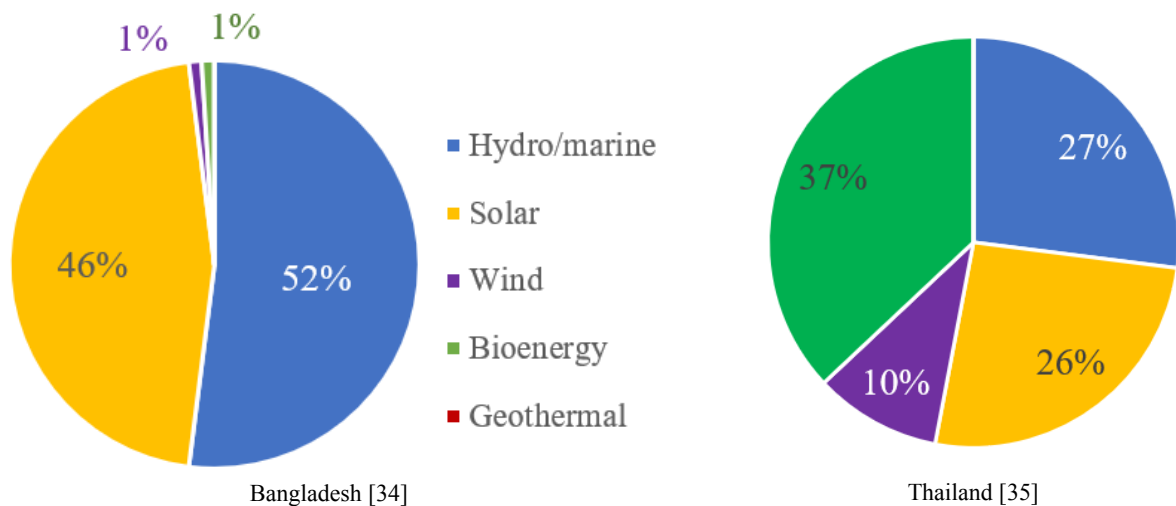

**Fig. 2. Renewable capacity in 2018.**

Both countries were dependent on gas for the majority of the electricity generation. However, Thailand seemed to have more energy diversity, especially renewable energy. About 98% of the total renewable capacity in Bangladesh was solar and

hydropower, while Thailand had a more diverse range of renewable energy sources from bioenergy, solar, hydro, and wind (as shown in Figure 2). To enhance Bangladesh energy security, a diverse range of renewable energy should be promoted.



#### 4. DISCUSSION

Collected evidence showed that both Bangladesh and Thailand were in an electricity transition process. It was clear that both countries aimed to make their electricity supply more secure. Several measures, including microgrids, were applied to increase the electrified areas and to upgrade and expand the electricity grid. The grid had better power quality and reliability.

Bangladesh had more challenges than Thailand to achieve (i) a higher rate of electricity access and (ii) more clean electricity, renewable energy in particular. However, the CO<sub>2</sub> emission of Bangladesh was much less and better than that of Thailand. In other words, Bangladesh was more environmentally-friendly than Thailand. The future of Bangladesh's CO<sub>2</sub> emission will depend on how the country supplies the increasing consumption of electricity. It can be expected to be higher with rising gross national income (GNI) per capita.

In Bangladesh, an electricity access rate was low, to some extent, because of the low ability to pay customers in rural areas. In Thailand, two state-owned distribution electric utilities provided free-of-charge electricity to customers who consume a little electricity. In rural areas, Bangladesh developed the off-grid electricity supply more than Thailand. This might result from the low coverage of the grid in Bangladesh, compared to Thailand.

In Bangladesh and Thailand, both solar energy and hydro energy played a significant role in the renewable electricity supply, the clean energy supply. Bioenergy, *i.e.*, biomass and biogas, had the highest proportion to Thailand's renewable electricity capacity, whereas hydro is the highest in proportion in Bangladesh's renewable electricity capacity. Wind energy had a 1% share of Bangladesh's renewable electricity capacity, whereas it had a 10% share of the Thailand's renewable electricity capacity.

Microgrids in Thailand revealed more constituents than those in Bangladesh. It seemed that Thailand had more opportunity than Bangladesh to diversify the renewable electricity supply. Microgrids already were set as an electricity policy in the Thailand Power Development Plan and the Thailand Smart Grid Development Master Plan. Microgrids are recommended for Bangladesh to make renewable electricity supply better and accelerate a process of rural electricity transition. Based on the collected data, Bangladesh had more unelectrified areas than Thailand. Bangladesh was likely to have more opportunities to make an investment in microgrids than Thailand. If the appropriate microgrid technologies, well-designed microgrids, and well-planned microgrid projects are implemented cost of initial investment, operation of microgrids, and the microgrid sustainability can be enhanced. Bangladesh might accomplish the rural electricity transition, especially in a sense of environmental sustainability, faster than Thailand.

From an investment perspective, investors tend to acquire and deploy new technologies when such technologies lead to lower costs and/or higher profits, the short payback period. In the case of rural electrification, most people in rural areas still had low income and low ability to pay for electricity. This might delay the innovation of microgrid technologies. In both Bangladesh and Thailand, microgrids can take place together with new actors, including private investors. This might demand a new electricity market structure and regulation. In a new circumstance, even the government agencies themselves have to adapt to the new structure if the microgrids are widespread.

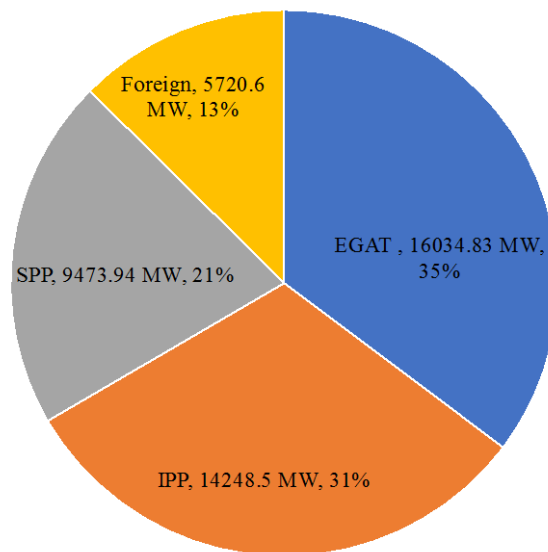

[Adapted from [37]]

**Fig. 3. Thailand electricity generation capacity.**

In Thailand, private power producers could be divided into three categories: Independent Power Producer, Small Power Producers, and Very Small Power Producer (VSPP) as shown in Figure 3. It was expected that the private sector would play a key role in electricity generation (especially VSPP or Distributed Generation) when microgrid started. The private sector in Bangladesh played a role as the electrical equipment supplier in electrical power systems (including microgrids). Other roles of the private sector as power producer, distribution, supervision, and control of the electrical power systems in Bangladesh were in the early stages. The electricity market structure, rules, and regulations should be newly introduced and/or adjusted in Bangladesh to sufficiently incentivize the private sector.

Private participation in Bangladesh and Thailand enhanced the national capabilities to deal with microgrids and their affiliations. The private sector of the electricity industry could accelerate the electricity transition towards more inclusive, sustainable, affordable, and secure electrical power systems.

World Energy Council [9] and the World Economic Forum [11], suggest in cases of Bangladesh and

Thailand, the rural electricity transition should take the country context, including economic development and growth, into consideration, in addition to (i) electricity access and security, and (ii) environmental sustainability. Several cases of the microgrid in the European Union, the USA, China, India, and Indonesia gave a direction of electricity transition. In short, microgrids were necessary for the electricity transition, especially in rural areas.

## 5. CONCLUSION

This study investigates rural electricity transition in Bangladesh and Thailand from the perspective of microgrid policies by using public data. The comparative case study, the methodology of the study, revealed similarities and differences between the electricity transition in rural areas of two cases. The findings show, in a period of the electricity transition, (i) the necessity of renewable distributed electricity generation, and (ii) the emerging roles of the microgrid and the private participation in the energy policy. The electricity transition ensures a way towards a more affordable, clean, secure, and sustainable electricity system. Private participation, electricity market structure, and regulations are the study areas of both practitioners and scholars in the field of energy policy.

## ACKNOWLEDGEMENT

The authors would like to thank (i) Rattanakosin College for Sustainable Energy and Environment, Rajamangala, University of Technology Rattanakosin, and (ii) Provincial Electricity Authority. Authors also acknowledge with thanks comments from referees which helped immensely to improve the initial draft submitted.

## REFERENCES

- [1] International Electrotechnical Commission [IEC], 2017. IEC TS 62898-1 Edition1.0 2017-05 MICROGRIDS – Part 1: Guidelines for microgrid projects planning and specification, ed.
- [2] Hirsch A., Parag Y., and Guerrero J., 2018. Microgrids: A review of technologies, key drivers, and outstanding issues. *Renewable and Sustainable Energy Reviews* 90: 402-411.
- [3] International Electrotechnical Commission [IEC], 2014. Microgrids for disaster preparedness and recovery with electricity continuity plans and systems. 978-2-8322-1151-9.
- [4] IRENA, 2020. *Global Renewables Outlook: Energy transformation 2050*. Retrieved July 23, 2020 from the World Wide Web: [www.irena.org/publications](http://www.irena.org/publications).
- [5] Palit D. and A. Chaurey. 2011. Off-grid rural electrification experiences from South Asia: Status and best practices. *Energy for Sustainable Development* 15: 266-276.
- [6] Dagnachew A.G., Hof A.F., Roelfsema M.R., and van Vuuren D.P., 2020. Actors and governance in the transition toward universal electricity access in Sub-Saharan Africa. *Energy Policy* 143: 111572.
- [7] Yadav P., Davies P.J., and Palit D., 2019. Distributed solar photovoltaics landscape in Uttar Pradesh, India: Lessons for transition to decentralised rural electrification. *Energy Strategy Reviews* 26: 100392.
- [8] Derks M. and H. Romijn. 2019. Sustainable performance challenges of rural microgrids: Analysis of incentives and policy framework in Indonesia. *Energy for Sustainable Development* 53: 57-70.
- [9] World Energy Council, 2019. World Energy Trilemma Index | 2019. World Energy Council, London.
- [10] World Energy Council, 2020. Innovation Insights Brief | 2020. World Energy Council, London 2020.
- [11] World Economic Forum, 2019. Accelerating access to sustainable energy: A key priority in energy transition. World Economic Forum 2019.
- [12] World Economic Forum, 2020. Fostering Effective Energy Transition 2020 edition. World Economic Forum.
- [13] Peters J., Sievert M., and Toman M.A., 2019. Rural electrification through mini-grids: Challenges ahead. *Energy Policy* 132: 27-31.
- [14] Asmus P., 2018. *The Microgrid Revolution*. Retrieved March 12, 2018 from the World Wide Web: <http://peterasmus.com/journal/2009/11/6/the-microgrid-revolution.html>
- [15] Hatzigargyriou N., Asano H., Irvani R., and Marnay C., 2007. Microgrids an overview of ongoing research, development and demonstration projects. *IEEE Power & Energy Magazine* :78-84. Retrieved from the World Wide Web: <http://eetd.lbl.gov/EA/EMP/emp-pubs.html>
- [16] Bower W., Ton D., Guttromson R., Glover S., Stamp J., Bhatnagar D., and Reilly J., 2014. The advanced microgrid integration and interoperability. Sandia National Laboratories SAND2014-1535, 2014.
- [17] Anyebe A.A., 2018. An overview of approaches to the study of public policy. *International Journal of Political Science (IJPS)* 4:8-17.
- [18] Ali A., Li W., Hussain R., He X., Williams B., and Memon A., 2017. Overview of current microgrid policies, incentives and barriers in the European Union, United States and China. *Sustainability* 9: 1146.
- [19] Mariam L., Basu M., and Conlon M.F., 2016. Microgrid: Architecture, policy and future trends. *Renewable and Sustainable Energy Reviews* 64: 477-489.
- [20] Power Division, 2008. Renewable Energy Policy of Bangladesh. Power Division, Ministry of Power Energy and Mineral Resources, Ed.

- [21] Power Division, 2018. Revisiting power system master plan (PSMP) 2016. Power Division, Ministry of Power Energy and Mineral Resources, Ed., 2018 ed.
- [22] Programming Division, 2018. Power and Energy Sector Strategy Paper (SSP). Programming Division, Ministry of Planning, Ed., 2018 ed.
- [23] Khan I., 2019. Energy-saving behaviour as a demand-side management strategy in the developing world: The case of Bangladesh. *International Journal of Energy and Environmental Engineering* 10: 493-510.
- [24] Sustainable and Renewable Energy Development Authority, 2020. *SREDA | National Database Of Renewable Energy : Renewable Energy Installed Capacity*. Retrieved from July 29, 2020. from the World Wide Web: <http://www.renewableenergy.gov.bd/index.php>.
- [25] Bangladesh Rural Electrification Board, 2020. *At a glance BREB Program*. Retrieved July 20, 2020 from the World Wide Web: <http://www.reb.gov.bd/site/page/c08b56bd-c300-4d08-8ea2-c25eedffbfdb/->.
- [26] Sustainable and Renewable Energy Development Authority, 2020. *SREDA | All Stakeholder of Renewable Energy | Counted Number: 112*. Retrieved July 25, 2020 from the World Wide Web: <https://solar.sreda.gov.bd/stakeholder/view/>.
- [27] EPPO, 2019. Thailand Power Development Plan 2018-2037 (PDP2018). Energy Policy and Planning Office (EPPO). Ministry of Energy.
- [28] EPPO, 2015. Thailand Smart Grid Development Master Plan (2015-2036). Energy Policy and Planning Office (EPPO). Ministry of Energy.
- [29] EPPO, 2016. Thailand Smart Grid Action Plan (2017-2021). Energy Policy and Planning Office (EPPO) Ministry of Energy.
- [30] DEDE, 2015. Alternative Energy Development Plan (AEDP2015). Department of Renewable Energy Development and Energy Efficiency (DEDE), Ministry of Energy.
- [31] Ministry of Energy, 2015. Energy Efficiency Plan; EEP 2015. Ministry of Energy.
- [32] World Bank Group. The World Bank | Data Bangladesh [Online]. Retrieved from the World Wide Web: <https://data.worldbank.org/country/bangladesh?view=chart>.
- [33] World Bank Group. The World Bank | Data Thailand [Online]. Retrieved from the World Wide Web: <https://data.worldbank.org/country/thailand?view=chart>.
- [34] IRENA. Statistical profile Bangladesh [Online]. Retrieved from the World Wide Web: [https://www.irena.org/IRENADocuments/Statistical\\_Profiles/Asia/Bangladesh\\_Asia\\_RE\\_SP.pdf](https://www.irena.org/IRENADocuments/Statistical_Profiles/Asia/Bangladesh_Asia_RE_SP.pdf).
- [35] IRENA. Statistical profile Thailand [Online]. Retrieved from the World Wide Web: [https://www.irena.org/IRENADocuments/Statistical\\_Profiles/Asia/Thailand\\_Asia\\_RE\\_SP.pdf](https://www.irena.org/IRENADocuments/Statistical_Profiles/Asia/Thailand_Asia_RE_SP.pdf).
- [36] IndexMundi. Factbook country comparison Bangladesh vs Thailand [Online]. Retrieved from the World Wide Web: <https://www.indexmundi.com/factbook/compare/bangladesh.thailand/energy>.
- [37] EGAT. Thailand electricity generation capacity [Online]. Retrieved from the World Wide Web: [https://www.egat.co.th/index.php?option=com\\_content&view=article&id=80&Itemid=116](https://www.egat.co.th/index.php?option=com_content&view=article&id=80&Itemid=116).



[www.ericjournal.ait.ac.th](http://www.ericjournal.ait.ac.th)

# Carbon Footprint Reduction with the Adoption of the Electricity-Powered Vehicles

Olumide A. Towoju\*

**Abstract** – In the quest to reduce the global carbon footprints, many national governments are adopting the electricity-powered vehicle over conventional vehicles. However, this does not necessarily translate to a reduction of CO<sub>2</sub> emission, as the source of the electricity utilized for the charging/recharging of such vehicles plays a significant contribution to its emission rate. This study looks at selected economies in six different continents and the Middle East to estimate the electric vehicle adoption and CO<sub>2</sub> emission (kg/kWh) benchmark to make them greener than the conventional vehicles. At the current state of the emission from the conventional automobiles, CO<sub>2</sub> emission per kWh of generated electricity is assumed to be below 0.5495 kg for the electric vehicles to be greener, and for a matured synthetic fuel technology below 0.1923 kg. The estimates show that to ensure a transition to the adoption of electricity powered vehicles in Bangladesh and Africa, a shift in electricity generation to clean renewable sources is required.

**Keywords** – CO<sub>2</sub> emission, conventional automobiles, electric vehicles, global warming, greenhouse gas.

## 1. INTRODUCTION

The threat of global due to emission of greenhouse gases continues to be a begging issue waiting for a resolution. CO<sub>2</sub> gas always comes to fore whenever greenhouse gases are mentioned because it is the largest of such gases produced globally after water vapour [1],[2]. The increase in the average global temperature over the pre-industrial era caused by greenhouse gases is a cause of major concern and also is the negative health impact [2]. Global temperatures have increased above 0.6 °C over the past century [2]-[4]. Several activities contribute to the release of CO<sub>2</sub> gas to the environment, among which are land use, waste management, and combustion of carbon-content materials like fossil fuels and plants [3]. Reduction of CO<sub>2</sub> emission is expected to be accomplished by improved efficiency in combustion plants, shift towards alternative energy use, and carbon capture and storage [2],[5],[6], moreover, it is a known fact that life cannot exist without traces of the greenhouse gases [4],[7].

While there has been a continuous improvement in the efficiency of combustion plants, the required level of reduction in the emission of CO<sub>2</sub> gas is yet to be achieved, and attention is now shifted to the use of alternative energy. A direct consequence of which is, many nations are pushing for the adoption of electric vehicles as a means of reducing CO<sub>2</sub> emission in the transportation sector [5,8,9]. The use of alternatives to fossil fuels are also being rigorously pursued in the form of biofuels [10]. The CO<sub>2</sub> emission rate of conventional automobiles, however, can compare favourably with that

of electricity-powered vehicles based on the comparison of the Life Cycle Assessment (LCA) of such vehicles when the generated electricity source is put into consideration [5].

The electric vehicle technology has evolved with time, and some of the hitherto challenges like exorbitant cost price and low drive mileage before a recharge is gradually being overcome [11]. The tail pipe emission from electricity-powered vehicles is zero and this has always been the point of argument for their advocates, however, the electricity generation source is a critical issue which must be considered [5] in the overall evaluation of the emission value of such vehicles. While the generated electricity of some nations can be said to be ‘clean’, this cannot be said for most of the countries. This will result in some countries contributing to the reduction of CO<sub>2</sub> emission with the adoption of electric vehicles, while others will contribute to the increase.

This study, therefore, seeks to develop a benchmark of CO<sub>2</sub> emission from electricity generation that will make the adoption of electricity-powered vehicles environmentally friendlier in comparison to conventional automobiles, and also to determine its suitability in some selected top economies in continents.

## 2. ELECTRICITY GENERATION SOURCES

The global sources of electricity generation are renewable and non-renewable, with the utilization of renewable sources standing at approximately a quarter of the total based on the data available for the year 2018 [12]. Electricity generation from renewables is said to be free of emissions [13], while non-renewables are major contributors to greenhouse gas emission [5]. Although many nations are now investing heavily in electricity generation plants with renewables as an energy source, its installed capacity still hovers around a third of the total [14], and projections for the nearest future look bright putting it at about 50% by the year 2050 [13].

\*Mechanical Engineering Department, Adeleke University, Nigeria.

<sup>1</sup> Corresponding author;  
Tel: + 2348055934207.  
E-mail: [olumidetowo@yahoo.com](mailto:olumidetowo@yahoo.com)



However, it is imperative to note that installed capacity does not translate to generation capacity especially for the case of renewable-powered electricity generation because of the peak and low periods which is their characteristic feature making them have a low value of return on investment for some sources [15],[16].

Renewable energy sources available for electricity generation include hydropower, wind, solar, ocean power, geothermal, and biomass and biofuels, *etc.*, while non-renewable sources are fossil fuels; coal, oil, and natural gas, and nuclear energy [17].

### 3. GREENHOUSE GAS EMISSION CONSIDERATION

The adoption of electric vehicles over the use of conventional automobiles will result into more electricity consumption and demand [5], and hence, it is required to know the energy sources and plants' efficiency to determine the CO<sub>2</sub> emissions from a country's electricity generation sector which will be utilized in powering the electric vehicle. Although the quality of the fuel used in the generation of electricity also plays a huge part in the level of emissions, it can, however, be assumed that the available figures for the year 2018 provided by the United States as depicted in Table 1 still subsists.

**Table 1. CO<sub>2</sub> emission based on energy source.**

Energy Source	CO <sub>2</sub> (kg. /kWh)
Coal	1.003
Natural gas	0.418
Petroleum	0.958

Source: EIA [18].

The CO<sub>2</sub> emission from the renewable sources as mentioned earlier can be said to be zero, and as revealed by the literature [18]. For the United States of America, the fossil fuels powered generated electricity accounted for 99% of the CO<sub>2</sub> emissions despite being only 63% of the total generated electricity. Data exist for the average amount of CO<sub>2</sub> emission for on-the-road conventional automobiles. For petrol as fuel emission is 0.144 kg/km and for diesel 0.109 kg/km [19], and it will not be out of

place to say that biodiesels and alcohols even do better. For any nation to be considered as one whose contribution to global warming is positively oriented with the adoption of the electric vehicle over the conventional vehicle, then her generated electricity must be such that in addition to some other factors when used to power the vehicles it must produce lower CO<sub>2</sub> emission levels. Relying on the data provided, the benchmark adopted for the maximum amount of CO<sub>2</sub> emission per km of road travel for the electric vehicle is put at 0.1 kg/km.

Electric vehicles depend on batteries for their energy storage [5],[20], and the common of such is the Lithium-ion batteries. Lithium-ion batteries derive their functionality from the formation and subsequent reduction of CO<sub>2</sub> emission [21] and the loss of which results in the damage of it. With this point in mind, besides the CO<sub>2</sub> emission produced during the generation of electricity used in powering the electric vehicle, it also emits due to the use of the batteries; the discharge of 1 kg. of Lithium batteries to nature is equivalent to about 12.5 kg. of CO<sub>2</sub> and the production of the batteries is accompanied by the emission of (90-200) kg. of CO<sub>2</sub> per kilogram [22], [23].

In arriving at the CO<sub>2</sub> emission rate of the electricity-powered vehicle, the battery contribution is not factored-in because of the non-inclusion of the emission rate during the process of refining conventional vehicles' fuel. Using the data available from electric vehicle manufacturers like Tesla, Nissan, Hyundai, Ford, the average consumed energy is about 0.182 kWh [5] per kilometer of road travel, and this is the basis for the calculation of the CO<sub>2</sub> emission rate of electric vehicles.

### 4. CASE STUDY OF SELECTED COUNTRIES

To determine the environmental suitability of the adoption of the electric vehicles, the different continents were considered with the selection of the top economies. This was characterized on the CO<sub>2</sub> emission rate per kWh of their generated electricity. The considered countries are depicted in Table 2.

The CO<sub>2</sub> emission per kWh of generated electricity of the studied countries is depicted in Table 3.

**Table 2. Selected countries for studies.**

Africa	Asia	Australia	Europe	*Middle East	North America	South America
Nigeria	China	Australia	Germany	Turkey	USA	Chile
South Africa	Japan	New Zealand	France	Saudi Arabia	Mexico	Argentina
Egypt	India		Italy	Iran	Canada	Brazil
Algeria	South Korea		United Kingdom	Russia	Jamaica	Peru
Morocco	Bangladesh		Spain	UAE	Panama	Uruguay

\*The Middle East is not listed as a continent.

**Table 3. CO<sub>2</sub> emission rate per kWh of electricity generation.**

Country	Key	CO <sub>2</sub> /kWh	Remarks
Nigeria	NG	0.4396	[24],[25]
South Africa	SA	0.9606	[26]
Egypt	EG	0.63	[27]
Algeria	AG	0.6642	[25]
Morocco	MC	0.7312	[25]
China	CH	0.6236	[26]
Japan	JP	0.4916	[26]
India	IN	0.7429	[26]
South Korea	SK	0.517	[26]
Bangladesh	BG	0.6371	[25]
Australia	AS	0.8	[26]
New Zealand	NZ	0.0074	[26]
Germany	GE	0.469	[26]
France	FR	0.047	[26]
Italy	IT	0.327	[26]
United Kingdom	UK	0.2773	[26],[28]
Spain	SP	0.288	[26]
Turkey	TR	0.5434	[26]
Saudi Arabia	SD	0.7176	[26]
Iran	IR	0.571	[29]
Russia	RS	0.4	[30]
UAE	UA	0.4333	[26]
USA	US	0.4759	[26]
Mexico	ME	0.464	[25],[26]
Canada	CA	0.13	[26]
Jamaica	JA	0.7961	[25]
Panama	PA	0.2768	[25]
Chile	CL	0.4086	[25]
Argentina	AR	0.3583	[26]
Brazil	BR	0.0927	[25],[26]
Peru	PE	0.2377	[25]
Uruguay	UG	0.017	[31]

Sources: References [24]-[31].

However, it is important to note that a greater fraction of the studied countries have a quality supply of electricity whose uptime period is close to a hundred percent, but this cannot be said for some countries like Nigeria with only about 54.4%, South Africa with 84.4%, and Bangladesh with 88% [32]. While the electricity supply downtime for Bangladesh and South Africa can be assumed to be minimal, that of for Nigeria one cannot. Nigeria meets the shortfall of her electricity demand through self-generation basically from petroleum-fueled generators which do not pass through the grid [33], and this has to be considered in the determination of the CO<sub>2</sub> emission rate of her available electricity.

The adjusted CO<sub>2</sub> emission rate per kilowatt-hour of available electricity in Nigeria can hence be

determined thus; A generation of about 30,897 GWh [34] of electricity results in an uptime percentage of 54.4 [32], an indication that with all things being equal, a generation of 56,796 GWh will give a 100% quality of supply. It is therefore assumed that the balance of 25,899 GWh of electricity is generated from petroleum. Using the emission rate based on petroleum and factoring in the efficiency ratio of thermal plants to compression ignition engines; 1:1.29 [5], the adjusted CO<sub>2</sub> emission rate for Nigeria electricity is depicted in Table 4.

**Table 4. Adjusted CO<sub>2</sub> emission per kWh.**

Country	Key	CO <sub>2</sub> /kWh
Nigeria	NG	0.5778

Sources: References [24], [25].

The projected amount of CO<sub>2</sub> emission per kilometer of travel of an electric vehicle charged/recharged with generated electricity from the studied selected countries is depicted in Figure 1.

The country that will produce the least emission with the adoption of the electric vehicle is New Zealand followed by Uruguay, while South Africa and Australia will produce the highest rate of emission respectively. The adoption of the electric vehicle over the conventional automobiles will assist in the reduction of greenhouse gas for the countries whose emission rates are below the benchmark line. All the selected studied countries in Europe and South America fall below the benchmark. The benchmark corresponds to a CO<sub>2</sub> emission rate of 0.5494 kg/kWh of generated electricity, which was derived thus;

Average energy consumed per kilometer of road travel = 0.182 kWh [5].

Rate of CO<sub>2</sub> emission expected to make it greener = 0.1 kg/kWh

Corresponding CO<sub>2</sub> emission benchmark (kg/kWh) =  $\frac{0.1}{0.182} = 0.5495$ .

The current energy sources mix for electricity generation in Bangladesh does not favour the adoption of the electric powered vehicle. The adoption will result in more emission of greenhouse gases in comparison with the conventional vehicle as its CO<sub>2</sub> gas emission rate (0.6371 kg/kWh) is in excess of the modeled benchmark. To ensure the sustainability and just transition of energy in the country, it is imperative for the country to shift more to electricity generation from cleaner renewable sources. The country's three coal power plants under construction [35] will in no small way increase is CO<sub>2</sub> gas emission rate per kW of generated electricity. The adoption of the electricity powered vehicle should be suspended until the greenhouse gas emission from her electricity generation falls below the benchmark.

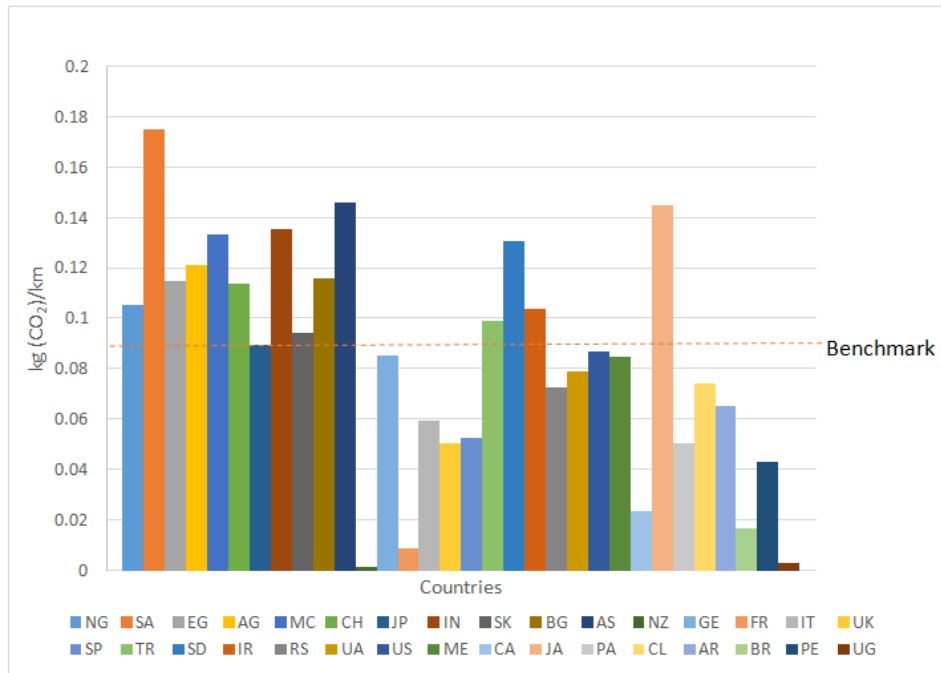

Fig. 1. Estimated CO<sub>2</sub> emission per kilometer of road travel by countries.

With an uptime of 88% in Bangladesh [32], the CO<sub>2</sub> emission rate of the country per kWh can also be adjusted to allow the downtime to be compensated with self-generation. The adjusted value based on average grid value of 13,000 MW [35] is depicted in Table 5.

Table 5. Adjusted CO<sub>2</sub> emission per kWh.

Country	Key	CO <sub>2</sub> /kWh
Bangladesh	BG	0.6590

Sources: Reference [25].

It is, however, to be noted that the use of synthetic fuel will further lower the emission rate benchmark as data shows that its utilization in internal combustion engines results in about a third of the tailpipe emission

of CO<sub>2</sub> gas [5]. The development of synthetic fuel and its wide availability will thus make the adoption of the electric vehicle greener in the hitherto qualified countries according to the depicted model in Figure 1 with emission rates that fall below the benchmark as depicted in Figure 2.

The maturity of the synthetic fuel production and supply will make the adoption of the electric vehicle powered with the current generated electricity greener only five (5) countries according to this study model; New Zealand, France, Canada, Brazil, and Uruguay. At this level, the benchmark electricity generation emission rate per kilowatt-hour for the sole use of electric vehicles to be greener will be 0.1923 kg/kWh.

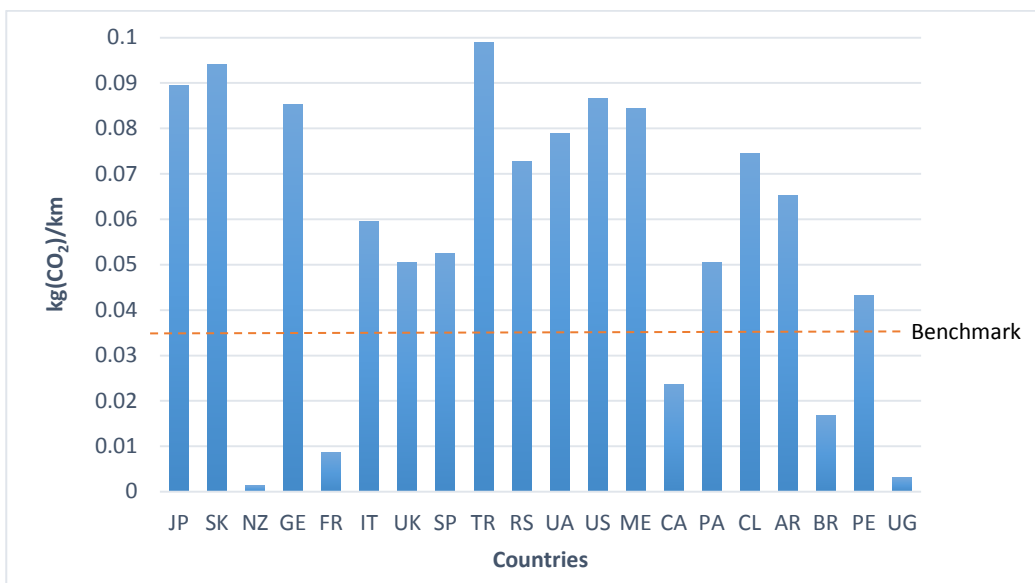

Fig. 2. Estimates based on the use of synthetic fuels.

## 5. CONCLUSION

The top five performing countries in six continents and the Middle East were estimated in this study to determine their contribution to greenhouse gas emission if a switch to electric vehicles from the conventional ones are done. European countries and South American countries will be greener with the adoption of electric vehicles over conventional automobiles, so will be some countries in Asia, North America, the Middle East, and Australia. However, the continent of Africa will contribute more to global warming with a switch from conventional vehicles to electric vehicles. This is due to no other fact that the major players in the continent rely on non-renewable sources for the generation of the bulk of their electricity. Bangladesh needs to shift to electricity generation to cleaner renewable sources to ensure to if electricity powered vehicles are going to be used.

The estimates also show that only five countries: New Zealand, France, Canada, Brazil, and Uruguay will be more green if the synthetic fuel technology should get matured at the present electricity generation fuel mix. The greener the electricity generation becomes, the greener will be the electric vehicle and synthetic fuel.

## REFERENCES

- [1] IPCC. Summary for policymakers. In: O. Edenhofer, R. Pichs-Madruga, Y. Sokona, E. Farahani, S. Kadner, K. Seyboth, et al., editors. Climate change 2014: mitigation of climate change. Contribution of working group III to the fifth assessment report of the intergovernmental panel on climate change. Cambridge, United Kingdom and New York, NY, USA: Cambridge University Press; 2014.
- [2] Tan Z., 2014. *Air pollution and greenhouse gases. Green Energy and Technology*, Springer.
- [3] Aizebeokhai A.P., 2009. Global warming and climate change: Realities uncertainties and measures. *Int J Phys Sci.* 4(13): 868–79.
- [4] Hannah R. and R. Max, 2019. CO<sub>2</sub> and other greenhouse gas emissions. Published online at *OurWorldInData.org*. Retrieved April 15, 2019 from the World Wide Web: <https://ourworldindata.org/co2-and-other-greenhouse-gas-emissions>.
- [5] Towoju O.A. and F.A. Ishola, 2020. A case for the internal combustion engine powered vehicle. *Energy Reports* 6(2): 315-321.
- [6] Towoju O.A., and A. Dare, 2016. Di-methyl ether (DME) as a substitute for diesel fuel in compression ignition engines. *Int J Adv Res Eng Manage* 2(5): 39–47.
- [7] Michaelides E.E., 2012. *Alternative energy sources. Green Energy and Technology*, Springer.
- [8] Wang N., Tang L., Zhang W., and Guo J., 2019. How to face the challenges caused by the abolishment of subsidies for electric vehicles in China? *Energy* 166: 359–72. Retrieved from the World Wide Web: <http://dx.doi.org/10.1016/j.energy.2018.10.006>.
- [9] Link C., Raich U., Sammer G., and Stark J., 2012. Modelling demand for electric cars – A methodical approach. *Procedia - Social and Behavioral Sciences* 48: 1958 – 1970.
- [10] Towoju O.A., and S.O. Jekayinfa, 2019. Compression ignition engine performance as a function of the fuel properties. *Journal of Engineering Sciences* 6(1): G1-G5. DOI: 10.21272/jes.2019.6(1).g1.
- [11] Lambert F., 2016. Breakdown of raw materials in Tesla’s batteries and possible bottlenecks. Retrieved April 134, 2019 from the World Wide Web: <https://electrek.co/2016/11/01/breakdown-raw-materials-tesla-batteries-possible-bottleneck/>.
- [12] The World Bank. Renewable Electricity Output (% of Total Electricity Output). Retrieved March 12, 2020 from the World Wide Web: <https://data.worldbank.org/indicator/EG.ELC.RNE.W.ZS>.
- [13] Islam M.A., Hasanuzzaman M., Rahim N.A., Nahar A., and Hosenuzzaman M., 2014. Global renewable energy-based electricity generation and smart grid system for energy security. *The Scientific World Journal*, Article ID 197136. doi.org/10.1155/2014/197136.
- [14] IRENA, 2019. *Renewable Energy Now Accounts for A Third of Global Power Capacity*. Retrieved from the World Wide Web: <https://www.power-technology.com/news/irena-report-renewable-energy/>.
- [15] Breeze P., 2016. Chapter 2 - The Wind Energy Resource. *Wind Power Generation*, 9-17. doi.org/10.1016/B978-0-12-804038-6.00002-5.
- [16] Jônatas da Mata F.C., Mesquita A.Z., and Neto R.O., 2017. Comparison of the performance, advantages and disadvantages of nuclear power generation compared to other clean sources of electricity. *International Nuclear Atlantic Conference – INAC*.
- [17] Chen J., 2019. Nonrenewable resources. Investopedia. Retrieved from the World Wide Web: <https://www.investopedia.com/terms/n/nonrenewableresource.asp>.
- [18] US Energy Information Agency. 2020. How much carbon dioxide is produced per kilowatthour of U.S. electricity generation? [Online], Retrieved June 17, 2020 from the World Wide Web: <https://www.eia.gov/tools/faqs/faq.php?id=74&t=1>.
- [19] IAV GmbH. 2017. Combustion engines with CO<sub>2</sub> – avoiding fuel. [Online], Retrieved April 4, 2019 from World Wide Web: <https://www.iav.com/us/automotion->



- [magazine/automotion-2017-issue-02/combustion-engines-co2-avoiding-fuel?r=en&n=14058](https://www.researchgate.net/publication/318111111/magazine/automotion-2017-issue-02/combustion-engines-co2-avoiding-fuel?r=en&n=14058).
- [20] Zeinab R., Johan J., and Jan B., 2015. Advances in consumer electric vehicle adoption research: A review and research agenda. *Transp Res D*. 34: 122–36.
- [21] Sloop S.E., Kerr J.B., and Kinoshita K., 2003. The role of li-ion battery electrolyte reactivity in performance decline and self-discharge. *J Power Sources* 119–121, 330–7.
- [22] Soodabeh S. and A. Mohammed, 2013. Concerns on the growing use of lithium: The pros and cons. *Iranian Red Crescent Med J* 15(8): 629–32.
- [23] Wolfram P. and T. Wiedmann, 2017. Electrifying Australian transport: Hybrid life cycle analysis of a transition to electric light-duty vehicles and renewable electricity. *Appl Energy* 206(2017): 531–40.
- [24] Sam-Amobi C., Ekechukwu O.V., and Chukwuali C.B., 2019. A preliminary assessment of the energy related carbon emissions associated with hotels in Enugu metropolis Nigeria. *International Journal of Science and Technology (STECH), Ethiopia* 8(2): 19 – 30.
- [25] Brander M., Sood A., Wylie C., Haughton A., and Lovell J., 2011. Electricity-specific emission factors for grid electricity. *Ecometrica* 1-22. Retrieved from the World Wide Web: <https://ecometrica.com/assets/Electricity-specific-emission-factors-for-grid-electricity.pdf>.
- [26] Carbon footprints. 2019. Grid electricity emission factors. [Online], Retrieved June 18, 2020 from the World Wide Web: [https://www.carbonfootprint.com/docs/2019\\_06\\_e\\_missions\\_factors\\_sources\\_for\\_2019\\_electricity.pdf](https://www.carbonfootprint.com/docs/2019_06_e_missions_factors_sources_for_2019_electricity.pdf)
- [27] Abdallah L. and T. El-Shennawy, 2017. Evaluation of CO<sub>2</sub> emissions from electricity generation in Egypt: Present status and projections to 2030. In Proceedings of the 1<sup>st</sup> International Conference of Chemical, Energy and Environmental Engineering ICCEEE.
- [28] Loughran J., 2017. Carbon emissions associated with UK's electricity generation have halved since 2012. *Eng Technol*. Retrieved May 1, 2019 from the World Wide Web: <https://eandt.theiet.org/content/articles/2017/11/carbon-emissions-associated-with-uk-s-electricity-generation-have-halvedsince-2012/>.
- [29] Noorpoor A.R. and S.N. Kudahi, 2015. CO<sub>2</sub> emissions from Iran's power sector and analysis of the influencing factors using the stochastic impacts by regression on population, affluence and technology (STIRPAT) model. *Carbon Management* 6(3-4): 101-116. DOI: 10.1080/17583004.2015.1090317).
- [30] Climate Transparency. 2016. Brown to green: G20 transition to a low carbon economy. [Online], Retrieved on June 18, 2020 from World Wide Web: <http://www.climate-transparency.org/wp-content/uploads/2016/08/Russia-2016.pdf>
- [31] Sierra W., 2016. Uruguay: Revolution rather than energy transition? *Heinrich Boll Stiftung*. Retrieved June 18, 2020 from the World Wide Web: <https://us.boell.org/en/2016/06/20/uruguay-revolution-rather-energy-transition>.
- [32] Index Mundi. 2019. Access to electricity (% of population) – country ranking. Retrieved on June 19, 2020 from the World Wide Web: <https://www.indexmundi.com/facts/indicators/EG.ELC.ACCS.ZS/rankings>.
- [33] Towoju O.A., Ishola F.A., and Elomien E. Decentralized electricity generation can revive Nigeria dying critical sectors.
- [34] Wikipedia. List of countries by electricity generation. [Online], Retrieved on July 25, 2020 from the World Wide Web: [https://en.wikipedia.org/wiki/List\\_of\\_countries\\_by\\_electricity\\_production](https://en.wikipedia.org/wiki/List_of_countries_by_electricity_production).
- [35] Fairley P. 2020. Bangladesh scrambles to deliver electricity to its 160 million residents in 2021. *IEEE Spectrum*, [Online serial] Retrieved on July 26, 2020 from the World Wide Web: [spectrum.ieee.org](https://spectrum.ieee.org).



[www.ericjournal.ait.ac.th](http://www.ericjournal.ait.ac.th)

# International Cereal Trade of Bangladesh: Implications for Virtual Land, Water, and GHG Emissions from Agriculture

Parmeshwar Udmale\*<sup>+</sup>, Indrajit Pal<sup>+</sup><sup>1</sup>, Sylvia Szabo\*, and Malay Pramanik\*

**Abstract** – The study aims to get insights into virtual land, water flows from producers' perspectives for cereal crops and trade in Bangladesh and provides insights into the carbon emissions from agriculture. For this purpose, FAO's cereals area, production and yield, food balance sheets, detailed trade matrix, GHG emissions, and population data for the year 2014-17 were used. Cereal water footprints data were obtained from the secondary literature. The study finds that 8% of domestic cereal supply (70% wheat, 17% maize, and 2% rice and related products) was imported through international trade. The annual average virtual cropland area and water imported through trade of 6.9 million tonnes of the three cereal crops (excluding products) were 2.1 million ha and 14 billion m<sup>3</sup>, respectively, during 2014-17. Bangladesh would need additional 2.81 million ha land and 12 billion m<sup>3</sup> water to be cereal self-sufficient. Energy used in agriculture, including mechanization and irrigation, adds to GHG emissions, and there is potential to use renewable energy sources to reduce the GHG emissions from agriculture. An integrated management of water, energy, and carbon should be considered as one of the strategies to reduce GHG emissions from agriculture.

**Keywords** – Bangladesh, carbon trade, greenhouse gases, international crop trade, water-energy-food nexus

## 1. INTRODUCTION

Greenhouse gas (GHG) emissions and water consumption in a globalized world are becoming important indicators for policy and decision making [1]. With increasing population and economic development, water use in domestic, industrial, and agricultural sectors has increased, in turn accelerating energy consumption in the treatment and transport of water. Energy is used in various stages of water use, such as abstraction, conveyance, water treatment, and treatment of sewage water after water is used to sustain the ecosystem. So far, agriculture consuming the highest amount of water, which is about 70% of water extractions from aquifers, lakes, rivers, and ponds, even in an unsustainable way [2]. The Food and Agriculture Organization (FAO) [3] projected that the use of irrigated and rainfed agricultural water consumption by 2050 would increase by 19%. However, this could be far higher if agricultural production efficiency and crop yields do not increase dramatically. This abstraction exceeds local availability and accessibility of renewable water, and irrigation depletes the groundwater supplies [4].

Pre-industrial societies used agriculture as an important consumer of energy and practically as the only cause of mechanical power until the Industrial

Revolution [5]. Mechanization, chemical fertilizer, synthetic pesticides, and high-yielding seeds are primary causes for the increase in intensive energy usage in agriculture systems. Energy use in farming activity is accounted for in the building and energy and transport sectors included in the UNFCCC framework [6]. The energy transition challenge calls for re-recognizing agriculture as a source of energy, which can deliver food and bioenergy to society as an alternative to fossil fuels. In agriculture, energy consumption is increasing because of the increasing, the rapid growth of population, limited supply of arable lands, and improved living standards [7]. However, recent agriculture activity relies heavily on fossil fuel themselves, and so is far from considering a renewable energy system [8]-[10]. The study of agriculture systems' aspects of land, water, and energy metabolism can provide insights into systemic energy surpluses or deficits and the dynamic connections between productivity and energy inputs.

Agriculture is the key economic sector, which is responsible for crop and livestock activities for primary food production. Since 1970 human population has been rising from 3.7 billion to over 7.0 billion [11], and higher use followed by a transition in diet to more animal products has meant more than doubling agriculture production [12]. As such, it contributes significantly to global warming and climate change. Carbon dioxide (CO<sub>2</sub>), methane (CH<sub>4</sub>), Nitrous oxide (N<sub>2</sub>O), Fluorinated gases (F-gases) are the key GHG emitted by anthropogenic activities. CO<sub>2</sub> is mainly emitted from the burning of fossil fuels and industrial processes. Agriculture activities, including deforestation, soil management, cultivation, fertilizers, energy use, agricultural waste management, and crop burning, as well as livestock and manure management, can emit CO<sub>2</sub>, CH<sub>4</sub>, and N<sub>2</sub>O [13], [14]. The current estimate of

\*Department of Development and Sustainability, Asian Institute of Technology, P.O. Box 4, Klong Luang, Pathumthani 12120, Thailand.

<sup>+</sup> Disaster Preparedness, Mitigation, and Management, Asian Institute of Technology, P.O. Box 4, Klong Luang, Pathumthani 12120, Thailand.

<sup>1</sup> Corresponding author;  
Tel: + 66-2-524-6428.  
E-mail: [indrajit-pal@ait.ac.th](mailto:indrajit-pal@ait.ac.th).

23 % of total anthropogenic GHG emissions comes from agricultural growth, forestry, and land-use conversion [13].

Recently it has, however, been seen that world agriculture in terms of GHG emissions is becoming more efficient. Emissions are decoupled increasingly from production as production has proliferated. In 2007, the average global carbon footprint per unit livestock and the crop produced were declined by 44% and 39% than 1970, respectively [13, 15]. According to the Intergovernmental Panel for Climate Change (IPCC), agricultural production was estimated to be 10–12% of the world anthropogenic GHG in 2005, while direct non-CO<sub>2</sub> GHG emissions from farming amounted to 56% of the world non-CO<sub>2</sub> [13]. These emissions do not include other food-related emissions directly and indirectly but originated outside of the farm gate. For example, agriculture is linked to land use and land cover (LULC) changes, i.e., peatland drainage and deforestation, which generate GHG emissions similar to those generated by the farm activities globally.

The change in frequency and magnitude of rainfall is likely to cause a change in global water distribution and food production systems. This will increase not only the energy needs for the transportation of water but also food, mainly through international trade [16]. About 23% of food consumed is traded internationally [17]. Therefore, the concept of virtual land, water, and GHG (expressed in CO<sub>2</sub> equivalent) termed as carbon footprint has evolved [18], [19]. Land and water footprint are defined as the land and water embedded in a product throughout the process of production, respectively.

Similarly, carbon footprint is the total GHG emissions caused by a product, expressed as CO<sub>2</sub> equivalent. The virtual land, water, and carbon emissions are defined as the amount of land, water, and carbon embedded in the traded products between two regions. Food traded internationally could significantly reduce the pressure on the local land, water, and energy used for agricultural systems. GHG emissions could be transferred from one region to another in the form of international trade of goods and services, agriculture crops, and livestock. Peters *et al.* [20] reports major source of carbon flows through trade were fossil fuels (37% of global emissions), CO<sub>2</sub> embodied in traded goods and services (22% of global emissions), crops (31% of total harvested crop carbon), petroleum-based products (50% of their total production), harvested wood products (harvested wood products (40% of total round wood extraction), and livestock products (22% of total livestock carbon) in 2004.

Identifying the land, water, carbon footprints (energy) of a crop is an essential component of sustainable agriculture, reducing the resource use per unit crop production [21]. Developing countries have put a strong emphasis on decreasing GHG emissions from agriculture sectors in their mitigation. Most countries with Intended Nationally Determined

Contributions (INDC) do not specify the measures intended to achieve their broader emission targets. For example, measures adopted to decrease emission from enteric fermentation, manure management, or managed soil or livestock or cropland-based management contributions [22] or adoption of improved irrigation techniques and clean energy or offsetting the land, water and carbon by importing food crops from other countries having surplus production as highlighted in [16]. In this context, the present study aims to assess virtual land and water flows through cereal crop imports in Bangladesh based on resources used per unit cereal crop (wheat, rice, and maize) and trade volume component of the food (cereal) balance. Besides, the present study quantifies the scenario of Bangladesh being cereal crop self-sufficient and its implications to the country's agricultural land, water, and potential GHG emissions from agriculture.

## 2. DATA AND METHODS

For cereals area, production and yield, food balance sheets, detailed trade matrix, population data are downloaded from FAOSTAT [12]. The green, blue, and grey water footprints for cereal crops (wheat, rice, and maize) per tonne at sub-national levels are obtained from Mekonnen and Hoekstra [23]. The blue water footprint is the volume of surface and groundwater consumed in the form of evaporation to produce crops; the green water footprint is the rainwater consumed by a crop. The grey water footprint of a product is defined as the volume of freshwater that is required to assimilate load of pollutants based on existing ambient water quality standards [24]. The subnational scale water footprints are averaged to obtain national scale water footprints. Some of the countries do not have water footprint data. Therefore, the global average water footprints are used in the analysis of import volumes from those countries. The total agricultural greenhouse gas emission (GHGs) expressed in CO<sub>2</sub> equivalent (CO<sub>2</sub>e) is obtained from FAOSTAT [12]. Virtual land and water are calculated from producers' perspectives based on resources used for per unit crop production and crop trade volume based on detailed trade matrix using the following equations:

$$\text{Virtual land (ha)} = \frac{\text{Volume of crop traded (tonnes)}}{\text{Crop productivity (tonnes per ha) of partner country}} \quad (1)$$

$$\text{Virtual water (m}^3\text{)} = \text{Volume of crop traded (tonnes)} \times \text{Water footprint (m}^3\text{/tonnes)} \quad (2)$$

The average world factor to convert paddy rice (FAO Item Code 0027) to husked rice (FAO Item Code 28(a)) is 0.77 (in the range of 0.70 to 0.85) and to milled rice (FAO Item Code 0031(b)) is 0.67 (in the range of 0.60 to 0.70) [25]. The detailed trade data available in milled rice volume is converted to paddy rice by using a

1/0.67 factor. The average area harvested and the average yield of major import partners of Bangladesh are used for the countries, which had missing data. The virtual land and water flows imported through the wheat, rice, and maize are analyzed considering the average of 2014-2017 area harvested, production, yield, and import data as the latest trade data were available till 2017. Bangladesh has a relatively less volume of export of cereal crops compared to its import. Hence study primarily focuses on the import component of national food (cereal) balance. The area harvested, yield, and water footprints for wheat, rice, and maize in Bangladesh context are used to estimate land and water needs based on the country's cereal self-sufficiency scenario. The GHG emissions from agriculture are analyzed based on FAO data. Irrigated area, number and type of irrigation pumps, and energy consumption in agriculture are obtained from Mottaleb *et al.* [26] and FAOSTAT [12]. Potential opportunities to reduce GHG from agriculture are discussed with reference to literature.

### 3. RESULTS

#### 3.1 Cereals Area, Production, and Yield

In Bangladesh, about 99.7% of the total harvested area for cereals (12.66 million ha) in 2018 is for rice (here, rice=paddy), wheat, and maize. Like many other south and south-east Asian countries, rice is the staple food in Bangladesh. Rice accounts for 70-80% of the total cropped area of the country. In 1961, rice area harvested, production, and yield were 8.5 million ha, 14.4 million tonnes, and 1.7 tonnes per ha, respectively, which increased by 1.4, 3.9, and 2.8 folds, respectively, over 1961-2018 (Figure 1b). In 2018, the rice area harvested

was 11.9 million ha, with a total production of 56.4 million tonnes (almost 93% of total cereal production in the country). Rice plays a significant role in securing countries' food supply and sustaining the agricultural economy. Rice crop is grown in three seasons a year in Bangladesh. It has about 80% share in the total irrigated area of the country. Wheat is the second most-produced cereal crop in Bangladesh. However, its area harvested and production is less than rice. The wheat area harvested and production increased from 0.05 to 0.35 million ha, and 0.03 to 1.1 million tonnes, respectively, over 1961-2018 (Figure 1c). Similarly, maize area harvested and production have increased from 9 to 400 thousand ha, and 7 thousand tonnes to 3.3 million tonnes, respectively, over 1961-2018 (Figure 1d).

While considering the country's cereal balance, the average domestic cereal supply was 374 kg/capita/year during 2014-17, of which 92% was domestic production and 8% imported through international trade. The average domestic cereal supply of rice (including rice products) was 323 kg/capita/year during 2014-17, which share 86% of the domestic cereal supply. Similarly, average domestic supplies of wheat (including wheat products) and maize (including maize products) were 32 and 19 kg/capita/year during 2014-17, respectively. Out of these domestic supplies, about 70% and 17% of domestic wheat (including wheat products) and maize (including maize products) supplies, respectively, were imported through international trade. Only 2% of domestic rice (including rice products) was imported through international trade (about 1.3 million tonnes). With the increasing trend of cereal area, production, and yield, the inputs to agriculture such as mechanization, fertilizer applications, and irrigation needs are increasing water, energy, and carbon footprints from agriculture.

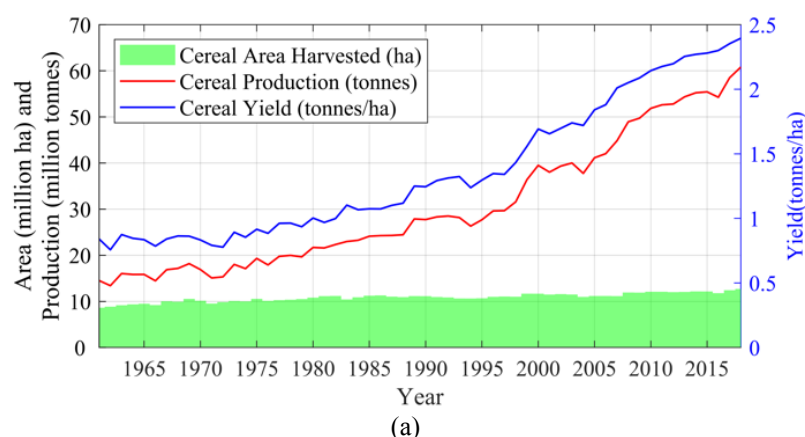



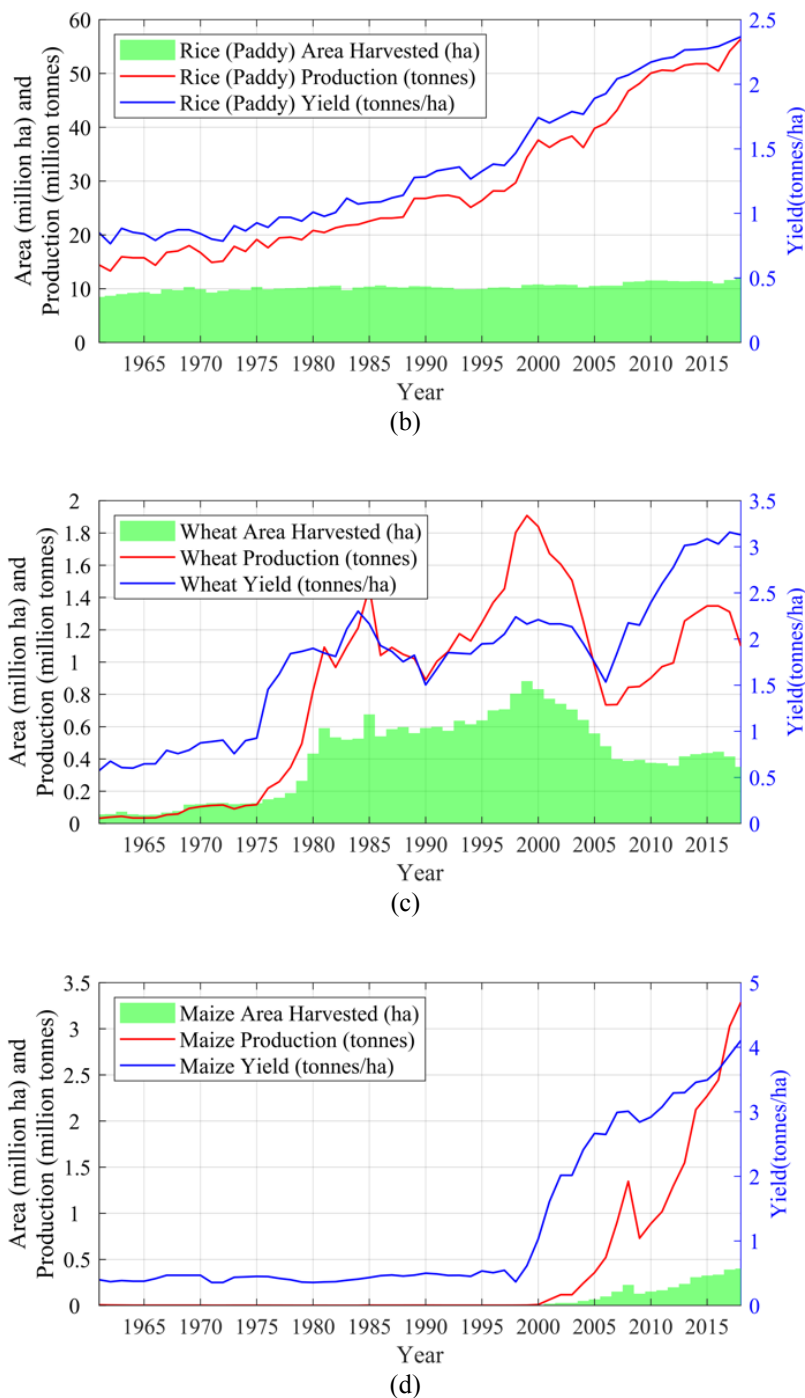

**Fig. 1. Trends in area harvested, production and yield for (a) Total Cereals (b) Rice, (c) Wheat, and (d) Maize crops in Bangladesh from 1961 to 2018.**

### 3.2 International Cereal Trade: Virtual Land and Water Import

The global average cereal water footprint (including green, blue, and grey) is 1644 m<sup>3</sup>/tonne. The global average water footprints of rice (paddy), wheat, and maize are 1809, 1469, 1423 m<sup>3</sup>/tonne, respectively. In Bangladesh, the average water footprints of rice (paddy), wheat, and maize are 1672, 1827, and 1222, respectively. FAO detailed trade matrix data for rice (milled), wheat, and maize were used for analyzing Bangladesh's international trade with major partner countries across

the world. The rice milled was converted to rice paddy (FAO Item Code 0027) using (1/0.67) conversion factor.

Annually, Bangladesh imported 1.3 million tonnes of rice (paddy) with 0.36 million ha virtual land and 2.87 billion m<sup>3</sup> of virtual water import through rice during 2014-17. India, Thailand, and Vietnam were the top rice exporters in Bangladesh, with 99% of rice imported from these three countries (Figure 2). Wheat was the largest imported cereal with an average annual import of 4.82 million tonnes. About 96% of Bangladesh's wheat import was from Ukraine, Russian

Federation, Canada, India, Argentina, Australia, and the USA during 2014-17. Annually, Bangladesh imported 1.53 million ha virtual land and 9.77 billion m<sup>3</sup> of virtual water through wheat import (Figure 3) during 2014-17. Bangladesh imported 0.81 million tonnes maize/year during 2014-17. About 91% of maize import was from Brazil, India, and the USA. The country imported 0.17 million ha virtual land and 1.35 billion m<sup>3</sup> virtual water through maize import (Figure 4). During 2014-17, the annual average virtual cropland harvested area and water

imported through trade (import) of 6.9 million tonnes of the three cereal (excluding products) crops were 2.1 million ha and 14 billion m<sup>3</sup>, respectively. In case of the scenario of Self-sufficient Bangladesh in cereals (rice, wheat, and maize), the country will need an additional 2.81 million ha land for cereal crops and 12 billion m<sup>3</sup> (blue, green, and grey) water, which will increase the GHG emissions from agricultural activities such as mechanization and irrigation.

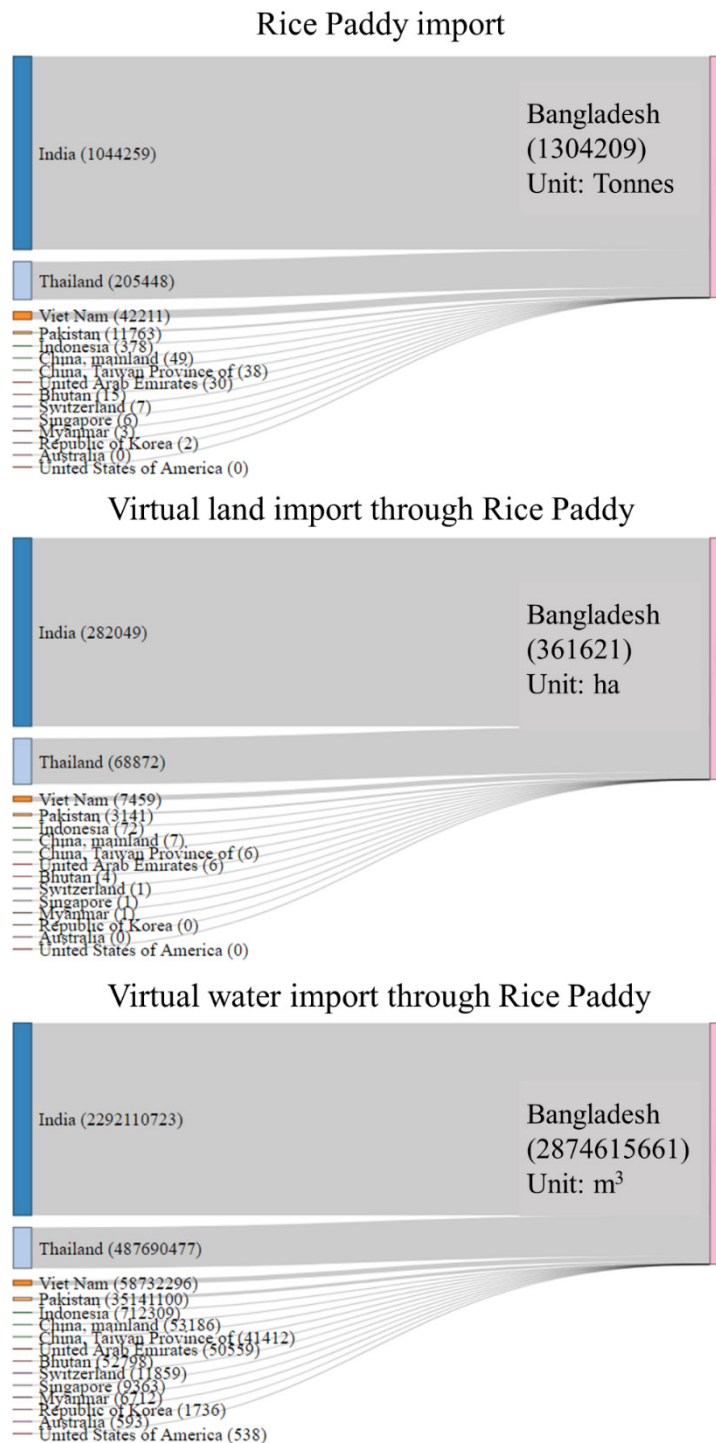

**Fig. 2. Annual average Rice (Paddy) import, virtual land, and water flow through rice import in Bangladesh from 2014 to 2017.**

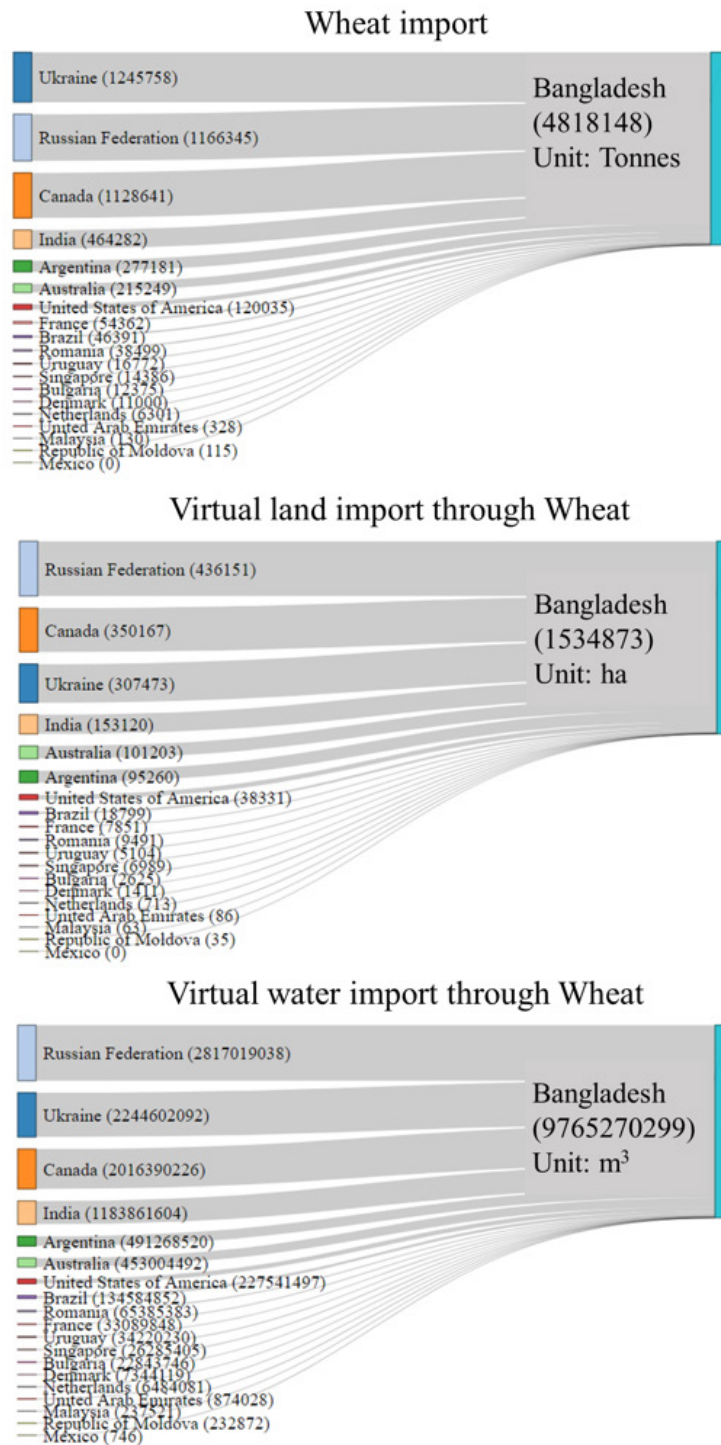

Fig. 3. Annual average Wheat import, virtual land, and water flow through rice import in Bangladesh from 2014 to 2017.

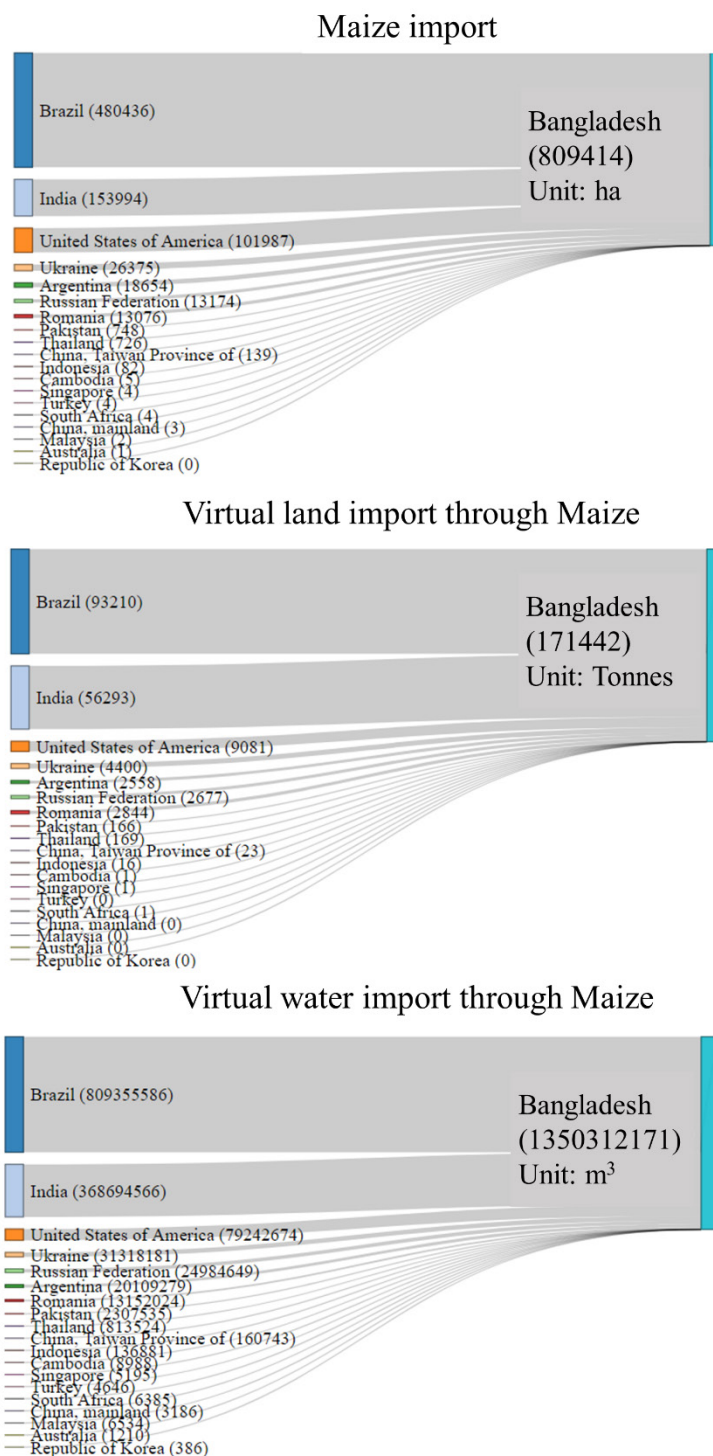

Fig. 4. Annual average maize import, virtual land, and water flow through rice import in Bangladesh from 2014 to 2017.

### 3.3 Energy Consumption and Carbon Emission from Agriculture

With an increasing trend in the crop area and yield, Bangladesh's GHG emissions from agriculture have increased from 58 million tonnes CO<sub>2</sub>e (Mt CO<sub>2</sub>e) in 1990 to 77 Mt CO<sub>2</sub>e in 2017. Rice is the major crop grown in Bangladesh, with 93.8% share in total cereal area harvested in 2018. Rice is the major contributor of GHG emissions from agriculture. A study by Kritee *et al.* [27] reports that about one-half of all crop-related

global greenhouse gas emissions in agriculture comes from rice cultivation. Enteric fermentation (methane emissions from ruminant animals) contributed 24.4 Mt CO<sub>2</sub>e, and rice cultivation contributed 23.5 Mt CO<sub>2</sub>e to GHG emissions from agriculture, which is 32% and 30% of total emissions from agriculture in 2017, respectively (Figure 5a). Manure left on pasture and synthetic fertilizers contribute 10 Mt CO<sub>2</sub>e and 8 Mt CO<sub>2</sub>e to GHG emissions from agriculture in 2017, respectively.



Apart from agricultural carbon emissions from enteric fermentation, rice cultivation, manure, and fertilizers, energy used in agricultural mechanization and irrigation, mainly from fossil fuels, also contributes to carbon emissions. Bangladesh's irrigated land has increased from 1.52 million ha in 1982-83 to 5.5 million ha in 2015-16 (Figure 5b). A study by Zou *et al.* [28] estimates GHG emissions from energy used in irrigation, which includes water pumping and conveyance, accounts for 50 to 70% of total emissions from energy use in the agriculture sector. In 2015-16, Bangladesh had 1.72 million irrigation pumps (includes seep tube wells, shallow tube wells, and low lift pumps). The number of irrigation pumps shows a 12-folds increase from 1982-83 to 2015-16. With increased irrigated area and number of irrigation pumps, the energy consumption in agriculture has increased from 4550 terajoules in 1982 to 53668 terajoules in 2012 (Figure 5c).

The proliferation of the number of shallow tube wells has increased energy consumption in irrigation.

The majority of irrigation pumps use gas-diesel oil and electricity for the operation of irrigation pumps, causing an increase in carbon emissions. Figure 5d shows that GHG emissions from energy consumption in agriculture. Emissions from gas-diesel oil use in agriculture, mostly for irrigation, have increased from 1.27 Mt CO<sub>2</sub>e in 1995 to 3.83 Mt CO<sub>2</sub>e in 2012 (about 3-folds increase). The increased need for agricultural mechanization and irrigation could increase the future energy consumption contributing to an upsurge in GHG emissions. Currently, GHG emissions are measured at producers' perspectives; hence the carbon embodied in import is not counted at national level emissions. However, more growth in the domestic agricultural area and crop production could add more pressure on land, water, energy use, and an increase in GHG emissions. In the scenario of Bangladesh-being cereal self-sufficient, the additional land, area harvested, water, and irrigation needs could add to the National GHG emissions.

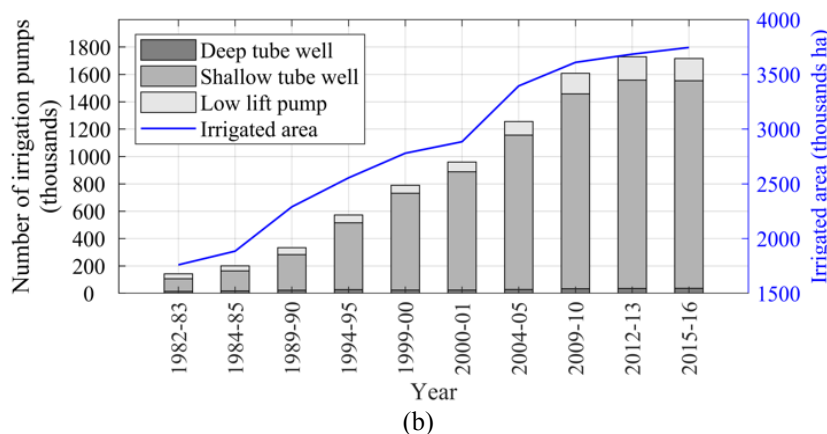
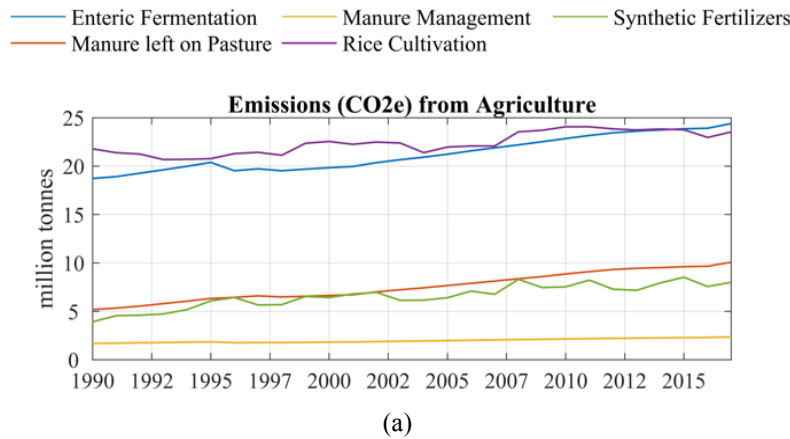

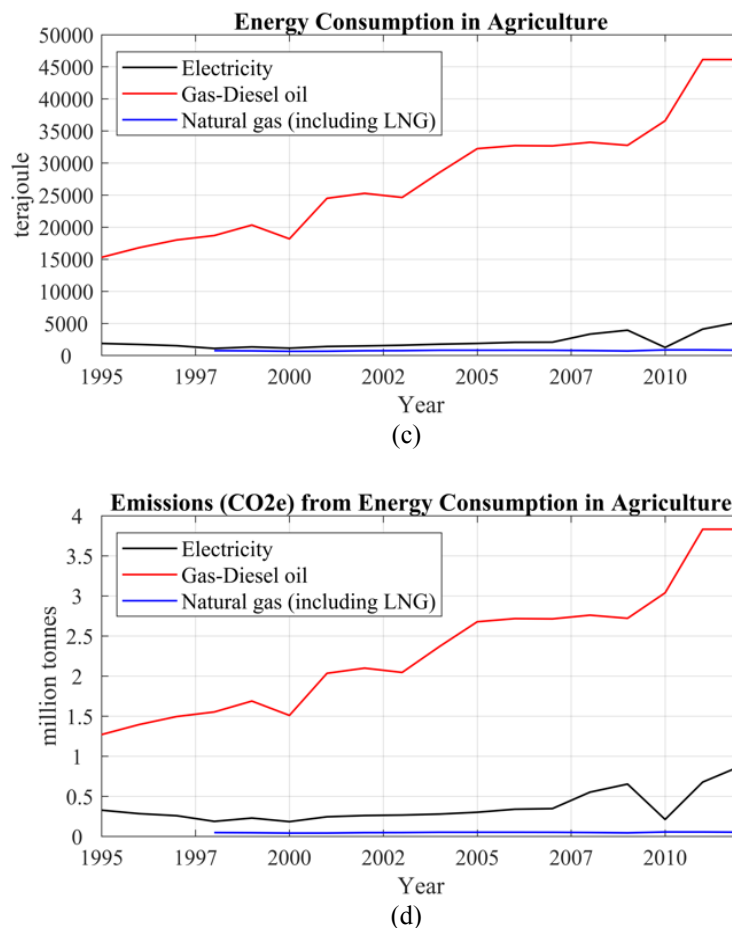

**Fig. 5.** Trend in (a) carbon emission from agriculture (1990 to 2017), (b) the number of irrigation pumps and area irrigated (1982-83 to 2015-16), (c) energy consumption in agriculture (1995 to 2012), and (d) carbon emissions from energy consumption in agriculture (1995 to 2012).

#### 4. DISCUSSION

The study analyses the virtual land and water flows through the import of cereal crops in Bangladesh. The study finds that a considerable amount of virtual land and water is being imported in Bangladesh from major trade partner countries, offsetting Bangladesh's GHG emissions at the national level. The country will need additional 2.81 million ha land for cereal crops and additional 12 billion m<sup>3</sup> (blue, green, and grey) water for being food self-sufficient, in turn, increasing the GHG emissions from agricultural activities under the current practices, including mechanization and irrigation. Increasing crop demand in the country will pose extra pressure on local resources to produce more crop per unit resource use. The more resource use (land, water, and energy) under the current practices will finally contribute to the GHG emissions. IPCC [13] lists major mitigation options within agriculture, forestry, and other land use as conserving existing carbon pools in soils or vegetation, enhancing the uptake of carbon in terrestrial reservoirs sequestration), and reducing CO<sub>2</sub> emissions by substitution of biological products for fossil fuels. Demand-side options to reduce carbon emissions within agriculture, forestry, and other land use are lifestyle

changes, reducing food wastes and losses, changes in diet, and changes in consumption of wood consumption. Adjusting methods of agricultural land and crop management, livestock, and manure management can reduce the GHG emissions from the agricultural sector.

Mitigation and Low Carbon Development programme T5P5 of Bangladesh Climate Change Strategy and Action Plan 2008 (BCCSAP) [29] aims to increase the productivity of agricultural land and lower GHG emissions from agriculture. One of the major GHG emissions, mainly methane (CH<sub>4</sub>), comes from the continuously flooded rice cultivation. The diesel engines used for rice flood irrigation purposes emit CO<sub>2</sub>. However, it has been found that alternate wetting and drying, and furrow irrigation systems significantly reduce the water use in rice irrigation systems and increasing productivity [30]. Alternate drying and wetting irrigation technique or furrow irrigation and decreased amount of irrigation water could reduce fuel or energy consumption in rice crop systems, decreasing GHG emissions. Bangladesh INDC, in its possible conditional action-based contributions, targets a decrease in GHG emissions from rice crops by scaling up the rice cultivation using alternate wetting and drying irrigation in 20% rice cropped area [31]. A study by Ali

et al. [32] in Bangladesh has reported that intermittent irrigation treatment in rice (paddy) fields reduce methane emission by 34 kg/ha as compared to emissions from continuous irrigation treatments (124 kg/ha).

In contrast, it was reported that nitrous oxide emissions from rice (paddy) fields increased to 0.98 kg/ha under intermittent irrigation treatment compared to continuous irrigation treatment (0.55 kg/ha). A study by Kritee et al. [27] reported that the Indian subcontinent's nitrous oxide emissions from intermittent irrigation treatment of rice (paddy) fields could be 30-45 times higher than reported under continuous flooding. Therefore, careful consideration should be given for promoting emission-reducing irrigation techniques through scientific research.

A decrease in inorganic fertilizers used in agriculture could also decrease GHG emissions. Bangladesh INDC targets reducing GHG emissions from fertilizers by a 35% increase in the use of organic fertilizers compared to the business as usual (baseline year 2011) scenario [31]. Bangladesh INDC, in its possible conditional action-based contributions in agriculture (non-energy related sector), emphasizes on decreasing agriculture dependence on draft cattle by 50% and increasing the mechanization of agriculture, which may reduce the GHG emissions from agriculture. However, increased fuel consumption in farm mechanization will add to the GHG emissions. Integrated management of land, water, nitrogen, and carbon can reduce GHG emissions from agriculture by 90% [27], mainly from rice cultivation, fertilizers use, and energy consumption for irrigation. Further country-specific potential to reduce agricultural emissions by adopting a life cycle assessment approach is needed.

In Bangladesh Delta Plan 2100 [33], Strategies for Cross-cutting Issues include - agriculture, food security, nutrition and livelihoods, and renewable energy policy measures – aiming to reduce GHG emissions from agriculture. It includes measures to lower emissions from agriculture land, at least 30% energy use from renewable sources by 2041 (about 10% by 2020), use solar energy sources for surface and groundwater irrigation, explores the potential of hydropower or tidal wave energy generation. Changing from fossil fuel to renewable energy use in agriculture and related activities like solar, hydropower, and wind energy could reduce the net emissions from agriculture. In this case, it would be interesting to explore the scenario of Bangladesh being self-sufficient and how much additional land, water, and GHG emissions could be reduced by adopting measures to decrease the emissions from agriculture.

## 5. SUMMARY AND CONCLUSIONS

The present study finds that 8% of Bangladesh's domestic cereal supply (70% wheat, 17% maize, and 2% rice and related products) was imported through international trade. The annual average virtual cropland

harvested area and water imported through the trade of 6.9 million tonnes of the three cereal (excluding products) crops were 2.1 million ha and 14 billion m<sup>3</sup>, respectively, during 2014-17. Bangladesh would need additional 2.81 million ha land and 12 billion m<sup>3</sup> water to be cereal self-sufficient, increasing the country's national GHG emission footprint. Enteric fermentation, rice cultivation, manure, and fertilizers were found to be the major sources of GHG emissions. However, energy used in agriculture, mainly for mechanization and irrigation purposes, adds to GHG emissions, and there is potential to use renewable energy sources in an attempt to reduce the GHG emissions. An integrated management of water, energy, and carbon should be considered as one of the strategies to increase the cereal crop production and reduce GHG emissions from agriculture in Bangladesh, and thus contributing to the developmental progress of the country.

Future studies to assess the carbon embedded in crop-wise production against different scenarios of land, water, energy consumption, and other inputs could provide detailed insights into the policy alternatives to reduce the resource use per unit crop production leading to sustainable agriculture. Also, the cascading impact of disasters (natural hazards, conflicts, and war) leading to disruptions in food supply chains (trade) [34, 35, 36] are likely to alter the distribution of virtual land, water, and carbon emission, which could be explored in future studies.

One of the limitations of the present study is the unavailability of data for recent years. The results with increased timespan of cereal trade matrix, food balance sheet, and energy consumption in agriculture until the current year are likely to improve the insights. The present study perspective is from Bangladesh's point of view. GHG emissions from agriculture (mainly production of cereal crops and their export) from the partner countries, which is likely to vary depending on adopted technologies, remain out of the scope of the present study. In addition to the land and water footprints, future studies should incorporate the GHG footprints depending on the data availability.

## ACKNOWLEDGEMENT

This research is supported by the UK Research and Innovation Global Challenges Research Fund (UKRI GCRF) Living Deltas Hub (NERC Grant NE/S008926/1, 2019-24).

## REFERENCES

- [1] Liu X., Klemeš J., Varbanov P., Čuček L. and Qian Y. 2017. Virtual carbon and water flows embodied in international trade: a review on consumption-based analysis. *Journal of Cleaner Production* 146: 20-28.
- [2] Rosa L., Chiarelli D., Tu C., Rulli M. and D'Odorico P., 2019. Global unsustainable virtual

- water flows in agricultural trade. *Environmental Research Letters* 14 (11):114001.
- [3] FAO, 2009. Water at a Glance. The relationship between water, agriculture, food security and poverty. Water Development and Management Unit, Food and Agriculture Organization (FAO) of the United Nations, Rome, Italy.
- [4] Rosa L., Rulli M. C., Davis K.F., Chiarelli D.D., Passera C. and D'Odorico P., 2018. Closing the yield gap while ensuring water sustainability. *Environmental Research Letters* 13(10): 104002.
- [5] Smil V., 2017. Energy and Civilization: A History, Cambridge, MA, USA; London, UK: The MIT Press.
- [6] Schneider U. and Smith P., 2009. Energy intensities and greenhouse gas emission mitigation in global agriculture. *Energy Efficiency* 2 (2): 195-206.
- [7] [7] Ghorbani R., Mondani F., Amirmoradi S., Feizi H., Khorramdel S., Teimouri M., Sanjani S., Anvarkhah S. and Aghel H., 2011. A case study of energy use and economical analysis of irrigated and dryland wheat production systems. *Applied Energy* 88 (1): 283-8.
- [8] Pelletier N., Audsley E., Brodt S., Garnett T., Henriksson P., Kendall A., Kramer K., Murphy D., Nemecek T. and Troell M., 2011. Energy intensity of agriculture and food systems. *Annual review of environment and resources*, 36: 223-246.
- [9] Arizpe N., Giampietro M. and Ramos-Martin J., 2011. Food security and fossil energy dependence: an international comparison of the use of fossil energy in agriculture. *Critical Reviews in Plant Sciences*, 30(1-2): 45-63.
- [10] Harchaoui S. and Chatzimpiros P., 2019. Energy, Nitrogen, and Farm Surplus Transitions in Agriculture from Historical Data Modeling. *Journal of Industrial Ecology*, 23 (2): 412-25.
- [11] UN, 2013. World Population Prospects: The 2012 Revision," United Nations Department of Economics and Social Affairs [Online] Retrieved August 1, 2020 from the World Wide Web: <https://www.un.org/en/development/desa/publications/world-population-prospects-the-2012-revision.html>.
- [12] FAO. 2020. FAOSTAT [Online] Retrieved July 25, 2020 from the World Wide Web: <http://www.fao.org/faostat/en/#data>.
- [13] IPCC, 2014. Climate Change 2014: Mitigation of Climate Change in Contribution of Working Group III to the Fifth Assessment Report of the Intergovernmental Panel on Climate Change, Edenhofer O., Pichs-Madruga R., Sokona Y., Farahani E., Kadner S., Seyboth K., Adler A., Baum I., Brunner S., Eickemeier P., Kriemann B., Schlömer S. J. S., von Stechow C., Zwickel T. and Minx J., Eds., Cambridge, United Kingdom and New York, NY, USA, Cambridge University Press, p. 1454.
- [14] EPA, 2020. Global Greenhouse Gas Emissions Data," Environmental Protection Agency [Online]. Retrieved August 5, 2020 from the World Wide Web: <https://www.epa.gov/ghgemissions/global-greenhouse-gas-emissions-data>.
- [15] Bennetzen E., Smith P. and Porter J., 2016. Greenhouse gas emissions from agriculture can fall despite increased food production. *Global Change Biology*, 22: 763-781.
- [16] Udmale P., Pal I., Szabo S., Pramanik M. and Large A., 2020. Global food security in the context of COVID-19: A scenario-based exploratory analysis. *Progress in Disaster Science* 7: 100120.
- [17] D'Odorico P., Carr J., Laio F., Ridolfi L. and Vandoni S., 2014. Feeding humanity through global food trade. *Earth's Future* 2 (9): 458-69.
- [18] Hillier J., Hawes C., Squire G., Hilton A., Wale S. and Smith P., 2009. The carbon footprints of food crop production. *International Journal of Agricultural Sustainability*, 7 (2): 107-118.
- [19] Zhang D., Shen J., Zhang F. and Zhang W., 2017. Carbon footprint of grain production in China. *Scientific Reports* 7(1):1-11.
- [20] Peters G. P., Davis S. and Andrew R., 2012. A synthesis of carbon in international trade. *Biogeosciences* 9: 3247–3276.
- [21] Pramanik M., Diwakar A., Dash P., Szabo S. and Pal I., 2020. Conservation planning of cash crops species (*Garcinia gummi-gutta*) under current and future climate in the Western Ghats, India. *Environment, Development and Sustainability*, <https://doi.org/10.1007/s10668-020-00819-6>.
- [22] FAO, 2016. The agriculture sectors in the intended nationally determined contributions: Analysis. FAO, Rome, Italy.
- [23] Mekonnen M. and Hoekstra A., 2010. The green, blue and grey water footprint of crops and derived crop products, Value of Water Research Report Series No. 47. UNESCO-IHE, Delft, the Netherlands.
- [24] Mekonnen M. M. and Hoekstra A. Y., 2011. The green, blue and grey water footprint of crops and derived crop products. *Hydrology and Earth System Sciences* 15: 1577-1600.
- [25] FAO, 2020. Technical Conversion Factors for Agricultural Commodities," 2020. [Online]. Retrieved July 26, 2020 from the World Wide Web: <http://www.fao.org/fileadmin/templates/ess/documents/methodology/tcf.pdf>.
- [26] Mottaleb K., Krupnik T., Keil A. and Erenstein O., 2019. Understanding clients, providers and the institutional dimensions of irrigation services in developing countries: A study of water markets in Bangladesh. *Agricultural Water Management*, 222: 242-253.
- [27] [27] Kritee K., Nair D., Zavala-Araiza D., Proville J., Rudek J., Adhya T., Loecke T., Esteves T., Balireddygar S., Dava O. and Ram K., 2018.



- High nitrous oxide fluxes from rice indicate the need to manage water for both long-and short-term climate impacts. *Proceedings of the National Academy of Sciences* 115 (39): 9720-9725.
- [28] Zou X., Li K., Cremades R., Gao Q., Wan Y. and Qin X., 2015. Greenhouse gas emissions from agricultural irrigation in China. *Mitigation and Adaptation Strategies for Global Change* 20 (2): 295-315.
- [29] MoEF, 2018. Bangladesh Climate Change Strategy and Action Plan 2008. Ministry of Environment and Forests (MoEF), Government of the People's Republic of Bangladesh, Dhaka, Bangladesh.
- [30] Wang Z., Gu D., Beebout S., Zhang H., Liu L., Yang J. and Zhang J., 2018. Effect of irrigation regime on grain yield, water productivity, and methane emissions in dry direct-seeded rice grown in raised beds with wheat straw incorporation. *The Crop Journal*, 6 (5): 495-508.
- [31] MoEFCC, 2018. Roadmap and Action Plan for Implementing Bangladesh NDC: Transport, Power and Industry Sectors. Ministry of Environment, Forest and Climate Change (MoEFCC), Dhaka, Bangladesh.
- [32] Ali M., Hoque M. and Kim P. J., 2013. Mitigating global warming potentials of methane and nitrous oxide gases from rice paddies under different irrigation regimes. *Ambio* 42 (3): 357-68.
- [33] Bangladesh Planning Commission, 2018. Bangladesh Delta Plan (BDP) 2100. Government of the People's Republic of Bangladesh, Dhaka, Bangladesh.
- [34] Pal I. and Bhatia S., 2018. Disaster risk governance and city resilience in Asia-Pacific region. *Science and Technology in Disaster Risk Reduction in Asia Potentials and Challenges*. 137-159. Academic Press.
- [35] Mohanty A., Hussain, M., Mishra, M., Kattel D.B., and Pal I., 2019. Exploring community resilience and early warning solution for flash floods, debris flow and landslides in conflict prone villages of Badakhshan, Afghanistan. *International Journal of Disaster Risk Reduction* 33: 5-15.
- [36] Lwin K. K., Pal I., Shrestha S. and Warnitchai, P., 2020. Assessing social resilience of flood-vulnerable communities in Ayeyarwady Delta, Myanmar. *International Journal of Disaster Risk Reduction* 51: 101745.



[www.ericjournal.ait.ac.th](http://www.ericjournal.ait.ac.th)

## Factors Affecting Small-Scale Fishers Adaptation toward the Impacts of Climate Change: Reflections from South Eastern Bangladeshi Fishers

Edris Alam<sup>\*,#,1</sup>, Al-Ekram Elahee Hridoy<sup>#,^</sup>, and Mohammad Naim<sup>+</sup>

**Abstract** – The main objective of this research is to understand fishers' perceptions of climate change and to identify factors that influence their expectations concerning adapting to change. Two coastal communities at Salimpur on the Sitakunda coast and Sarikait in Sandwip Island were selected as a case study to analyse fishers' perceptions of climate change in southeastern Bangladesh. This research involved a questionnaire survey to interview 135 male fishers in two areas, who are professional fishers. Exploratory factor analysis and a binary logistic regression were adopted for empirical analysis. From the fishers surveyed, 84% opined that they might adapt and continue the fishing profession in response to climate change. The results suggested that fishers, although they have experienced formal and institutional barriers to adaptation in response to climate change and pursued alternative livelihoods as adaptation strategies, may continue to a fishing profession in the future. On the contrary, the fishers who have generated a high fishing income and experienced extreme climate events may not continue to a fishing profession. Fishers also cited climatic factors along with non-climatic factors (fishing ban, no return on investment, low supply of caught fish) as the reasons hindering their adaptation strategies in response to climate change.

**Keywords** – adaptation, Bangladesh, climate change, fisheries management, fishers' perception.

### 1. INTRODUCTION

The global climate is changing, and the effects are impacting both the ecosystem and human well-being [1], [2]. In the last century, the global average temperature has increased by 0.74°C, as reported in the Fourth Assessment Report. The Fifth Assessment (AR5) report of the Intergovernmental Panel on Climate Change (IPCC) revealed that between 1880 and 2020, the globally averaged combined land, and the ocean surface temperature was 0.85°C. Also, AR5 noted that global ocean warming is the greatest near the surface. Over the period 1971–2010, ocean warming has increased by 0.11°C per decade [3]. The IPCC also stated that their simulation produced an average temperature rise by 1.8–4°C depending on various emission scenarios [4]. The AR5 reported that since about 1950, changes had been observed in extreme weather and climate events (warm temperature extremes, heavy precipitation and extremely high sea levels). The IPCC also reported in 2018 that anthropogenic global warming had reached about 1°C above global average temperatures between 1850–1900 and if it continues to rise by a current rate of 0.2°C per

decade global warming is likely to reach 1.5°C between 2030 and 2052 [5]. This rate of warming indicates that climate change is inevitable and impacts on the future development of humans and the environment may be substantial, particularly in respect to the world's marine ecosystem functions [6]–[8]. Increased water temperature impacts aquatic organisms and the declining fish catch potential worldwide [9], [10].

Moreover, changes in fish distribution and abundance are likely to affect the fishing profession, fishery-based livelihoods, and associated industries [11]. In Bangladesh, the mean annual temperature, between 1958 and 2007, has increased by 0.10°C [12]. The global mean surface temperature increased by 0.12°C per decade [3]. Rahman, *et al.* [13] investigated temperature scenarios for Bangladesh for 2050 and indicated that the monthly mean surface air temperature could increase between 0.5 and 2.1°C. Simulation models suggest that climate change will lead to changes in primary productivity, shifting in distribution, and changes in the potential catch of marine resources, leading to global impacts on the fishing industry [14].

The fisheries sector in Bangladesh contributed 3.57 percent of the National Gross Domestic Product (GDP) in the fiscal year of 2018, and in 2017–2018 it accounted for one-fourth of agricultural GDP. In 2018, the contribution to GDP by agriculture and industry was 13.07% and 28.54%, respectively. Over 11 percent of the total population of Bangladesh is wholly or partially involved in this sector for their livelihoods [15]. In terms of food and nutrition supply, the population of Bangladesh receive 60 percent of animal protein from this sector. Furthermore, small-scale coastal fisheries support the livelihoods of half a million fishers and the members of their households [15]. Such fishers capture 82 percent of Bangladesh's overall marine catch [15].

\* Faculty of Resilience, Rabdan Academy, Abu Dhabi, UAE.

# Department of Geography and Environmental Studies, University of Chittagong, Chittagong-4331, Bangladesh.

^ Disaster and Development Organization (DADO), Bangladesh.

+ Department of Electrical and Computer Engineering, North South University, Dhaka – 1229, Bangladesh.

<sup>1</sup>Corresponding author;  
Tel: +971 25999111.  
E-mail: [eam@ra.ac.ae](mailto:eam@ra.ac.ae)

Despite this, the fisheries sector of Bangladesh is susceptible to climate change and global variability [16]. Various climatic variables, including tropical cyclones and temperature, salinity, sea-level rise, water temperature, precipitation, and drought, have adversely affected the sustainability of coastal fishing, thus affecting the livelihood and well-being of fishing communities [17], [18]. Climate change is expected to have a significant impact on fishery-based livelihoods [19]. Coastal communities in Bangladesh are consistently adopting instinctive survival strategies to live under changing climatic conditions [20]-[22].

Climate change and its related impacts are said to have significantly impacted coastal means of life, ecosystems, human settlement, and water resources. In the Bay of Bengal, Bangladesh's coastline and offshore islands such as Sandwip, Kutubdia, and Hatiya are subjected to frequent tropical cyclones. The increase in the height of storm surges caused by intense tropical cyclones could be magnified by low lying land on the coast of Bangladesh along with the rise in sea level in the northern Bay of Bengal [23], [24]. Haque [25] states that in Bangladesh, coastal regions are frequently affected by tidal flooding, floods, and storm surges. Biswas, *et al.* [26] reported that about 21 percent of the south and southeast coastal areas of Bangladesh were affected by high to very high storm and tidal surge. Chowdhury, *et al.* [27] reported that increasing temperature and pH variation due to climate change might affect the marine fish species and affect the distribution pattern of some fish species. The small-scale fishing communities of Bangladesh are less educated and live along the coast of the Bay of Bengal. Thus, the economic hardship of these fishers is likely to be impacted by climate change. Studies, [27], [28] which mentioned the effects of climate change on the marine fishery resources (hilsa and shrimp) and the distribution pattern of marine fish species in Bangladesh coastal areas, also state that increased temperature might cause some fish species to migrate to a higher latitude or towards the sea.

Marine fisheries account for 16.28 percent of National fish production [29]. Shamsuzzaman, *et al.* [30] suggest that marine fisheries' contributions to the total fish production in Bangladesh has declined from twenty-one percent to sixteen percent (21.30% to 16.18%) throughout 2000 to 2015. Other findings reinstated this when Barange, *et al.* [31] showed that the fish production in the marine waters of Bangladesh is likely to decrease to less than ten percent due to the impacts of climate change.

According to the IPCC, adaptation is "the process of adjustment to the actual or expected climate and its effects." In human systems, adaptation seeks to moderate or avoid harm or exploit beneficial opportunities. Natural environments and natural interventions may also facilitate adjustment to climate change and its effects [3]. However, there is a lack of grounded research in this area, namely, to identify local-

level symptoms of climate change, its impacts, community-level adaptation and resilience [20]. Islam, *et al.* [11] analysed the vulnerability of fishery-based livelihoods to the impacts of climate variability and change in two coastal fishing communities in Bangladesh. Adaptation can be positive or negative, and the inability to recognise climate change can lead to maladaptation. Thus, awareness of climate change is needed to prevent maladaptation within the Bangladeshi fishing industry.

Vulnerabilities are those factors that compromise the capacity of a community to prepare and respond to natural hazards. Islam, *et al.* [11] identified that livelihood vulnerability includes exposure to floods and cyclones, sensitivity, and lack of adaptive capacity in terms of physical, natural, and financial capital, as well as diverse livelihood strategies that vary depending on location and context. Islam, *et al.* [32] also identified the restrictions of and barriers to climate change adaptation among the Bangladeshi fishing communities. The limits include physical characteristics of the climate and the sea, such as the frequency and duration of tropical cyclones, and hidden sandbars, which obstruct the safe return of the fishers to communities on the coast [32]. The barriers to climate change adaptation include technologically inferior boats, weak radio signals, low incomes, credit inaccessibility, unfavourable credit schemes, inaccurate weather forecasts, underestimation of cyclone occurrence, coercion of fishers by boat owners and captains, lack of education, skill and livelihood alternatives, lack of enforcement of fishing regulations and maritime laws, and the lack of access to fish markets.

Hasan and Nursey-Bray [33] studied fishers' perceptions in response to climate change, where the authors mentioned a few important determinants (geographic characteristics and disaster experiences) that shape the fishers' views about climate change. Jahan, *et al.* [34] investigated fishers' perceptions on the effect of climate change and anthropogenic impact on Hilsa fishery at lower Meghna river, where the authors reported that the stock of Hilsa is declining due to several adverse climatic conditions. Billah, *et al.* [35] studied fishers' perception of climate change on saltmarsh and seagrass ecosystems in the southeastern coast of Bangladesh, where the authors reported that fishers are helpless to face the effects of climate change due to their poverty especially less income source and food deficiency. Chen [36] identified factors that influence Taiwanese fishers' perception in response to climate change and developed an empirical model to predict the influences on fishers' willingness to adapt their fishing behaviours under climate change. However, studies related to identifying critical factors, in particular socio-economic factors and climate change perceptions, that influence fishers' eagerness to adapt to fishing activities under climate change is limited in Bangladesh.

Therefore, this research aimed to improve understanding of local-level climate change perceptions,

adaptation constraints, and community-led adaptation strategies of the fishing communities in south-eastern Bangladesh. Subsequently, it determines the essential factors that influence the fishing behaviour of south-eastern Bangladeshi fishers in response to climate change. The findings intend to help government agencies, decision-makers, and fishery managers develop coherent and comprehensive strategies for enhancing fishing communities' resilience to climate change on the Bangladesh coast.

## 2. METHODS

### 2.1 Study Area

Sandwip Island and Sitakunda are located on the southeast Bangladesh coast (Figure 1). For this study, both offshore and mainland coastal households have been selected that carry out fishing activities in the Bay of Bengal. Also, the fishers' communities from the villages of Sarikait in Sandwip Island and Salimpur in Sitakunda mainland coast were consulted. These fishing communities are located on the shores of the Bay of Bengal, which makes these areas highly vulnerable to floods, cyclones, erosion, and storm surges. The monthly mean sea surface temperature (SST) was between 23.4°C (January) and 29.2°C (May) in the coastal waters of Sandwip and Sitakunda mainland coast area with the average SST throughout the year of 28°C. The total population of Sarikait is 24, 543, of which 900 people are coastal fishers, according to the last census conducted in 2011. Salimpur, located in the coastal belt of Sitakunda, has a total population of 54,797, of which 734 people are coastal/offshore fishers. In our study areas, two categories of marine fisheries were found.

The first is industrial fishers, who go for deep-sea fishing involving high-level technology to participate in large scale fishing. The second is artisanal fishers, who go out approximately eight kilometres from the coast to participate in small-scale fishing.

### 2.2 Survey Methods

In terms of climate change, the fishers' perceptions of the impacts emanated from extreme weather events are important for fisheries-related decision making. This study aims to identify local fishing communities' perceptions of climate change and identify the significant factors which affect fishers' response to climate change. Only a few studies, to the best of our knowledge, have discussed the determinants on the practices of fishers regarding climate change; thus, there is still insufficient literature to identify these important factors. Hasan and Nursey-Bray [33] mentioned a few important determinants (geographic characteristics, disaster experiences, socio-economic status, and worldviews) that shape fishers' perceptions about climate change. Fishers' characteristics, socio-economic status, and experiences are critical factors in influencing fishers' perceptions and adaptation measures regarding climate change [37]. Before conducting the field survey, a list of fishers' households from the selected study areas was gathered from both the Salimpur and Sarikait union councils. The study was conducted on fishers who fish as a primary source of income and have continued this profession for generations. From the selected household list, the formal survey was conducted between August 2019 and September 2019 and 135 fishers were interviewed face-to-face using a structured questionnaire survey which consists of 23 questions.

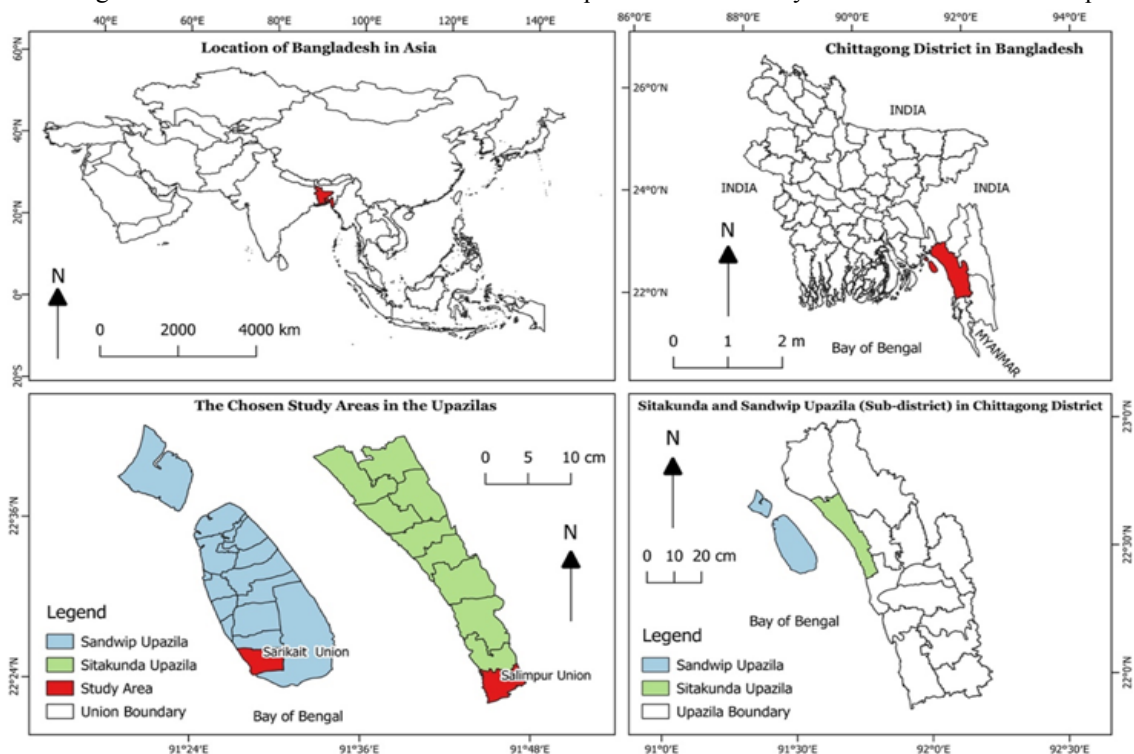

Fig. 1. Location of selected study areas.



A simple random sampling technique was applied to select the participants. Of these 135 participants, 68 were from Sitakunda and 67 from Sandwip. The total fishers of these selected areas were 1634 (900 + 734), 135 responses can reach a sampling error level of 0.08. For further analysis in this study, a total of 135 samples are, therefore, admissible. A 5 Likert scale can perform a good measurement statistically [38]. In this research, the questions were set using a 5-point Likert scale, which ranged from 1 to 5 (strongly disagree, disagree, neutral, agree, and strongly agree).

### 2.3 Analysis

To find noticeable patterns among many variables or items, researchers often use the factor analysis method [36]. Factor analysis can be used to reduce many variables into a smaller and more manageable number of factors [52], [53]. Exploratory factor analysis reveals patterns among the inter-relationships of the items or variables [54].

#### 2.3.1 Factor analysis

Factor analysis is used to determine the underlying factors or latent variables among questionnaires' items or observed variables. In exploratory factor analysis, the associations between latent and observed variables are called factor loadings. Exploratory factor analysis with the principal components method and varimax rotation has been used to minimise the many variables and examine the underlying dimensions of risk perceptions, adaptation constraints, and adaptation strategies. The principal component method can be used to solve high-dimensional multicollinearity issues of questionnaire data for estimating logistic models [39]. Before performing factor analysis, the Kaiser-Meyer-Olkin Measure of sampling adequacy (KMO) and Bartlett's Test of Sphericity were employed to check whether the variables are suitable to run factor analysis. KMO tests the proportion of variance in the data and how data is suited for factor analysis; the value range between 0 and 1 with test results greater than 0.6 are acceptable for factor analysis. Bartlett's Test of Sphericity is another evaluation of the factorability in data. Bartlett's test checks whether observed variables inter-correlate to the identity matrix. If the test is statistically significant, factor analysis is admissible. Also, factors with an eigenvalue greater than one are acknowledged for extracted factors.

The extracted items with factor loadings less than 0.5 should not be considered for factor analysis [40]. Thus, items of those factors with factor loading values less than 0.5 were dismissed.

#### 2.3.2 Test of Internal Reliability

Internal reliability is a measure that checks whether different items on the same test produce a similar score based on the correlations between given items. Cronbach's alpha measure to test internal reliability was employed in this present study. The Cronbach's alpha

( $\alpha$ ) ranges between 0 and 1. High values are desirable but very high reliabilities (0.95 or higher) are not; since it indicates that items may be redundant [41]. An alpha score higher than 0.7 is acceptable [42].

#### 2.3.3 Model

OLS (Ordinary Least Square) with dichotomous dependent variables leads to statistical problems (homoskedasticity or heteroskedasticity). Heteroskedasticity often leads to erroneous conclusions in hypothesis testing; thus, this study used binary logistic regression, as empirical modelling estimates the relationship between independent variables to a dichotomous variable. In addition, Maximum Likelihood Estimation (MLE) estimates the parameters of a logistic regression; thus, avoiding such statistical problems. A binary logistic regression with the MLE approach is considered for this study. This study aims at identifying the influencing factors in the fishers' decisions to adapt their fishing activities in response to climate change.

The eagerness of fishers to adapt their fishing activities is the dependent variable (Y), as follows:

$$Y = 1, 0 \quad (1)$$

where 1(yes) indicates that in response to climate change, a respondent may adapt fishing activities and 0 (no) indicates that the respondent may not adapt fishing activities in response to climate change. In the empirical model,  $p$  is the expected value of Y,

$$p = P(y = 1 | x_1, x_2, \dots, x_p) \quad (2)$$

where  $P(y = 1 | x_1, x_2, \dots, x_p)$  is the probability of changing fishing activities when the given independent variables are  $(X_1 = x_1, X_2 = x_2, X_K = x_K)$ . Thus, the significant independent variables  $(X_1, X_2, \dots, X_K)$  that influence  $p$  were found; the nonlinear logistic model used is represented by Equation 3:

$$p = \frac{e^{\beta_0 + \beta_1 x_1 + \beta_2 x_2 + \dots + \beta_p x_p}}{1 + e^{\beta_0 + \beta_1 x_1 + \beta_2 x_2 + \dots + \beta_p x_p}} \quad (3)$$

where  $\beta$  is the parameter to be estimated. According to the estimation procedure, the logistic model can be transformed into Equation 4:

$$\ln \frac{p}{1-p} = \beta_0 + \sum_{i=1}^k \beta_i x_i \quad (4)$$

where  $\ln \frac{p}{1-p}$  is log odds,  $p$  is the probability that Y for cases equals 1,  $1 - p$  is the probability that Y for cases equals 0,  $\beta_0$  is intercept term,  $\beta_i$  are the coefficients associated with each explanatory variables  $x_i$ . The coefficients in the logistic regression were estimated using the maximum likelihood estimation method.

### 3. RESULTS

#### 3.1 Profile of Respondents

The demographic characteristics of the respondents are shown in Table 1. From the total sample of the respondents, all of them are male; 50.4% lived in Salimpur, 49.6% lived in Sarikatpur. Most respondents had less than five years of education (53.3%), with 43%

having primary education and 3.7% had completed secondary education. Of the total respondents, most were under 50 years of age (40.0%); 14.8% were between the ages of 51–55. Additionally, about 42.22% had 30-40 years of fishing experience. Furthermore, 28.9% of respondents reported that their monthly income from fishing occupation is between BDT 15000 to 20000.

**Table 1. Summary statistics of the respondents.**

Total					
Age		Experience		Income	
Age group	Frequency (%)	Fishing experience (years)	Frequency (%)	Income (BDT)	Frequency (%)
≤50	54 (40)	10-20	7 (5.19)	5001-10000	4 (3)
51-55	20 (14.8)	21-30	27 (20.0)	10001-15000	26 (19.3)
56-60	18 (13.3)	31-40	57 (42.22)	15001-20000	39 (28.9)
61-65	16 (11.9)	41-50	28 (20.74)	20001-25000	32 (23.7)
66-70	19 (14.1)	51-60	13 (9.63)	25001-30000	24 (17.8)
>70	8 (5.9)	60+	3 (2.22)	>30000	10 (7.4)
Total	135 (N=100)				
Sitakunda					
Age		Experience		Income	
Age group	Frequency (%)	Fishing experience (years)	Frequency (%)	Income (BDT)	Frequency (%)
≤50	27 (39.70)	10-20	6 (8.82)	5001-10000	4 (5.88)
51-55	12 (17.65)	21-30	13 (19.11)	10001-15000	13 (19.11)
56-60	11	31-40	28 (41.17)	15001-20000	22 (32.35)
61-65	8	41-50	15 (22.05)	20001-25000	16 (23.52)
66-70	8	51-60	5 (7.35)	25001-30000	10 (14.70)
>70	2	60+	1(1.47)	>30000	3(4.41)
Total	68 (N=100)				
Sandwip					
Age		Experience		Income	
Age group	Frequency (%)	Fishing experience (years)	Frequency (%)	Income (BDT)	Frequency (%)
≤50	27 (40.29)	10-20	1 (1.49)	5001-10000	63 (94.03)
51-55	12 (17.91)	21-30	14 (20.89)	10001-15000	2 (2.98)
56-60	7 (10.44)	31-40	27(40.29)	15001-20000	-
61-65	8 (11.94)	41-50	13 (19.40)	20001-25000	-
66-70	7 (10.4)	51-60	8(11.94)	25001-30000	1 (1.49)
>70	6 (8.95)	60+	2(8.95)	>30000	1(1.49)
Total	67 (N=100)				

Note: Number in parenthesis indicates per cent distribution. BDT=Bangladeshi Taka (currency unit in Bangladesh).

#### 3.2 Factor Analysis Results

An exploratory factor analysis on the raw data was employed to explore the latent structure of the items and identify the factors that can influence fishers’ perception to adapt concerning climate change. Three exploratory factor analyses were employed on three dimensions as “dimension of risk perception”, “dimension of adaptation constraints”, and “dimension of adaptation strategies”.

The selected variables of each dimension were shown in Tables 3 to 5. Before performing exploratory factor analysis, the KMO test was employed to check

whether the variables are suitable to run factor analysis. The analysis results showed that all KMO assessments were admissible (0.877, 0.7133, and 0.704). Also, Bartlett’s Test of Sphericity is found significant for factor analysis. KMO test and Bartlett’s test results suggested these variables are eligible for further analysis. Furthermore, the Cronbach’s  $\alpha$  of these extracted factors were  $\alpha=0.826$ , 0.816, and 0.707, which are above the acceptable level 0.7. Additionally, all the item’s communality score was higher than the cut-off value 0.3 (Table 2).

In this study, factor loading values less than 0.5 were deleted as suggested by [40]. Factors with an eigenvalue greater than one have been considered.

In the dimension of risk perception, two factors evolved with the eigenvalues that were greater than one were extracted. The factors are as follows: (1) IPE (eigenvalue=7.446, proportion=43.494); (2) OI (eigenvalue=2.317, proportion= 43.494). In adaptation

constraints dimension, two factors were extracted. The factors are as follows: (1) NT (eigenvalue=7.446, proportion=43.494); (2) FI (eigenvalue=2.317, proportion= 43.494). Then, two factors were also considered in terms of the dimension of adaptation strategies; (1) AL (eigenvalue=3.352, proportion=35.48); (2) NO (eigenvalue=1.191, proportion=33.68).

**Table 2. Values of communality for all variables.**

Risk Perception		Adaptation constraints		Adaptation Strategies	
Variable	Communality	Variable	Communality	Variable	Communality
Increased high rainfall	0.805	Poor quality of boats increases the risk during inclement weather	0.551	Women forced to work outside	0.871
Increased height of storm surge	0.636	Inaccurate information about the weather	0.726	Engaged with alternative income sources	0.942
Increased intensity of wind speed of tropical cyclones	0.889	Increased frequency of tropical cyclones	0.532	Temporary displacement to elsewhere	0.512
Increased frequency of tropical cyclones	0.858	Unfavourable credit schemes sometimes put more pressure during extreme weather events	0.850	Involved in fish drying and processing instead of catching	0.767
Increased sea level	0.680	Lack of access to fish markets	0.602	Engaged in more farming activities compared to fishing	0.995
Decreased sea level	0.876	Lack of enforcement of fishing regulations and maritime laws	0.936	Women forced to work outside	0.871
Decreased cool days/nights	0.585	-	-	Engaged with alternative income sources	0.942
Decreased in total rainfall in the wet season	0.849	-	-	-	-
Number of annual rainy days decreased	0.898	-	-	-	-
More areas inundated by salinity	0.838	-	-	-	-
Decreased fish	0.815	-	-	-	-

Communality = The proportion of each variable's variance that can be explained by the *factors*.

### 3.3 Binary Logistic Model

Logistic regression is a regression model where the response variable is categorical. When there is a binary response variable, it is called a binary logistic regression model [55]. In this study, a binary logistic regression model was employed to determine the significant factors

that might influence the fishers' decision to adapt fishing activities in response to climate change.

#### 3.3.1 The Model and Variables

$$\ln \frac{p}{1-p} = \beta_0 + \sum \beta_i \times SE_i + \sum \beta_j \times PER_j \quad (5)$$

where SE is the socio-economic variable including (1) AGE: age of the respondents, (2) EXP: fishing experience (years), (3) EDU: education level of the respondents (years), and (4) monthly income of the respondents. Also, PER are the perception variables, and six variables were extracted via a factor analysis that includes: (1) IPE: extreme climate events and impacts on physical environment; (2) OI: observed impacts, (3) NT: natural and technological (4) FI: formal and institutional (5) AL: alternative livelihoods (6) NO: new opportunities. All variable descriptions are shown in Table 6.

### 3.3.2 Results of the Logistic Model

An empirical model was adopted to understand the factors that influence fishers' decisions to adapt their fishing activities in response to climate change. The empirical results are shown in Table 7. The goodness of fits of the models are Cox and Snell  $R^2$  is 0.177, and Nagelkere  $R^2$  is 0.301, the predicted probability is 84.4%, and the P-value of the Hosmer and Lemeshow test is 0.962 (where  $> 0.1$  is considered as acceptable); therefore, all indicators of the goodness of the fit of this model are well addressed.

**Table 3. Factor analysis of the risk perception dimension.**

Factor 1: Extreme climate events and impacts on the physical environment (IPE)				
Variable	Factor loading	Eigenvalue	Proportion	Cronbach's $\alpha$
Increased high rainfall	0.816			
Increased height of storm surge	0.794			
Increased intensity of wind speed of tropical cyclones	0.923			
Increased frequency of tropical cyclones	0.912	7.446	43.494	0.946
Increased sea level	0.647			
Decreased sea level	0.902			
No change in sea level	0.730			
Decreased fish	0.827			
Factor 2: Observed impacts (OI)				
Variable	Factor loading	Eigenvalue	Proportion	Cronbach's $\alpha$
Decreased cool days/nights	0.752			
Decreased in total rainfall in the wet season	0.902	2.317	28.185	-
Number of annual rainy days decreased	0.911			
More area being inundated by salinity	0.862			
Kaiser–Meyer–Olkin measure of sampling adequacy = 0.877				
Bartlett's test of sphericity (significant) = 0.000				

**Table 4. Factor analysis of the adaptation constraints dimension.**

Factor 1: Natural and technological (NT)				
Variable	Factor loading	Eigenvalue	Proportion	Cronbach's $\alpha$
Poor quality of boats increases the risk during inclement weather	0.740	3.288	41.344	0.816
Inaccurate information about the weather	0.816			
Increased frequency of tropical cyclones	0.613			
Unfavourable credit schemes sometimes put more pressure during extreme weather events	0.918			
Factor 2: Formal and institutional (FI)				
Variable	Factor loading	Eigenvalue	Proportion	Cronbach's $\alpha$
Lack of access to fish markets	0.766	2.317	28.185	-
Lack of enforcement of fishing regulations and maritime laws	0.952			
Kaiser–Meyer–Olkin measure of sampling adequacy = 0.713				
Bartlett's test of sphericity (significant) = 0.00				



**Table 5. Factor analysis of the adaptation strategies dimension.**

Factor 1: Alternative livelihoods (AL)				
Variable	Factor loading	Eigenvalue	Proportion	Cronbach's $\alpha$
Engaged with alternative income sources	0.816			
Temporary displacement to elsewhere	0.794	3.352	35.48	0.707
Involved in fish drying and processing instead of catching	0.923			
Factor 2: New Opportunities (NO)				
Variable	Factor loading	Eigenvalue	Proportion	Cronbach's $\alpha$
Women forced to work outside	0.752			
Engaged in more farming activities compare to fishing	0.902	1.191	33.68	

Kaiser–Meyer–Olkin measure of sampling adequacy = 0.707  
Bartlett's test of sphericity (significant) = 0.000

**Table 6. Explanatory variables in the binary logistic regression model.**

Dependent variable				
Variable	Description	Type	Mean	SD
Y	Will you adapt to fishing activities in response to climate change	Dummy variable 1 = Yes 0 = No	0.83	0.37
Independent variable				
Variable	Description	Type	Mean	SD
Personal variable (PV)				
AGE	Age of the respondent	Numeric variable	56.77	7.33
EDU	Education level of the respondent (years)	Numeric variable	1.48	1.93
FE	Fishing experience (years)	Numeric variable	38.98	11.79
Income	Monthly income of the respondent	Numeric variable	20018.98	5988.86
Risk perception variable (RP)				
IPE	Extreme climate events and impacts on the physical environment	Numeric variable	-	-
OI	Observed impacts	Numeric variable	-	-
Adaptation constrains variable (AC)				
NT	Natural and technological	Numeric variable	-	-
FI	Formal and institutional	Numeric variable	-	-
Adaptation strategies variable (AS)				
AL	Alternative livelihoods	Numeric variable	-	-
NO	New opportunities	Numeric variable	-	-

The empirical results suggest that the estimated coefficient of the variables Income, IPE, FI, and AL are statistically significant. Moreover, the variables FI and AL are seen to positively affect fisher's eagerness to adapt their fishing activities to the threat of climate change. Thus, the respondents who faced formal and institutional barriers as their stated constraints to adaptation and pursued alternative livelihoods may adapt to fishing behaviours in response to climate change. Also, Income and IPE negatively affect fishers' decisions to adapt fishing activities under climate

change. Thus, respondents who generate a low fishing income are more likely to adapt to the fishing activities in response to climate change than those who generate a high income. Furthermore, respondents who experienced extreme weather events might not adapt to new fishing activities under climate change. Relating to empirical results, the following sections discuss various factors in the understanding of the importance of the personal backgrounds and perceptions of fishers regarding adaptation barriers and adaptation strategies associated with extreme climatic risks.

**Table 7. Results of the binary logistic regression model.**

Variable	Coefficient	SE
AGE	0.057	0.054
EDU	0.100	0.134
FE	-0.039	0.033
Income	-0.001 *	0.000
IPE	-1.703 ***	0.621
OI	0.055	0.296
NT	0.548	0.570
FI	3.825 **	1.511
AL	3.486 ***	1.258
NO	13.237	8681.311
Constant	-0.388	-
Predicted probability	84.4%	-
Cox and Snell $R^2$	0.177	-
Nagelkere $R^2$	0.301	-
Hosmer and Lemeshow test	$\chi^2 = 2.488$	-
	$P\text{-value} = 0.962$	-

\*Significance at the 10% level, \*\*significance at the 5% level, \*\*\*significance at the 1% level

#### 4. DISCUSSION

Understanding fishers' perception of climate change is vital to their adoption and success of adaptation and mitigation strategies to climate change. Some critical information about the fishers' risk perception of climate change is important for fisheries-related policy-making in Bangladesh. Such policy-making in terms of climate change is limited; therefore, this study attempted to identify such critical factors via factor analysis and empirical modelling that might help to make fisheries-related policy. Climate change risk management needs to be considered for marine fishers' adaptive capacity [43], [44]. Therefore, the results concerning the fisher's perception of risk and adaptation constraints of climate change can improve fisheries' management strategies in response to climate change. In the risk management process, risk identification and risk assessment are essential [36], [45], [46]. In this present study, findings suggest that under the risk perception dimension, perception of extreme climate events and impacts on the physical environment (increased high rainfall, increased height of storm surge, increased intensity of wind speed of tropical cyclones, increased frequency of tropical cyclones, increased sea level, decreased sea level, and no change in sea level) have the highest variability and the highest eigenvalue (7.446) and proportion (43.494); thus, the findings indicate that the risk of extreme climate events is more important than other risks in the fishers' view. Islam, *et al.* [32] mentioned the type of limits and barriers to the adaptation of fishing activities to climate change.

In terms of adaptation constraint dimension, the fishers identified natural and technological barriers (NT) as more critical elements than formal institutional barriers (FI). For example, NTs poor quality of boats increases the risk during inclement weather, inaccurate

weather information, increased frequency of tropical cyclones, and unfavourable credit schemes □ may put more pressure on fishers during extreme weather events. The effects of these constraints may have an indirect and direct impact on the income and economic activities of fishers.

Fishers' perception of adaptation strategies is also addressed in this study. Alternative livelihoods (eigenvalue=3.352 and proportion=35.48) and new opportunities (eigenvalue= 1.191 and proportion =33.68) are two major adaptation strategies undertaken by fishers. These two adaptation factors include the items of engagement with alternative income sources, temporary displacement to elsewhere and involvement in fish drying and processing instead of catching, women forced to work outside, and engaged in more farming activities compared to fishing. Thereby, these items are essential factors for fishers to be included in climate change risk management.

Furthermore, 84 percent of the respondents opined that they would continue their fishing activities; thus, they may adapt in response to climate change. The empirical model found factors affecting the eagerness of fishers to adapt their fishing activities to climate change and the identified factors that might be important to implement relevant fishery-management policies in Bangladesh. In the empirical models, fishers' demographic characteristics and perceptions are considered. In response to climate change, the empirical results suggest that a few variables significantly influence fishers' fishing activities. Two variables significantly and positively affect fishers' eagerness to adapt fishing action: formal and institutional (FI) and alternative livelihoods (AL). Therefore, the respondents who perceived FI and pursued AL might adapt their fishing activities in response to climate change. Fisher's

communities frequently undertake adaptation strategies to cope with climate event losses.

Alternatively, Income and IPE significantly and negatively affected fisher's decisions; thus, respondents who generate high fishing income and are experiencing extreme climate events might not adopt fishing activities in response to climate change. In summary, fishers who may adapt their fishing activities in response to climate change are likely to have some of the following characteristics: (1) they are facing barriers in terms of access to fish markets and the enforcement of fishing regulations and maritime laws during adverse climatic conditions and events, (2) they already have undertaken some adaptation strategies such as engaging with alternative income sources, temporary displacement to elsewhere or are involved in fish drying and processing instead of catching to survive in adverse climatic conditions, and (3) they are generating low fishing incomes. These findings coincided with the earlier studies in the area following the April 1991 tropical cyclone that demonstrated that the members of the fishing community changed their profession temporarily to cope with the devastation of the storm before returning to their previous work [47], [48].

In addition, fishers' income and experience of extreme climate events are the two most significant factors that influence the fishers' eagerness to adapt fishing activities in response to climate change. Income is a significant socio-economic factor in terms of adaptation as more income makes it possible to prepare against the impacts of climate change and to speed up the recovery process [49]. Salik, *et al.* [49] also mentioned that small-scale fishers, who had low, diversified and intervallic income, had lower climate change adaptation levels. Income deficiencies increase the vulnerability of livelihoods through coping and adaptive capacity reduction [11]. However, based on the empirical results of this study, fishers who generated a low fishing income are more likely to adapt in response to climate change than those with higher fishing incomes.

Moreover, empirical results also suggest that people who perceived extreme climate impacts might not pursue fishing as a profession. In addition, fishers with low fishing incomes might be able to adapt; since low-income increases the likelihood of fishers adapting to climate change as fishing is their primary activity, and they lack the skills to switch to other jobs. Low-income may be associated with unstable climate and a decrease of fish-catch. On the other hand, a higher fishing income might decrease the likelihood of fishers adapting in response to climate change. In other reports, higher fishing incomes led to a greater awareness of climate change [50], [51]; thus, it might encourage fishers to continue with the fishing profession in response to adverse climate change.

About 94 per cent of Sandwip fishers generate less than 10,000 taka monthly (Table 1) from fishing activities. Among these, 86 per cent of the respondents

want to continue their fishing profession in response to climate change. The main reason for continuing the fishing profession is to maintain the current earning by the inherited fishing professional. They also expressed that, due to lack of experience in any other profession, they are at risk of even forfeiting their current income. The fishers reported that they face climatic and non-climatic challenges that hinder income from fishing activities. Events such as the recent government ban to catch in the Bay of Bengal, lack of return on investments, and housing changes due to erosion-induced landlessness have all led to fishers not having enough money for fishing.

Furthermore, in the adaptation constraints dimension, 84 per cent of the fishers state they may continue in the fishing profession despite the perceived formal and institutional barriers such as lack of enforcement of fishing regulations and maritime laws and less access to the fish market during climate change. Thus, the findings indicated that fishing is the primary occupation of respondents; however, they also pursue alternative livelihoods for increasing income, this may serve as adaptation strategy to climate change. The 49 per cent of respondents reported that they face barriers such as lack of access to the fish markets, while 62% opined that fishing ban regulations are inadequate as the implementation does not consider fishing communities welfare. Despite experiencing and recognising such barriers, the overwhelming majority opined they will continue to fishing activities. The fishers identified managing an alternative income source, temporary displacement to elsewhere, fish drying, and processing other adaptation strategies.

Overall, based on the empirical findings of this study, the following recommendations for policy implications are offered:

#### *a. Incentive programs for younger fishers*

From the empirical results, fishers with a higher fishing income might not adapt their fishing behaviours in response to climate change. In this study, most of the respondents were older and lacked other skills; thus, younger fishers with better incentives might adapt their fishing behaviours to climate change. The Government of Bangladesh (GoB) should attract younger fishers to the coastal fisheries sector with better incentive programs.

#### *b. Accurate weather information and warning dissemination*

Based on the findings of the empirical results, fishers who experienced extreme climate events might not adapt their fishing activities in response to climate change. Based on the factor analysis, natural and technological barriers to adaptation are important perceived factors for fishers. However, this is not a factor that influences the decisions of fishers to change fishing behaviours in response to climate change. When this factor is coupled with inaccurate weather information and poor-quality

boats, the vulnerability and risk to climate change and inclement weather increases.

Extreme weather events such as storm surges and cyclones are common in coastal areas of Bangladesh; thus, government agencies should try to increase awareness related to current conditions and disseminate timely warning signals to all fishing communities.

*c. Remove formal and institutional barriers:*

Despite facing formal and institutional barriers to adaptation, fishers still want to adapt their fishing activities in response to climate change. This implies that fishing is the primary activity of the respondents. Thus, removing formal and institutional barriers such as making markets more accessible for fishers and making fishing regulation favourable to fishers may help continue fishing activities in response to climate change.

*d. Diversifying income sources*

The adaptation strategies such as alternative income sources, temporary displacement to elsewhere, fish drying, and fish preservation techniques during the extreme weather events are significantly and positively affecting fishers' ability to continue fishing activities in response to climate change. Small-scale fishers are undertaking such strategies to reduce their vulnerability to climate change impacts. Thus, several government programs and non-governmental organisations (NGOs) may introduce new opportunities such as vocational and entrepreneurial-related jobs that will help fishers cope with the impacts of climate change.

## 5. CONCLUSION

This study contributes to the understanding of the factors that affect fishers' decisions to adapt to climate change. The results indicated, of the fishers surveyed, 84 percent opined that they might adapt and continue the fishing profession in response to climate change. This result indicated that fishers have the perception of climate change impacts and adaptation constraints in response to climate change. The empirical results also indicated that higher fishing incomes and perception of climate change impacts negatively affect their adaptation decisions. While on the other hand, the perception of adaptation constraints such as lack of access to fish markets, lack of enforcement of fishing regulations, and maritime laws significantly and positively affected their adapting decisions. The findings of this study may provide some insights to develop coherent and comprehensive strategies for improving the fishing community's resilience to climate change on the Bangladesh coasts.

Information about fishers' perceptions of climate change in other coastal regions of Bangladesh should be collated in the future for comprehensive and long-term community-led climate change adaptation research. The additional research could help policy-makers understand factors that influence fishers' adaptation decisions under climate change in a greater context and develop and

integrate adaptation policies according to the community's needs.

## ACKNOWLEDGEMENT

The funding for this work, granted by the Research and Publication Office of the University Chittagong to Edris Alam, is gratefully acknowledged. Thanks to the research assistants from the Disaster and Development Organisation (DADO) for data collection in southeast Bangladesh. The contents of the research have been much improved by considering positive feedback from Monica Farrow, Samuel Agele and Tasnia Noshin, who improved expression and conducted a language check.

## REFERENCES

- [1] Adger W.N., 2010. Climate change, human well-being and insecurity. *New Political Economy* 15(2): 275-292.
- [2] Pecl, G.T., Araújo, M. B., Bell, J. D., Blanchard, J., Bonebrake, T. C., Chen, I. C., and Williams, S. E., 2017. Biodiversity redistribution under climate change: Impacts on ecosystems and human well-being. *Science* 355(6332).
- [3] Intergovernmental Panel on Climate Change (IPCC), 2014. *Climate change 2014: impacts, adaptation, and vulnerability. Final draft IPCC WGII AR5 Technical Summary.*
- [4] Intergovernmental Panel on Climate Change (IPCC), 2007. *Climate Change 2007: impact, adaptation and vulnerability. Contribution of Working Group II to the fourth assessment report of the IPCC.* Cambridge University Press, Cambridge, 976 pp.
- [5] Intergovernmental Panel on Climate Change (IPCC), 2018. *Global Warming of 1.5 C An IPCC Special Report on the Impacts of Global Warming of 1.5 °C Above Pre-Industrial Levels and Related Global Greenhouse Gas Emission Pathways, in the Context of Strengthening the Global Response to the Threat of Climate Change. Sustainable Development, and Efforts to Eradicate Poverty.*
- [6] Cramer W., Bondeau A., Woodward F I., Prentice, I.C., Betts, R.A., Brovkin, V., and Young-Molling, C., 2001. Global response of terrestrial ecosystem structure and function to CO<sub>2</sub> and climate change: results from six dynamic global vegetation models. *Global Change Biology* 7(4): 357-373.
- [7] Hoegh-Guldberg O. and J.F. Bruno. 2010. The impact of climate change on the world's marine ecosystems. *Science* 328(5985): 1523-1528.
- [8] Walther G.R., Post E., Convey P., Menzel A., Parmesan C., Beebee T.J., and Bairlein F., 2002. Ecological responses to recent climate change. *Nature* 416(6879): 389.
- [9] Behrenfeld M.J., O'Malley R.T., Siegel D.A., McClain C.R., Sarmiento J.L., Feldman G.C., and



- Boss E.S., 2006. Climate-driven trends in contemporary ocean productivity. *Nature* 444(7120): 752-755.
- [10] Cheung W.W., Lam V.W., Sarmiento J.L., Kearney K., Watson R., and Pauly D., 2009. Projecting global marine biodiversity impacts under climate change scenarios. *Fish and Fisheries* 10(3): 235-251.
- [11] Islam M.M., Sallu S., Hubacek K., and Paavola J., 2014. Vulnerability of fishery-based livelihoods to the impacts of climate variability and change: insights from coastal Bangladesh. *Regional Environmental Change* 14(1): 281-294.
- [12] Shahid S., 2010. Recent trends in the climate of Bangladesh. *Climate Research* 42(3): 185-193.
- [13] Rahman M.M., Islam M.N., Ahmed A.U., and Georgi F., 2012. Rainfall and temperature scenarios for Bangladesh for the middle of 21st century using RegCM. *Journal of Earth System Science* 121(2): 287-295.
- [14] Sumaila U.R., Cheung W.W., Lam V.W., Pauly D., and Herrick S., 2011. Climate change impacts on the biophysics and economics of world fisheries. *Nature Climate Change* 1(9): 449-456.
- [15] DoF, 2018. Yearbook of Fisheries Statistics of Bangladesh, 2017-18. Fisheries Resources Survey System (FRSS), Department of Fisheries. Bangladesh: Ministry of Fisheries, 2018. 35:129.
- [16] Allison E.H., Perry A.L., Badjeck M.C., Neil Adger W., Brown K., Conway D., and Dulvy N.K., 2009. Vulnerability of national economies to the impacts of climate change on fisheries. *Fish and Fisheries* 10(2): 173-196.
- [17] Ahmed N., Occhipinti-Ambrogi A., and Muir J.F., 2013. The impact of climate change on prawn postlarvae fishing in coastal Bangladesh: socioeconomic and ecological perspectives. *Marine Policy* 39: 224-233.
- [18] Alam E., 2017. Coping and adaptation: coastal communities with disasters. Dhaka, pp. 105: AHDP publishing house.
- [19] Ficke A.D., Myrick C.A., and Hansen L.J., 2007. Potential impacts of global climate change on freshwater fisheries. *Reviews in Fish Biology and Fisheries* 17(4): 581-613.
- [20] Alam E. and A.E. Collins. 2010. Cyclone disaster vulnerability and response experiences in coastal Bangladesh. *Disasters* 34(4): 931-954.
- [21] Pouliotte J., Smit B., and Westerhoff L., 2009. Adaptation and development: Livelihoods and climate change in Subarnabad, Bangladesh. *Climate and Development* 1(1): 31-46.
- [22] Rawlani A.K. and B.K. Sovacool. 2011. Building responsiveness to climate change through community based adaptation in Bangladesh. *Mitigation and Adaptation Strategies for Global Change* 16(8): 845-863.
- [23] Ali A.M.S., 2006. Rice to shrimp: Land use/land cover changes and soil degradation in Southwestern Bangladesh. *Land Use Policy* 23(4): 421-435.
- [24] Karim M.F. and N. Mimura. 2008. Impacts of climate change and sea-level rise on cyclonic storm surge floods in Bangladesh. *Global Environmental Change* 18(3): 490-500.
- [25] Haque S.A., 2006. Salinity problems and crop production in coastal regions of Bangladesh. *Pakistan Journal of Botany* 38(5): 1359-1365.
- [26] Biswas J.C., Maniruzzaman M., Haque M.M., Hossain M.B., Rahman M.M., Naher U.A., and KGF K.G.F., 2019. Extreme climate events and fish production in Bangladesh *Environ Nat Resour Res* 9: 1-8.
- [27] Chowdhury M., Sukhan Z., and Hannan M., 2010. Climate change and its impact on fisheries resource in Bangladesh. In *Proceeding of International Conference on Environmental Aspects of Bangladesh (ICEAB10)*, Japan.
- [28] Hussain M. and M.E. Hoq, 2010. Impacts of climate change on coastal and marine fisheries resources in Bangladesh. *Sustainable Management of Fisheries Resources of the Bay of Bengal* 53: 53-73.
- [29] FRSS, 2016. Fisheries Statistical Report of Bangladesh, Vol. 32. Fast Response Survey System (FRSS), Department of Fisheries, Bangladesh, pp. 1-57.
- [30] Shamsuzzaman M.M., Islam M.M., Tania N.J., Al-Mamun M.A., Barman P.P., and Xu X., 2017. Fisheries resources of Bangladesh: Present status and future direction. *Aquaculture and Fisheries* 2(4): 145-156.
- [31] Barange M., Fernandes J.A., Kay S., Hossain M.A., Ahmed M., and Lauria V., 2018. Marine ecosystems and fisheries: trends and prospects. *Ecosystem Services for Well-Being in Deltas*. Palgrave Macmillan, Cham: 469-488.
- [32] Islam M.M., Sallu S., Hubacek K., and Paavola J., 2014. Limits and barriers to adaptation to climate variability and change in Bangladeshi coastal fishing communities. *Marine Policy* 43: 208-216.
- [33] Hasan Z. and M. Nursey-Bray, 2018. Artisan fishers' perception of climate change and disasters in coastal Bangladesh. *Journal of Environmental Planning and Management* 61(7): 1204-1223.
- [34] Jahan I., Ahsan D., and Farque M.H., 2017. Fishers' local knowledge on impact of climate change and anthropogenic interferences on Hilsa fishery in South Asia: evidence from Bangladesh. *Environment, Development and Sustainability* 19(2): 461-478.
- [35] Billah M.M., Zamal H., Mustafa Kamal A.H., Hoque A.R., Rahman M.M., Hoque M.M., and Hoque M.N., 2016. Saltmarsh and seagrass beds on the south-eastern coast of Bangladesh: vegetation characteristics and adjacent fisheries diversity. *Zoology and Ecology* 26(4): 313-322.

- [36] Chen J.-L., 2020. Fishers' perceptions and adaptation on climate change in northeastern Taiwan. *Environment, Development and Sustainability*: 1-24.
- [37] Zhang J., Fleming J., and Goericke R., 2012. Fishermen's perspectives on climate variability. *Marine Policy* 36(2): 466-472.
- [38] Dawes J., 2008. Do data characteristics change according to the number of scale points used? An experiment using 5-point, 7-point and 10-point scales. *International Journal of Market Research* 50(1): 61-104.
- [39] Aguilera A.M., Escabias M., and Valderrama M.J., 2006. Using principal components for estimating logistic regression with high-dimensional multicollinear data. *Computational Statistics & Data Analysis* 50(8): 1905-1924.
- [40] Lederer A.L. and V. Sethi. 1991. Critical dimensions of strategic information systems planning. *Decision Sciences* 22(1): 104-119.
- [41] Streiner D.L., 2003. Starting at the beginning: an introduction to coefficient alpha and internal consistency. *Journal of Personality Assessment* 80(1): 99-103.
- [42] George D., 2003. SPSS for Windows step by step: A simple guide and reference. *11.0 update (4th ed.)*. Boston, MA: Allyn & Bacon.
- [43] Hilborn R. and R. M. Peterman. 1996. The development of scientific advice with incomplete information in the context of the precautionary approach. *FAO Fisheries Technical Paper*: 77-102.
- [44] Shaffril H.A.M., Samah A.A., and D'Silva J.L., 2017. Climate change: Social adaptation strategies for fishermen. *Marine Policy* 81: 256-261.
- [45] Grafton R.Q., 2010. Adaptation to climate change in marine capture fisheries. *Marine Policy* 34(3): 606-615.
- [46] Sethi S.A., 2010. Risk management for fisheries. *Fish and Fisheries* 11(4): 341-365.
- [47] Alam E., 2002. Post cyclone adjustment process: the case of Sandwip, Bangladesh. *Unpublished MSc Thesis, Department of Geography and Environment, University of Dhaka, Bangladesh.*
- [48] Alam E., 2003. Coping with cyclone havoc: an occupational group perspective. *Journal of Asiatic Society of Bangladesh (Humanities)* 48 (2): 59–74.
- [49] Salik K.M., Jahangir S., and ul Hasson S., 2015. Climate change vulnerability and adaptation options for the coastal communities of Pakistan. *Ocean & Coastal Management* 112: 61-73.
- [50] Sreenonchai S. and N. Arunrat. 2019. Fishers' decisions to adopt adaptation strategies and expectations for their children to pursue the same profession in Chumphon Province, Thailand. *Climate* 7(2): 34.
- [51] Vulturius G., André K., Swartling Å.G., Brown C., Rounsevell M.D., and Blanco V., 2018. The relative importance of subjective and structural factors for individual adaptation to climate change by forest owners in Sweden. *Regional Environmental Change* 18(2): 511-520.
- [52] De Coster J., 1998. Overview of factor analysis.
- [53] Benson J. and F. Nasser. 1998. On the use of factor analysis as a research tool. *Journal of Vocational Education Research* 23(1): 13-33.
- [54] Henson R.K. and J.K. Roberts. 2006. Use of exploratory factor analysis in published research: Common errors and some comment on improved practice. *Educational and Psychological measurement* 66(3): 393-416.
- [55] King J.E., 2008. Binary logistic regression. *Best Practices in Quantitative Methods*: 358-384.





## Gender Perspectives of Energy, Disaster Management and Climate Actions in Rural Bangladesh

[www.ericjournal.ait.ac.th](http://www.ericjournal.ait.ac.th)

Anusree Ghosh<sup>\*1</sup> and Tapas Ranjan Chakraborty<sup>+</sup>

**Abstract** – Strong evidences are appearing that show the intensity and frequency of natural disasters are increasing in Bangladesh under the changing climate conditions. These disasters and climate change induced challenges create various forms of challenges in energy sector in terms of availability of energy options, access to energy, increased burden related to costs; and women, especially in the rural contexts, suffer from these challenges the most. In these contexts, this study was conducted with the community located in the Daskhin Kharibari village of Dimla Upazila of Nilphamari district of northern Bangladesh. The field works took place between June 2018 to January 2020 using participatory action research tools to know the gender perspectives of energy, disaster management and climate actions in the rural Bangladesh contexts. The findings of the research show the vulnerability of women as results of the challenges indicated above and their short- and long-term coping strategies to the conditions. It is also suggested how additional support from different sectors may help local adaptation efforts more useful.

**Keywords** – Bangladesh, climate action, disaster management, feminism of agriculture, gender.

### 1. INTRODUCTION

Bangladesh is recognized worldwide as one of the most vulnerable countries due to the impacts of climate change [1]. The country is highly vulnerable to natural disasters because of its geographical location and land features, between the Himalayas and the Bay of Bengal. Climate change accelerated the intensity and frequency of occurrences of salinity, storms, drought, irregular rainfall, high temperature, flash floods, etc. that resulted from global warming. Global warming is harmful for crops of the tropical countries [2]. The charlands of northern Bangladesh are one of the most vulnerable areas of the country. Charlands are the newly formed land on the bank of river and locally termed as riverine islands. The land is not stable and sandy, while the productivity of the land is less. The inhabitants of the charlands are poor. The charlands of the Nilphamari district is vulnerable to flood, extreme heat and extreme cold.

The climate change and disaster risks are impacting women differently. Women generally take the responsibility of agricultural activities because of the migration of the male members of the community for income generation. Women also take the burden to gather fuel wood from the natural environment. The increasing trends of hazards resulted work burden to the women. Literature review indicates that ‘gender differentiated impacts’- are directly related to traditional gender roles of women. It also reveals the constraints to

women’s adaptation resulting from access to resource allocation and other elements of society [3]. As the global community pass through the transitions towards the implementation of the post-2015 development agenda, i.e., the Sustainable Development Goals (SDGs), it is imperative that gender equality and women’s empowerment continue to influence, shape and drive the collective climate and human development efforts [4]. Bangladesh has set National Priority Index (NPI) towards achieving the SDGs and the contribution of women is well noted in the NPI.

To cope up with the climate change, the community is practicing different coping mechanism many of which are supported by different development interventions. However, the objective of the study is to know how the women of the charlands in Bangladesh address the requirement of food, water and energy during the disasters. In patriarchal society those are considered as women’s responsibility. Women as the vulnerable group is considered as target beneficiaries of different development interventions. Such interventions are empowering the women. The current study was conducted in the village of Daskhin Kharibari to know the gender perspective of climate change and disaster management emphasising the energy requirement of a rural community.

### 2. METHODOLOGY

The community particularly women farmers of the village Dashkhin Kharibari were trained on using the participatory action research tools from different development projects. Participatory research methods were geared towards planning and conducting the research process with those people whose life-world and meaningful actions are under study. Consequently, this means that the aim of the inquiry and the research questions develop out of the convergence of two perspectives, that of science and of practice. It is a very

<sup>\*</sup>Hajee Mohammad Danesh Science and Technology University, Dinajpur, Bangladesh.

<sup>+</sup>Oxfam in Bangladesh, Dhaka, Bangladesh.

<sup>1</sup>Corresponding author;

Tel: +8801749044191.

E-mail: [anusreeghosh62@gmail.com](mailto:anusreeghosh62@gmail.com)



demanding process that evolves when two spheres of action- science and practice - meet, interact, and develop an understanding for each other [5]. Participatory research tools are in common use of development studies. Through the participatory research the community themselves can identify the root causes and consequences of the problem in everyday life; they also can identify the required actions of solving the problems.

One hundred women between the ages 20 and 40 were working as research animators of an action research project was implemented in the village Daskhin Kharibari. The research project identified those animators following the socioeconomic state of the village, that is, 20% of them are from extreme poor families, 40% from poor families, 15% from middle income families and 5% from rich families. They know how to conduct Focus Group Discussions (FGDs), transect works, action plan identification and prioritizations of action points, *etc.* To identify gender perspectives on climate change and disaster management there were consultations with them. The selection of the participants of FGDs was random. The village is divided in different clusters, called para. The FGDs were conducted in 4 paras viz., Dighi para, Chairman para, Guideband para, and Camp para. The FGDs were conducted in a common meeting place and 10 to 12 female famers attended for around 2 hours. The discussion in the FGD was spontaneous but was minutely facilitated to remain centered to (a) what are the weather extremities now? Is the vulnerability of women different than men? (b) How women are coping up with the climate challenges? (c) What are the practices and actions taken or followed? Meeting in small group was also conducted with 6 to 7 individuals for around 45 minutes. There were 8 such consultations conducted in different common places like, harvesting ground, water collecting site of the river, tea stalls, *etc.*, to know the efficiency of the information technology use by the women farmers and the gender perspectives of climate change and disaster vulnerability. Total 72 women were consulted in those 4 FGDs and 8 group meetings conducted between June 2018 to January 2020, where 46 women attended in FGDs and rest (28) in group meetings. The age of the women participants of the FGDs and Group meeting was between 20 to 35 years and except 5 of them all were married. Two of them were studying in graduation level, 11 of them have secondary level education, 6 were illiterate and rest other can only read. The discussion was noted detailed and analysed.

Similar participatory method was followed by Sarrica *et al.*, [6] and Khan *et al.* [7] in their studies of gender perspectives of using Information and Communication Technology (ICT) by the rural communities of Bangladesh.

### 3. RESULTS

#### 3.1 Vulnerability of Women from Disaster and Climate Change

In the northern Charland the rainfall pattern has been changed. The intensity and frequency of both the monsoon flood and the flash flood have been increased. The vulnerability of women is different than that of the men during the disasters. The community has identified the vulnerabilities of women due to natural calamities. These are illustrated in the sections below.

#### 3.2 Feminization of Agriculture

Due to increasing natural calamities seasonal migration of the male has been increased. The people of that locality were not migrating to outside earlier but nowadays, the migration rate is too high. Nearly every family has one or two male members working outside the district. It was found that around 40% of the male members of earning age of the village Daskhin Kharibari have migrated to different towns including the capital city. The scope of earning money by working in the locality is not sufficient to meet the needs of the family as expenses to address uncertainty has increased. Such migration has resulted additional responsibility to women for crop framing. The number of women as crop farmer has been increasing dramatically. Now, around 85% women in the village Daskhin Kharibari visited the crop farms year-round. Earlier the presence of women in crop harvesting and preservation was significant, but now it is in every stages of cultivation from seeding to marketing. During 2014-15 to take care of the paddy only a few women were hardly entering up to 1 km inside the field located in the isolated charland; but nowadays, some women of the village visit paddy field located 3 km away from their home regularly. The presence of women in agriculture is mostly as farm labour. The right on decision making on crop selection and marketing by women is very limited. Woman has no ownership and right on the field land.

To cope with the climate change community is practicing new crops. While women are getting gradually the responsibility of farming, they have to manage the new form of cultivation. In the Daskhin Kharibari the paddy is being gradually replaced by the maize. Women are taking more responsibilities of taking care of the maize cultivation and marketing. The harvesting and taking out the seeds from the corn are mostly done by hand. While storing maize takes more places, the common practice is selling the production immediately after harvesting. The profit is going down gradually from the maize.

**Table 1. Impacts of extreme events on women’s daily life.**

Extreme events	State	Impacts on women’s daily life
Flooding	The frequency of the monsoon flood and flash flood has been increased. The duration of inundation has been increased for monsoon flooding.	Women’s workload increased to cope with flood; women have to protect the yard from flooded garbage, specifically the fecal from latrine and cow dung from the cattle shed. Arranging the cooking wood is responsibility of women. The water borne diseases and skin diseases increased during flood and women have to take care of the sick family members. Collecting relief items is also an added activity.
Heavy Rainfall	The rainfall type has been changed; now it is a huge shower in a short time.	Women have to cut drain for water pass from yard and kitchen garden. Keep the fuel wood dry and arrange fuel wood for cooking. Burner drying of cloths also required some time.
Localized Drought	Drought in some small pockets of areas in crop field is very common now.	Hand irrigation is done by women. They collect water from river by pitcher and bucket and walk long to the field for watering. They have to water the kitchen garden and plantation in homestead for the whole winter season as the sandy soil can’t keep the moisture for long.
Extreme heat	Maximum temperature limit is higher	Care work burden of women to sick babies and elderly has increased while heat stroke related sickness increased. Women have to wash more clothes comparing with the regular time. Bathing the cattle, keeping them in shed and give them cut grass and more water are added responsibilities of women in summer.
Extreme cold	Days with extreme cold decreasing but extremity of low temperature increased.	Fever and respiratory problems of family members increase the care work burden of women.
Storm	No changes in frequency or intensity	During the storm women must keep their cattle and poultry in safe places as fast as possible. They took part in protecting houses and crops from strong wind. They took part in reconstruction of the damaged houses. Keeping privacy is a challenge while the boundary fence of house, bathing place and wall of houses got broken due to heavy wind.
Fog	Number of dense hazy days increased	Covering the seedlings of winter vegetables in evening and removing the cover on daytime.
River erosion	Displacement due to river erosion.	Managing food for the displaced family members by any means. Shifting the household assets to other places; Sexual violence while living in a temporary shelter and in new locations.

Source: FGD results.

Because of the cultivation of maize, gender-based violence has increased. The tall plant around the roadside has created a vision barrier. Adolescent girls are victim of teasing and sexual harassment. Child sexual abuse and child rape in the field of maize became a new anxiety.

Though there are more women in crop agriculture there is no progression of promoting gender friendly agricultural tools. Till most of the women farmers in the village Daskhin Kharibari are collecting cereals from the maize crop by hand. There are some corn husking machines run commercially but if the production volume is not enough then it is not profitable both for the farmer and the machine owner. Moreover, male members of the family assumed that women are collecting maize from corn in their free time, so paying money for that is not worthy. If the ‘hand is not busy’ for a woman, most of the male and elderly woman members of the family consider it as ‘woman is staying idle’. Not only the grain collection even for irrigation women are using another

hand as irrigation sprinkler, though there is plastic made water pot available in local market and is not that expensive according to the female farmers. Moreover, the woman farmers have seen the photos of those simple devices in their mobile phone while using Facebook or searching Agro technology. According to the women there are many gender friendly technologies available but as long as the man will not change their mind-set those tools will not come to the female farmer. They also said that no development organization or government intervention has noticed this urgency.

### 3.3 Energy and Water Burden

During disaster, managing fuel is a challenge for women. It is a women’s responsibility to arrange all forms of fuel for the family. The village Daskhin Kharibari has no grid line but while the use of mobile phone has increased a new form of business was developed. There are mobile phone charging shops in the village. The generators are used to charge the mobile

phone in shops. Price of full charging varies from 2 Taka to 5 Taka (0.024 US\$ to 0.059 US\$) for a bottom phone and an android respectively. Major cooking fuel

is the crop residues in the village. The fuel use pattern in regular time and during calamities by the women varies as follows:

**Table 2. Energy use during calamities.**

Source and Task	Source	Use during normal time	Use during calamities
Electricity	No grid, solar panel	Charging mobile phone from the local shops.	Local shops inundated. To charge the mobile phone sets they have to walk around 1.5 km to a highway side market.
Fuel	Wood, dung, crop residues	Mostly they collect wood from dead branches, rarely family is buying wood for cooking. Women collect cow dung and make cakes or coated (jute) stick and sundry. Crop residues dried and piled for use.	Risk of inundation of the stored wood, dung, crop residues, <i>etc.</i> Women took the main responsibility of preserving those.
Sunlight	Sundry	For drying the harvested crops and crop residue.	No place to sun drying during the flood.
Cooking	Woodstoves	Stored wood, dung, crop residues.	Keeping the stored wood, dung, crop residues away from the flood water is responsibility of women.
Lighting	Oil and kerosene lamps	For the study of children and other household works at evening.	Low consumption while purchasing is not easy during flood.
Motive power	Human- and animal powered devices	Ploughing with cow.	Mostly not functioning.

During disasters, collecting water is another burden for women. Women are solely responsible for managing potable water for the family. Only the tube wells in high land are not inundated during the monsoon flood and flash flood. Because only a few tube wells are found with safe water, women have to walk in inundated and muddy path to collect the water. Average water carrying distance in the last flood was three times more comparing with the distance in regular time, and average carrying was 3 buckets full. As the Daskhin Kharibari village was extended centering an embankment, the women living far from the embankment have to take more burden for water collection during flood, they have to use boat and also walk to the tub wells. The mean distance covered was 2.2 km in the last flood of 2018, the time required for them to collect water was 1 hour and 20 minutes in total for both ways. It is good that there no arsenic contamination in this village. Water collection is not only for the family members but for cattle also. If the family has more than two cattles, then only one time collection of potable water is not enough. Many of the female farmers have to collect water for more than 2 times during the early stage of flood in last major flood of 2018.

### 3.4 Coping Strategy

Women's burden is unbearable during the recovery of flood. After flood when the water gets down from the homestead, cleaning is a work burden for the women. The muddy yard must be cleaned. Due to calamities families are also losing their income, specifically those who are wage labours. After every disaster woman has to take a new revised coping strategy. That strategy includes from less eating to new income generation activity.

In the village of Daskhin Kharibari, at the aftermath of the floods, around 75% women have compromised their food intake. To meet the family food crisis many of them have collected leafy vegetables from nature; some have learnt fishing.

The community was found aware about the climate change from various interventions by the development agencies and government initiatives. They have been participating in different gatherings and learnt about the climate change. They themselves classified their coping mechanisms in to the following two categories:

- (1) Spontaneous, and
- (2) Planned

For communities situated in a disaster-prone area, natural calamity is a part of life. They have been

practicing different traditional coping mechanisms. To cope with the flood high raising the plinth is a traditional practice. The female of community was used to keep a handful of rice in a pot while taking rice for boiling, they have been practicing this consistently; which is now in a form of foodbank by the facilitation of different development organizations. Seed preservation was a traditional coping mechanism of preserving the seeds of vegetable and minor crops. Women had been preserving cooking wood and cow dung coated jute stick for use during monsoon. There are portable stoves found to cook during the flooding. Women are taking the lead role in traditional coping mechanisms.

In the village, the community is practicing good number of climate change adaptation practices and using information technology for adaptation knowledge management. Those interventions are facilitated by development organizations Pollisree and Oxfam. There are also few other development interventions from non-government organizations, namely CARE, World Vision and RDRS, etc. Those planned adaptations are being practicing by selected community members who are the beneficiaries of those projects. It was found that some other community members who are not beneficiaries of any project are also practicing those technologies following them. The planned adaptations are mostly those technologies that were being practiced in some other areas and resulted success. Welcoming the new technologies was not always found spontaneous. Some technologies were found good in demonstration only but not in wider practice.

**Table 3: Women in practicing spontaneous adaption to climate change.**

Sl	Practices	Role of women
1	Saving rice from every meal	Put a handful of rice in a pot before boiling
2	Seed preservation	Collect vegetable seeds in bottle and drying as required
3	Storing cooking wood	Store wood or cow dung coated jute stick on ceiling
4	Save money	Women save money to banks and local cooperatives for the hard time

The demonstration cultivation of adaptation in agriculture including field crops and kitchen gardens was done by women in many locations of the village. Cropping in raised plinth, soil tower made of local material like bamboos and poly sheets, cultivating in PET bottles, crop rotation, cultivation of wild vegetables in kitchen gardens, etc., were being demonstrated by the woman farmers.

To cope with climate change, the community now is cultivating different new crops. The promotion of the new crops including new varieties and species was both spontaneously and driven by development interventions of non-government organizations. In the charland the cultivation of paddy is gradually reducing because of the

maize cultivation. The community likes the maize cultivation as it requires less water than the rice cultivation and there is promotion of market value chain by both business community and development community. Pumpkin cultivation in charland is being popularized by non-government organizations, like the Practical Action.

Practicing the planned adaptation technologies in the homestead the community has started cultivating some wild vegetables in their kitchen garden too. Gima shak, *Glinus oppositifolius* (botanical family: Molluginaceae (Carpetweed)) is being cultivated in most of the household at the Daskhin Kharibari village while it is also found in wild.

To meet the cooking wood crisis, the Bandhu Chula and also cement made portable cooker are becoming popular. As the cement made portable cooker is easy to use there are a few entrepreneurship developed for making such cooker.

### 3.4 Role of Awareness, Knowledge and Information in Climate Change and Disaster Management

The new form of agriculture requires new knowledges and new technologies. Moreover, the farmers are new too. Traditional knowledge was not sufficient enough to address the requirements of the new cultivation practices. The transfer of traditional knowledge from generation to generation was found though for the field agriculture but there is a gender gap. Transfer of knowledge of field framing was found mostly from male to male between the generations. The females are aware about it by observing only. As the mobile phone penetration is significantly high now a day, NGOs found the use of mobile phone is worthy for dealing the need of new knowledge. Pollisree and Oxfam in Bangladesh along with Monash University and ICT companies, and local academic partner Hajee Mohammad Danesh Science and Technology University have been implementing the action research project PROTIC at the Dashkhin Kharibari village. PROTIC provided agricultural advisory services to the women farmers by Short Message Services (SMS), outbound dial (OBD) and Call Center. It was found that the use of mobile phone for knowledge management was noteworthy, while the use efficiency and self-efficiency of technology in rural women were quite satisfactory. The agriculture advisory services were mostly on adaptation technologies and varieties that can cope with the local hazards. There was agrometeorological information providing too. By owning the mobile phone the female farmers started using different apps. Apps on weather prediction were found very helpful. For longer preservation of rice, the community boils the rice and then sundry. If it is long rainy days the sun drying will be not be possible or will take more days to dried up, so the woman farmers check the weather prediction and soak their rice. Many of the community members have identified such weather forecasting as a great help for them.



The women farmers as the participants of that action research have learnt the adaptation technologies as well as know the weather prediction and forecasting. They are capacitated with knowledge and are considered as the adaptation knowledge hub of the community. They are demonstrating different adaptation practices, and also creating a climate smart community through their voice and interaction. Though there was no institutional structure formed as a knowledge hub, but the female farmers capacitated from the project helping the community with disaster forecasting and climate adaptive farming technologies. According to the woman farmers of the Daskhin Kharibari village now they are valued in the society.

The female farmers of the village Daskhin Kharibari are well aware about the local administrative process. Their knowledge on the adaptation technology and use of Information Technology is well known to the community and local administration. They are disseminating the climate change adaptation practices and disaster preparedness. They are leading the community with their knowledges and voices. They are also vocal and well aware about the local governance. There are records of influencing the Union Parishad (the lowest administrative unit of the country) in selecting beneficiaries of government safety net coverage. Through the development organizations they are participating in different community gatherings. Two women of that remote village have been awarded as Jayeeta by the Ministry of Women Affairs, Government of Bangladesh; which award is given to women who have created followable example of success in particular areas of life, including entrepreneurship, social development, education, employment, motherhood, and prevention of repression.

#### 4. DISCUSSION

Most of the adverse effects of climate change will be in the form of extreme weather events, while water-related hazards such as flood, drought, salinity increases, bank erosion, and tidal bore are likely to be exacerbated, leading to large scale damages to crop, employment, livelihoods, and national economy [9]. According to Ali *et al.* [10] the Flood Intensity Index will significantly be increased due to climate change. As a floodplain, part of the country becomes inundated in every peak monsoon. For the same hydro-geophysical hazard, however, women face flood differently than males. Among those affected by flood and related problems, women and children are usually the most helpless and disadvantaged [9]. The vulnerability of women and their responses towards climate change and disaster risk reduction are different than that of men. The study found that the work burden has been increased for women. The male migration and new responsibility of women in field farming added the obligation of food security to the women. Food security in developing countries is complex, multifaceted, interlinked and intertwined with different socio-

economic and political aspects [11]. Consequently, women, poor, children and marginalized people suffer extremely in such hostile environmental circumstances and substantiated victims to food insecurity and its ill-effects [12]. Climate related policies and adaptation mechanisms of Bangladesh are not gender neutral yet. Every year various degree of the flood impacting the livelihoods of the charland. As a result of the impact of flood, people suffer more and disrupt their income-generating activities, agriculture, infrastructure, food supply systems, and other parts of the livelihood. The people are passing their entire life while striving against flood in char, and the main interesting matter is that the char dwellers, directly and indirectly, depend on rivers and floods for their livelihood [13]. Lifestyle change is a complementary call for a continuous effort encompassing spread of awareness of sustainable lifestyles, energy concerns, building of synergies between policy, regulation, technology, market forces and ethical imperatives. The focus of change needs to be on patterns of energy consumption [14]. Rural households are the end user of energy and their energy demand includes energy for lighting and cooking. A survey conducted by Halder *et al.* [15] in a nearly similar remote village has identified that, the cooking energy is the dominate energy demand by the households as accounts almost 90% of total demand, on the other hand, lighting energy demand shares only a nominal amount of total demand as estimated about 10%. Most of the households in the study area use agricultural wastes, fuel wood and tree branches and dung for cooking. The disaster situation creates burden to the women while due to inundation a crisis of storage of those cooking fuel happened. Moreover, the indoor cooking also has a risk of health hazard. Modern and clean energy like electricity and efficient cooking technologies in the rural areas in developing world provide improved and healthy lifestyle to help in reducing harmful environmental effects.

Participation rate of women in agriculture in Bangladesh is increasing. Shifa [16] identified that it increased by 136.025% during the period from 1999-2000 to 2016-17. Different literatures on 'Gender in Agriculture' reveal that women lack access to and control over resources such as land and capital as well as agricultural inputs and technology such as improved crop varieties, training information and marketing services [17]. Again, there are also evidences that women have an unmanageable workload, they lack access to credit or have no decision-making power over credit and are poorly represented in agricultural and non-agricultural groups and organizations [18], [19]. Singh and Vinay briefed significance of female labour in agriculture and allied activities. They further stated that the role of women in agriculture as female labour is not highlighted in India. Despite of their presence in activities sowing, transplanting and post-harvest operations they are considered as an invisible worker [20]. The state was found same for Bangladesh too. The

feminization that happened there in agriculture is the presence of more women in crop farming as work force not as decision maker. Despite of various social, economic and various other constraints women have high level participation in agriculture, and they are very committed in their agricultural activity [21].

Land tenure is a challenge. The ownership of the crop lands belongs to male farmers; to obtain banking and other financial facilities woman farmers face many problems. Cultural norms and regulations, religious belief, traditional views, less availability of time as women have to concentrate on household works and different restrictions from family members acts as major constraints for women to participate in agricultural extension education services [22]. It was found that promotion of adaptation knowledge through ICT was helpful for women to overcome the constrain. Becoming economically independent through the help of ICT the rural women also keep a great contribution in the economy of our country [23]. But it is true that contribution of women in agriculture is yet to be broadly recognized. There are huge untapped potentials of using ICTs in climate change adaptation [24], government intervention, development project and private sector may explore those potential for sustainable development of the country. We are towards the middle-income economy, the ICT use will faster the process. Knowledge and information play a key role in overcoming constrains and are pivotal for building and capacity of multiple stakeholders involved in adaptation strategies at the micro, meso and macro level [25].

Although women's social, economic and political position in society makes them more vulnerable to natural hazards, but they are not helpless victims. Women are important agents for change and need to be further strengthened as such. Recognizing and mobilizing their skills and capacities as social force and channeling it to enhance efforts to protect their safety and that of their communities and dependents is a major task in any disaster reduction strategy [26]. The state of vulnerability and capacity along with the scopes and constrains should be considered in implementation of development action. Transformative leadership is a vital towards community resilience. Gender-specific capacities of women deriving from their social roles proved to be beneficial for their whole communities during every stage of the disaster cycle. Women's high level of risk awareness, social networking practices, extensive knowledge of their communities, task in managing natural environmental resources and caring abilities makes of them important players of effective risk assessment, early warning, disaster response and recovery actions [27].

For many women, influence in families and communities, and the ability to make decisions depends on their ability to earn an income. Their income-generating ability allows them mobility, a say in household decisions about expenditure, and clout in communities which allows them to give advice to others,

and ask for help when they need it [28]. Access to sources of income during post-disaster is important in preserving the influence and decision-making ability of women. In the case of lost or unviable livelihoods following disasters, access to training and capacity building, such as advice on improving agricultural practices will be the key for women.

Bangladesh is a good example of disaster management. Soon after the birth of Bangladesh, Father of the Nation Bangabandhu Sheikh Mujibur Rahman established the relief ministry on 12 January 1972 giving a special attention to build a disaster resilient country through minimizing losses of lives and properties caused by different natural events including cyclone and flood. The adverse impacts of all the natural hazards affecting socio-economic condition need to be reduced for sustainable development. Realization of this reality, the Government of Bangladesh has undertaken a lot of plans and programs for disaster reduction through disaster management. The country is striving hard to establish an elaborate and experienced disaster management system from national down to community level to mitigate the effects of disasters. Considering the gender perspective of climate action and disaster risk reduction is essential to every planning and execution. Presence of women in every stage is not only the number of women in the project cycle but the issues of women being addressed through the process.

The aftermath of the COVID-19 pandemic definitely will amplify the trend of male migration from the village Daskhin Kharibari and other remote locations. The agrarian community to face the risk of food insecurity needs to cultivate more. The Honorable Prime Minister Sheikh Hasina urged farmers to keep no land fallow. Whole the major farming responsibility gradually being shouldered by women, all the humanitarian responses and recovery along with development attempts should consider the issues of women farmers with precedence.

## 5. CONCLUSION

Due to the impact of climate change the natural hazards in Bangladesh are increasing and women are becoming more vulnerable. The socio-economic and cultural contexts are major challenges for women to cope with the climate and disaster vulnerabilities. The coping strategies of women both spontaneous and supported are different than that are commonly considered for the community in a gross. Attempts of the government and the development agencies are with wide spectrum, but the context says that the gender perspectives of climate action and disaster risk reduction is not well analyzed in designing, planning and implementing of projects and development actions. Bangabandhu Sheikh Mujibur Rahman's recognition of and contribution to rehabilitation of the rape victims of 1971 war of independence is a real example of giving women the most coveted empowerment, said people from every

walk of life on the eve of the birth centenary of Bangabandhu Sheikh Mujibur Rahman [29]. Bangabandhu was concerned about the women and children. In His birth centenary our development and disaster responses commitment should sworn on 'Nothing about her without she'.

## REFERENCES

- [1] World Bank, 2012. Turn down the heat: why a 4°C warmer world must be avoided. A Report for the World Bank by the Potsdam Institute for Climate Impact Research and Climate Analytics, Washington, DC.
- [2] World Bank., 2010. Bangladesh - Country Assessment Strategy FY 2011-2014. Bangladesh Country Management Unit, South Asia Region, The World Bank Office, Dhaka.
- [3] Tanny N.Z. and M.W Rahman. 2016. Climate Change Vulnerabilities of Woman in Bangladesh. *The Agriculturists* 14(2): 113-123.
- [4] UNDP, 2016. Overview of linkage between Gender and Climate Change, Policy Brief 1. United Nation Development Programme.
- [5] Bergold J. and S. Thomas. 2012. Participatory research methods: A methodological approach in motion. *Forum: Qualitative Social Research* 13 (1): 191-222.
- [6] Sarrica M., Denison T., Stillman L. Chakraborty, T and Auvi P., 2017. "What do others think?" An emic approach to participatory action research in Bangladesh. *AI & Society*. doi: <https://doi.org/10.1007/s00146-017-0765-9>.
- [7] Khan Tithi T., Chakraborty T.R., Akter P., Islam H. and Sabah A.K., 2020. Context, design and conveyance of information: ICT-enabled agricultural information services for rural women in Bangladesh. *AI & Society* (2020). doi: <https://doi.org/10.1007/s00146-020-01016-9>.
- [8] Ghosh M.M. and A. Ghosh, 2014. Analysis of women participation in Indian agriculture. *OSR Journal of Humanities and Social Science (IOSR-JHSS)* 19(5), Ver. IV: 1-6 Association, 35(4), 216-224.
- [9] CCC, 2009. *Climate Change, Gender and Vulnerable Groups in Bangladesh*. Climate Change Cell, DoE, MoEF; Component 4b, CDMP, MoFDM.
- [10] Ali M.S., Mahjabin T. and Hosoda T., 2012. Impact of climate change on floods of Bangladesh and introducing flood intensity index to characterize the flood scenario. In *Proceedings of 1st International Conference on Civils Engineering for Sustainable Development*, 23-24 March 2012, KUET, Khulna, Bangladesh.
- [11] Mirza M.M.Q., 2011. Climate change, flooding in South Asia and implications. *Regional Environmental Change* 11(1): 95-107.
- [12] Uruguchi J.B., 2010. Food price hikes, food security, and gender equality: Assessing the roles and vulnerability of women in households of Bangladesh and Ethiopia. *Gender and Development* 18(3): 491-501.
- [13] Hossain B., Sohel S. and Ryakittimbo C.M., 2020. Climate change induced extreme flood disaster in Bangladesh: Implications on people's livelihoods in the Char Village and their coping mechanisms. *Progress in Disaster Science* 6.
- [14] Roy J. and S. Pal. 2009. Lifestyles and climate change: Link awaiting activation. *Current Opinion in Environmental Sustainability* 1(2): 192-200.
- [15] Halder P.K., Paul N., Arefin S., Rezwan Kabir K.M., and Beg M.R.A., 2015. Diversification of rural energy consumption pattern in Bangladesh: A case study. In *Proceeding of International Conference on Mechanical, Industrial and Materials Engineering 2015 (ICMIME2015)*, 11-13 December 2015, RUET, Rajshahi, Bangladesh.
- [16] Shifa S., 2018. Women in Bangladesh agriculture: Scope, determinants and constraints. Seminar Paper (unpublished). Department of Agricultural Economics. Bangabandhu Sheikh Mujibur Rahman Agricultural University, Salna, Bangladesh .
- [17] Fletschner D. and L. Kanney. 2011. Rural women's access to financial services: Credit, savings and insurance. ESA Working Paper No. 11-07, Food and Agriculture Organization, Rome.
- [18] Alkire S., Meinzen-Dick R., Peterman A., Quisumbing A., Seymour G., and Vaz. A., 2013. The women's empowerment in agriculture index. *World Development* 52: 71-91.
- [19] Akter S., Krupnik T.J., Rossi F., and Khanam F., 2016. The influence of gender and product design of farmers' preference for weather indexed crop insurance. *Global Environment Change* 38: 217-229.
- [20] Singh D. and B. Vinay. 2013. Gender participation in Indian agriculture: An ergonomic evaluation of occupational hazard of farm and allied activities. *International Journal of Agriculture, Environment & Biotechnology* 6 (1): 157-168.
- [21] Samndi D. and M. Yohana. 2007. Women participation in agricultural production- A probit analysis. *Journal of Applied Sciences* 7(3): 412-416.
- [22] Butt T.Z., 2010. Role of rural women in agricultural development and their constraints. *Journal of Agriculture & Social Science* 6: 53-56.
- [23] Roy M., 2013. Pragmatic approaches to sustainable development through rural women empowerment in Bangladesh. *Journal of Economics and Sustainable Development* 4 (10):1-8.
- [24] Imam N., Hossain M.K., and Saha T.R., 2017. Potentials and challenges of using ICT for climate change adaptation: A study of vulnerable community in riverine islands of Bangladesh. In: Kaur H., Lechman E., Marszk A. (eds) *Catalyzing*

- Development through ICT Adoption*. Springer, Cham.
- [25] Ospina A.V. and R. Heeks. 2011. ICTs and climate change adaptation: Enabling innovative strategies brief 1: Climate change, innovation and ICTs project. Centre for Development Information of the University of Manchester, UK.
- [26] Gokhale V., 2008. Role of women in disaster management: An analytical study with reference to Indian society. In *Proceedings of the 14th World Conference on Earthquake Engineering*, October 12-17, 2008, Beijing, China.
- [27] Aguilar L., 2009. How natural disasters affect women. *IUCN*. Retrieved July 22, 2020 from the World Wide Web:<https://www.iucn.org/content/how-natural-disasters-affect-women>.
- [28] UN Women, 2015. *Disaster management in Bangladesh: What women need*. UN Women Bangladesh.
- [29] Mallik B., 2020. *Bangabandhu, the pioneer of women empowerment*. The Daily Observer (a newspaper published from Dhaka), 17 March 2020, Dhaka, Bangladesh







[www.ericjournal.ait.ac.th](http://www.ericjournal.ait.ac.th)

# White Paper

## Top Ten Priorities: in Implementation of Low Carbon Sustainable Energy Development and Adaptation Framework to Reduce Disaster Impact in the Context of Bangladesh

Joyashree Roy\*<sup>+,1</sup>, Sheikh Tawhidul Islam<sup>^</sup>, Indrajit Pal<sup>#</sup>, and Hasan Mahmud<sup>@</sup>

*This white paper recognises that for the decision makers and policy makers implementation of any intervention for changing the existing service delivery model, production model, market or regulatory model that impacts consumers and citizens are the most challenging tasks. Uncertainties about consumers and citizens' responses lead to delays or suboptimality in action. Ten priority actions with major direct SDG links that can reduce uncertainty in decision making in energy, climate change and disaster contexts of Bangladesh are derived from the assessment of research outputs of more than 70 lead subject experts and peer reviewed through blind review process by 50 expert reviewers from all over the world published in two special issue volumes of this Journal and research undertaken under the Bangabandhu Chair endowment at the Asian Institute of Technology, Thailand.*

This white paper provides ten top priority actions for direct and focused solution that are useful for Bangladesh, a country that aims to graduate to developed country status within next two decades passing through middle income stage by 2024. In next two decades global goal is to achieve net zero carbon emission. The priorities for Bangladesh need to integrate local aspiration with global goals. Decisions for most of the actions which will build the roadmap for next two decades should be taken now. Faster transition to deliver wellbeing for the people of Bangladesh can happen only through transformative actions and not just incremental small step actions.

1. **For faster renewable energy penetration** in Bangladesh urgent policy action is needed to overcome the top most barrier of human capacity. Shortage of trained manpower with right skill to assess resource potential, lead and manage innovation, guide technology development and deployment, enterprise development for local manufacturing, can be overcome through introduction of extensive teaching and training programmes within universities and college curriculum and by creating a network of national institutions. Collaboration with international

institutes will expedite the process with very high future dividend. This will accelerate the process of training of national trainers and new skilled manpower and simultaneously satisfy multiple SDGs (SDG 4, SDG12, SDG13, SDG 17, SDG7, SDG 1, SDG2, SDG 6).

2. **Inclusive, transparent single window institutional arrangement** can reduce delay in bureaucratic processes in renewable **energy project** clearance, integration with grid and accelerate investment penetration and social acceptance. Consumer feedback integration with technology innovation, policy innovation and regulatory changes can help reduce transaction cost. Top down target setting and bottom up innovation uptake need to be managed by a special exclusively focused task force which is empowered to go beyond line ministries/departments and act as a “national transitions management” team publicly accountable and monitorable framework. (SDG 12, SDG 13, SDG 16, SDG 10).
3. In **energy sector local innovation, technology** and business model development and communication strategy should get priority to continuously reduce uncertainty about performance of new technology in local context, price volatility, policy shifts, financial resources availability to give confidence to investors and help market mechanism to grow in the long run (SDG 8, SDG 9, SDG7, SDG 10).
4. Currently, **energy related data** are scattered and available from diverse sources e.g., official publications like annual reports, planning documents, national statistical yearbook, news, announcements, project developers. Demand side data from the various sources do not match or are even non-existent. All these are barrier to planning, design new investment as well as monitoring, sometimes leading to costly duplication of efforts. This can be solved by creating dedicated officially endorsed data base of both supply side and demand side and which will help building awareness about low carbon and low energy demand roadmap for Bangladesh (SDG 7, SDG 9, SDG 12, SDG17).

\*Bangabandhu Chair Professor, Sustainable Energy Transitions programme, School of Environment Resources and Development, Asian Institute of Technology, P.O. Box 4, Klong Luang, Pathumthani 12120, Thailand.

<sup>+</sup> Professor of Economics, Jadavpur University, India (on lien).

<sup>^</sup> Professor of Geography and Director, Institute of Remote Sensing, Jahangirnagar University, Bangladesh.

<sup>#</sup> Disaster Preparedness, Mitigation and Management, Asian Institute of Technology, P.O. Box 4, Klong Luang, Pathumthani 12120, Thailand.

<sup>@</sup> Bangabandhu Chair Researcher -Doctoral Level, Sustainable Energy Transition, EECC Department, Asian Institute of Technology, P.O. Box 4, Klong Luang, Pathumthani 12120, Thailand.

<sup>1</sup> E-mail: [joyashree@ait.asia](mailto:joyashree@ait.asia)

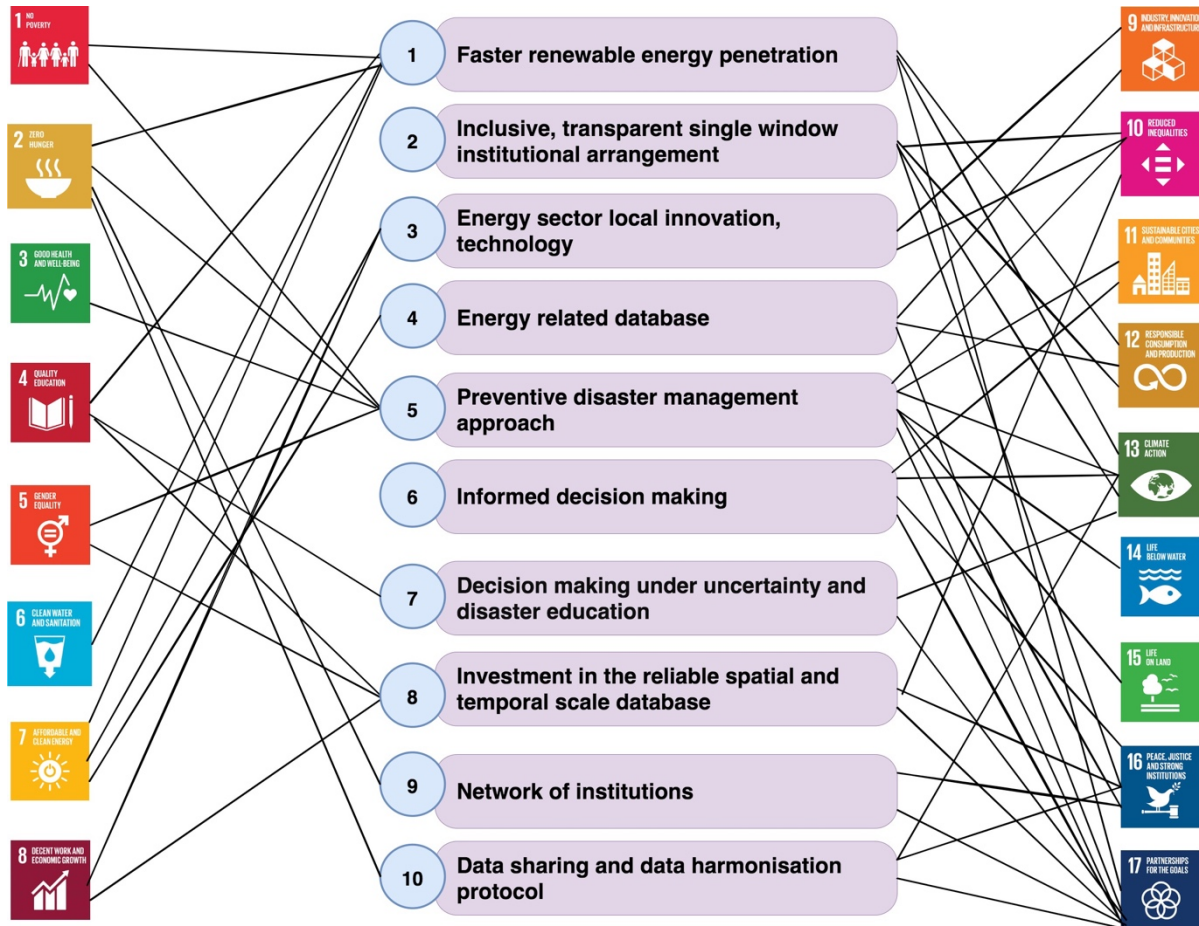

Fig. 1. Top ten priority actions with indicative direct SDG links

5. For a disaster-prone country like Bangladesh **preventive disaster management** approach to reduce exposure of communities should be a priority rather than traditional post disaster relief driven management plans and actions. Multiple hazards need complex system of infrastructures development plans. Community empowerment with special attention to gender and better vertical integration to minimize local level vulnerability is core of transformative adaptive inclusive and transparent governance. Digital mapping of community of risk in various risk categories can be a good starting point (SDG 5, SDG 11, SDG 13, SDG 14, SDG 15, SDG 16, SDG 17, SDG1, SDG2, SDG3, SDG 10)
6. Reduction of loss and damage depend on quality of **informed decision making** for maximizing benefits from ‘response and recovery actions. Sendai Framework for Disaster Risk Reduction (SFDRR) 2015- 2030 for building institutions to support resilient communities with better adaptive capacity will depend on making critical infrastructure network resilient through appropriately trained and empowered community. (SDG 11, SDG 13, SDG 16, SDG 17).
7. Current pool of trained personnel and institutional arrangement good for addressing specific type of disaster need additional knowledge and skill to handle increasingly complex changes. Multiple/cascading disaster driven risk informed policy formulation and actions need special cognitive skills for understanding risks, knowledge, training and technology. **Decision making under uncertainty and disaster education** should form a compulsory study discipline at various levels: schools, colleges, universities and professional training organisations. (SDG 4, SDG 13, SDG 17).
8. To shape the decision making through next two decades under growing uncertainty when Bangladesh aspires to attain developed country status graduating through middle income status **investment in building a nationally rooted reliable spatial and temporal scale data base on digital platform** becomes a prerequisite. Information is the key to develop implementation strategies and dynamic baseline to build an economy to deliver human wellbeing. To decide on actions and responsibilities with continuously changing baseline can be monitored only through access to reliable data base. Current efforts to satisfy global reporting needs are working well but a step jump now is needed for managing the implementation of internal national sustainable developmental actions. Gaps in updated granular data at household and neighbourhood scale on natural capital, social capital, human capital, physical capital and knowledge capital should be started now to help mapping changing baseline involving local academic institutions and youths. (SDG 4, SDG 5, SDG 8, SDG 16, SDG 17, SDG 10).

9. It is right time to start Bangladesh statistical commission which can coordinate and develop protocol for data need, updates, comparison and matching with right group of human capital. E.g., commendable work by National Agricultural Research Systems get undermined when state of the soil data is found to be more than 4 decades old especially when characteristics of hydro-climatologically active floodplains change frequently and link with agricultural trade statistics and implications become important. NARS also has set a good example of interinstitutional coordination structure. Such **network of institutions** under one umbrella of statistical commissions can bring economic, social and environmental sectors and asset types (five mentioned in earlier point) on an appropriately connected database to help in short through long term aspiration management of national growth process. (SDG 16, SDG 17, SDG 2).
10. **Data sharing and data harmonisation protocol** need to exist in keeping with diversity of user group starting from researchers to commercial and international decision makers. Revisiting NSDS National Strategy for Development of Statistics 2013, Statistical Act 2013 can be the starting point. NSDI (National Spatial Data Infrastructure) if properly harmonized with UN-FDES, UN-SEEA, ‘DesInventar’ of UNDRR, DRSF (disaster statistics proposed by UNESCAP), PEI (poverty

environment integration) and trade data can help reduce cost and overlaps inherent in fragmented efforts. (SDG 13, SDG 16, SDG 17, SDG 2)

We are happy to start the year 2021 with publication of Volume 2 of Bangabandhu Chair Special Issue of IEJ as a sequel to Volume-1. We are even happier that it is coinciding with the declaration of Bangladesh Government of extension of ‘Mujib Year’ year of Bangabandhu’s birth centenary. We present in Volume-2 concrete action points to accelerate the implementation of the dream of building a Golden Bengal “*Sonar Bangla*”, a concept resembles very closely the long-term Sustainable Development pathway for humanity as a whole.

## REFERENCES

- [1] Roy J., Islam S.T., and Pal I., 2020. Energy, disaster, climate change: Sustainability and just transitions in Bangladesh. *International Energy Journal* 20 (2020) (Special Issue 3A) <http://www.ericjournal.ait.ac.th/index.php/eric/issue/view/Volume%2020%2C%20Special%20Issue%203A%2C%20October%202020>.
- [2] Roy J., Islam S.T., and Pal I., 2021. Energy, disaster, climate change: Sustainability and just transitions in Bangladesh. *International Energy Journal* 21 (2021) (Special Issue 1A).
- [3] <https://www.change framing.space/>.

### **To Quote Bangabandhu Sheikh Mujibur Rahman:**

*“I do not say anything to intellectuals. I respect them. I would only say this to them that, please use your intellects for the welfare of the people. I do not say anything more than this”.*  
(The last public address at Suhrawardy Uddan, 26 March 1975)

*“My greatest strength is the love for my people, my greatest weakness is that I love them too much.”*  
{from : <https://quotes.yourdictionary.com/author/sheikh-mujibur-rahman/>}

*“It is not possible to build golden Bengal without golden people”*  
(The last public address at Suhrawardy Uddan, 26 March 1975)

*“As a man, what concerns mankind concerns me”.*  
(Unfinished Memoirs, 3 May 1973)

*“We can suffer but we don’t die. People’s strength is the biggest force for the challenge of survival. Our aim is to achieve self-dependence”*  
(Addressing the United Nations, 23 September 1974)

*“The world is divided into two halves, the oppressed and the oppressors. I am with the oppressed”.*  
(At the conference of Non-Alliance Movement, Algiers, 6 September 1973)

{from: <https://www.7thmarch.com/quotations/>}





# INTERNATIONAL ENERGY JOURNAL

---

## REGIONAL ENERGY RESOURCES INFORMATION CENTER

The Regional Energy Resources Information Center (RERIC) was established in 1978 as a result of recommendations made at various meetings held in Asia, and particularly those made at a meeting of experts in solar and wind energy utilization held in 1976 under the energy program of the United Nations Economic and Social Commission for Asia and the Pacific (ESCAP).

RERIC collects, repackages, and disseminates information on energy and environmental issues related to energy. The Center's wide range of activities include publishing, networking, consulting and other information services for energy conservation and renewable energy promotion.

The current RERIC staff are as follows:

*Director:*

Dr. Jai Govind Singh

*Editor, International Energy Journal:*

Prof. Sivanappan Kumar

*Research/Information Professional:*

Ms. Maria Kathrina B. Grauto

*Secretary:*

Ms. Phornsinee Thanara

### An All-Inclusive Service for RERIC Members

RERIC members receive the following regular RERIC publications: *International Energy Journal* (formerly *RERIC International Energy Journal*) (4 issues per year).

RERIC members can access online the RERIC bibliographic database and other project databases for information on energy and energy-related environmental issues, receive printout of up to 150 records per year on selected topics and receive discount on publications and services.

RERIC annual membership fees for 2021:

*For USA, Canada, Europe, Australia, New Zealand, Japan and Middle East - Individual:* US\$ 150; **Institutions:** US\$295. *For all other countries - Individual:* US\$ 100; **Institutions:** US\$ 180. The annual membership fee is inclusive of packing and document delivery service (air mailing).

Payment can be processed through credit cards by filling-up the **membership application form**. Cheques or money orders should be made payable to **Asian Institute of Technology**, and sent to the Energy Field of Study/RERIC, Asian Institute of Technology, P.O. Box 4, Klong Luang, Pathumthani 12120, THAILAND.



# INTERNATIONAL ENERGY JOURNAL

The *International Energy Journal*, formerly *RERIC International Energy Journal* is published since 1979. It is a journal dedicated to the advancement of knowledge in energy through vigorous examination and analysis of theories and good practices, and by encouraging innovations needed to establish a successful approach to solve identified energy-related problems. *IEJ* is a quarterly journal that publishes peer-reviewed papers on technical, socio-economic and environmental aspects of energy planning, energy conservation, renewable sources of energy, and electric power transmission, generation and management. The papers are reviewed by renowned referees. *IEJ* also maintains an online journal system wherein not only current volumes are available but also archives containing past volumes and past special issues.

Those wishing to submit article, communications, viewpoints and reviews should consult the Note for Authors on the inside back cover, before sending 3 copies and a soft copy contained in a CD-ROM which could be sent to the Editor, *International Energy Journal (IEJ)*, Regional Energy Resources Information Center (RERIC), Energy Field of Study, SERD, Asian Institute of Technology, P.O. Box 4, Klong Luang, Pathumthani, 12120 Thailand. Submission can also be made through the online journal system at [www.rericjournal.ait.ac.th](http://www.rericjournal.ait.ac.th) or by sending it as an e-mail attachment to [reicjournal@ait.ac.th](mailto:reicjournal@ait.ac.th).

**Editor:** Prof. Sivanappan Kumar

**Associate Editor:** Dr. Pakkeerthamby Abdul Salam

**Assistant Editor:** Maria Kathrina B. Gratuito

## EDITORIAL ADVISORY BOARD

**Professor Saifur Rahman**

Virginia Polytechnic Institute and State University, Virginia, USA

**Professor Ferdinand E. Banks**

Uppsala University, Uppsala, SWEDEN

**Professor W.W.S. Charters**

University of Melbourne, Victoria, AUSTRALIA

**Professor Harry Clarke**

La Trobe University, Victoria, AUSTRALIA

**Professor Ogunlade R. Davidon**

University of Sierra Leone, Freetown, SIERRA LEONE

**Professor R.H.B. Exell**

King Mongkut's University of Technology Thonburi, Bangkok, THAILAND

**Professor Martin A. Green**

University of New South Wales, Sydney, AUSTRALIA

**Dr. Kejun Jiang**

Energy Research Institute, Beijing, CHINA

**Professor Shinsuke Kato**

Institute of Industrial Science, University of Tokyo, Tokyo, JAPAN

**Professor D.P. Kothari**

Vellore Institute of Technology University, Tamilnadu, INDIA

**Professor Hoesung Lee**

Keimyung University, Daegu, SOUTH KOREA

**Dr. Erik Lysen**

Utrecht University, Utrecht, THE NETHERLANDS

**Professor Saeid Mokhatab**

University of Wyoming, Wyoming, USA

**Professor Tapan Kumar Saha**

University of Queensland, Brisbane, AUSTRALIA

**Professor P. R. Shukla**

Indian Institute of Management, Ahmedabad, INDIA

**Professor Somchart Soponronnarit**

King Mongkut's University of Technology Thonburi, Bangkok, THAILAND

**Dr. Leena Srivastava**

The Energy and Resources Institute (TERI), New Delhi, INDIA

**Dr. S.V. Szokolay**

The University of Queensland, Brisbane, AUSTRALIA

**Dr. Govinda R. Timilsina**

The World Bank, Washington, District of Columbia, USA

**Published by the**

**Regional Energy Resources Information Center (RERIC)  
Asian Institute of Technology (AIT)  
P.O. Box 4, Klong Luang  
Pathumthani 12120, Thailand  
Tel: (66-2) 524-5413 or 524-6216; Fax: (66-2) 524-5439  
E-mail: [रिकजर्नल@ait.ac.th](mailto:रिकजर्नल@ait.ac.th)  
Journal homepage: [www.रिकजर्नल.ait.ac.th](http://www.रिकजर्नल.ait.ac.th)**